



# Standard Test Method for Cyclic Pressure Strength of Reinforced, Thermosetting Plastic Pipe<sup>1</sup>

This standard is issued under the fixed designation D 2143; the number immediately following the designation indicates the year of original adoption or, in the case of revision, the year of last revision. A number in parentheses indicates the year of last reapproval. A superscript epsilon ( $\epsilon$ ) indicates an editorial change since the last revision or reapproval.

## 1. Scope

1.1 This test method covers the determination of the failure characteristics of reinforced plastic pipe when subjected to cyclic internal hydraulic pressure. It is limited to pipe in which the ratio of outside diameter to wall thickness is 10:1 or more.

1.2 The values stated in inch-pound units are to be regarded as the standard. The values in parentheses are for information only.

1.3 *This standard does not purport to address all of the safety concerns, if any, associated with its use. It is the responsibility of the user of this standard to establish appropriate safety and health practices and determine the applicability of regulatory limitations prior to use.*

NOTE 1—There is no similar or equivalent ISO standard.

## 2. Referenced Documents

### 2.1 ASTM Standards:

D 618 Practice for Conditioning Plastics and Electrical Insulating Materials for Testing<sup>2</sup>

D 2992 Practice for Obtaining Hydrostatic or Pressure Design Basis for “Fiberglass” (Glass-Fiber-Reinforced Thermosetting-Resin) Pipe and Fittings<sup>3</sup>

D 3567 Practice for Determining Dimensions of “Fiberglass” (Glass-Fiber-Reinforced Thermosetting-Resin) Pipe and Fittings<sup>3</sup>

## 3. Terminology

### 3.1 Definitions of Terms Specific to This Standard:

3.1.1 *failure*—the transmission of the test fluid through the pipe wall in any manner, whether it be wall fracture, localized leaking, or weeping at a distance greater than one diameter from the end closure (specimens failing within one diameter of the end closure shall be discarded).

3.1.2 *failure detector*—a device that measures the electrical resistance between the test fluid and a conductive material, wrapped around the circumference of the test specimen, and which will indicate failure when 1) the resistance is lowered to a range from 10 to 20 meg-ohm or 2) for the case of municipal water, when the first drop of fluid has passed through the wall of the specimen.

3.1.3 *localized leaking*—failure that occurs as small fractures (one or more in a test specimen) that permit the test fluid to be transferred at a rate that is measured by the failure detector.

3.1.4 *weeping*—a general transmission of the test fluid through the pipe, without visible fracture, at a sufficient rate to be measured by the failure detector, or in the case of larger magnitudes of fluid transmission appear to be moisture condensation on the specimen.

3.1.5 *wall fracture*—failure by a break in the pipe wall causing immediate loss of test fluid and continued loss at essentially no pressure.

## 4. Summary of Test Method

4.1 This test method consists of exposing pipe specimens to cyclic internal pressures at several different pressure levels and measuring the cycles to failure at these different levels. Test temperatures are obtained by circulating salt water or municipal water through the specimens.

## 5. Significance and Use

5.1 The values obtained by this test method are applicable only to conditions that specifically duplicate the procedures used.

5.2 After the regression characteristics of a pipe material and manufacturing process have been determined by this test method, one pressure may be used for quality-control purposes. This pressure shall be one of the points used in the original determination and be agreed upon between the individuals concerned.

5.3 This test method deals with cyclic internal pressure performance of a pipe and omits creep and nonrecoverable deformation measurements.

5.4 For determination of the cyclic hydrostatic design basis using data from this test method see Practice D 2992.

<sup>1</sup> This test method is under the jurisdiction of ASTM Committee D20 on Plastics and is the direct responsibility of Subcommittee D20.23 on Reinforced Plastic Piping Systems.

Current edition approved Nov. 10, 2000. Published February 2001. Originally published as D 2143 – 63. Last previous edition D 2143 – 94.

<sup>2</sup> *Annual Book of ASTM Standards*, Vol 08.01.

<sup>3</sup> *Annual Book of ASTM Standards*, Vol 08.04.

5.5 In the application of the following test requirements and recommendations it is assumed that test specimens of a given sample of pipe are truly representative of that material and manufacturing process. In tests conducted to show the effect of temperature and pressures on the life span of the pipe, great care must be taken to ensure that the specimens being tested are representative of the group being studied. Departure from this assumption could introduce discrepancies that are greater than those introduced by departure from the details of the procedure outlined in this test method.

**6. Apparatus**

6.1 A schematic diagram of the apparatus is shown in Fig. 1 and shall consist of the following:

6.1.1 *Pressurizing System*—A device capable of exerting cyclic internal pressure of the salt water or municipal water to the test specimens. Fig. 1 shows an oil pump leading to a four-way solenoid-operated valve which directs the fluid alternately to the two pressure legs, each of which contains a spring-operated, manually adjustable, pressure relief valve and an accumulator which acts as a fluid separator transferring the pressurizing medium to the salt solution. The solenoid is operated with equal on and off times by an electric pulsator.

6.1.2 *Test Fluid*—The test fluid shall be a 2 % aqueous sodium chloride solution when salt water or municipal water is used.

6.1.3 *Temperature Bath*—A thermostatically controlled bath coupled into the test fluid, which maintains specimen temperature to within  $\pm 5^{\circ}\text{F}$  ( $\pm 2^{\circ}\text{C}$ ). The circulation of this fluid is pumped on the off portion of the pressure cycle.

6.1.4 *Pressure Gages*—Pressure gages having a precision of not less than 1 % of full-scale deflection with a maximum indicating hand. The pressure gage shall be selected such that the final readings are in the mid-60 % range of the scale. The gage should be equipped with a surge protection device.

6.1.5 *Specimen Fittings*—Any suitable closure that allows free end mounting, and does not contribute to end failures may be used.

6.1.6 *Specimen Support*—Any support is acceptable as long as it does not contribute to the restraint of the specimen in either the circumferential or axial direction.

6.1.7 *Cycle Counter and Failure Detector*— Each group of specimens shall be outfitted with a cyclic counter and a failure detector which automatically stops the cyclic count when the specimen has failed.

**7. Test Specimens**

7.1 *Sample Size*—See Practice D 2992.

7.2 *Specimen Size*—The inside and outside diameters of the specimen shall be as fabricated, with the specimen length between the end closures being a minimum of ten times the outside diameter of the pipe.

7.3 *Measurement of Dimensions*—The physical dimensions of the pipe shall be measured in accordance with Practice D 3567.

**8. Conditioning**

8.1 Precondition all specimens in the standard laboratory atmosphere as specified in Practice D 618.

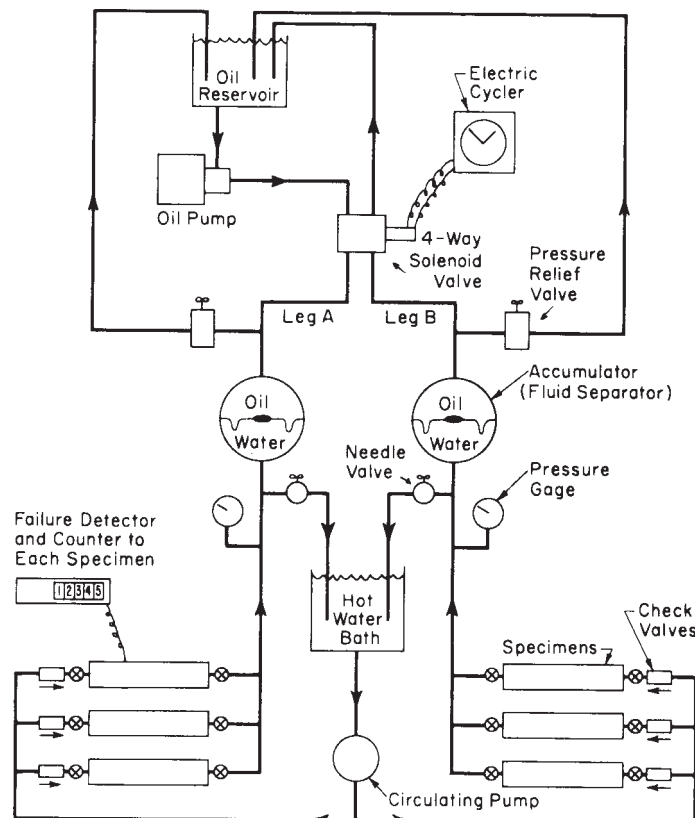

FIG. 1 Schematic Drawing of Cyclic Pressure Apparatus

8.2 The specimen shall be suitable for test when the temperature of the test fluid, at both inlet and outlet, is maintained within 5°F (2.8°C) of the test temperature for a period of 1 h.

8.3 Ambient temperature need not be controlled.

## 9. Procedure

9.1 Attach the specimen with end closures into the system, being careful to eliminate all air from the entire system.

9.2 With the valves to the specimens closed and the power pump operating, adjust the pressure regulator to the desired pressure.

9.3 Open the bypass needle valves, and with the circulating pump running, circulate the salt solution through the specimen to obtain the desired test temperature for conditioning.

9.4 Close the bypass needle valve to permit only enough test fluid to pass through to maintain the test temperature. Connect the failure detector units, reset these units to zero, and start the main power pump.

9.5 Adjust the cycling rate to at least  $25 \pm 2$  cycles/min.

9.6 As additional specimens are added or removed from the system, maintain the maximum pressure condition desired by readjusting the cyclic rate to at least  $25 \pm 2$  cycles/min.

9.7 After each specimen fails, record the failure count as indicated by the failure detector.

## 10. Calculation

10.1 Calculate the hoop stress in the pipe specimen as follows:

$$S = P(D - t)/2t$$

where:

$S$  = hoop stress, psi (MPa),

$P$  = internal pressure, psi (MPa),

$D$  = average outside diameter, in. (mm), and

$t$  = minimum wall thickness, in. (mm).

10.2 For the statistical calculation method, see Practice D 2992.

## 11. Report

11.1 Report the following information:

11.1.1 Complete identification of specimens, including material type, source, manufacturer's name and code number, and previous history,

11.1.2 Pipe dimensions,

11.1.3 Test temperature and test fluid,

11.1.4 Cyclic rate and cycles to failure of each specimen tested and nature of the failure,

11.1.5 Correlation coefficient,

11.1.6 Any unusual effects or observations during or prior to the test,

11.1.7 Dates of test.

## 12. Precision and Bias

12.1 No precision and bias statement can be made for this test method since a controlled round-robin test program has not been run. A controlled round-robin program is not considered feasible due to the number of samples, the duration of time, and the cyclic pressure apparatus specified by this test method.

## 13. Keywords

13.1 fiberglass pipe; hydrostatic design basis; pressure design basis; cyclic pressure strength

## SUMMARY OF CHANGES

Committee D20 has identified the location of selected changes to this standard since the last issue D 2143-94 that may impact the use of this standard.

(1) Sections 4.2 and 11 on plotting data were removed. The user is referred to D 2992.

(2) A keywords and ISO equivalency statement were added.

*The American Society for Testing and Materials takes no position respecting the validity of any patent rights asserted in connection with any item mentioned in this standard. Users of this standard are expressly advised that determination of the validity of any such patent rights, and the risk of infringement of such rights, are entirely their own responsibility.*

*This standard is subject to revision at any time by the responsible technical committee and must be reviewed every five years and if not revised, either reapproved or withdrawn. Your comments are invited either for revision of this standard or for additional standards and should be addressed to ASTM Headquarters. Your comments will receive careful consideration at a meeting of the responsible technical committee, which you may attend. If you feel that your comments have not received a fair hearing you should make your views known to the ASTM Committee on Standards, at the address shown below.*

*This standard is copyrighted by ASTM, 100 Barr Harbor Drive, PO Box C700, West Conshohocken, PA 19428-2959, United States. Individual reprints (single or multiple copies) of this standard may be obtained by contacting ASTM at the above address or at 610-832-9585 (phone), 610-832-9555 (fax), or service@astm.org (e-mail); or through the ASTM website (www.astm.org).*