

DNV Standards
DNV-OS-J102 (New)

PROPOSAL
No.: RP-2005-33 Rev.1
Date: 2006-06-30
Dept.: ZWTDK630
Ref. Sign.: SVJ/JJWH

CONFIDENTIAL
Not for external distribution
without permission

DESIGN AND MANUFACTURE OF WIND TURBINE BLADES

Motives

Reason for proposal

With this proposal for Standard (DNV-OS-J102) DNV defines and documents expectations with respect to the design and manufacturing of wind turbine blades, expectations which currently are already practised in type certification of wind turbine blades. At present, however, no international standard covers all or fully these expectations, although GL have a certification standard for wind turbine blades with a more limited extent.

The primary purpose is to define the basis for type certification of wind turbine blades according to the industry standards IEC WT01 and IEC 61400-1.

This standard is complementary to the existing DNV-OS-J101 "Design of Offshore Wind Turbine Structures".

Scope of the proposal

This standard provides the principles, technical requirements and gives guidance for the design and manufacture of wind turbine blades. The objectives of this standard are to provide:

- A standard for the design and manufacturing requirements for wind turbine blades subject to DNV certification.
- A guideline for designers, manufacturers, operators, and regulators of wind turbines.
- A technical and contractual reference document between clients, contractors, suppliers, consultants and third parties relating to the design, and manufacture of wind turbine blades.

Main contents

- Detailed interpretation of the IEC WT 01 aiding type certification of wind turbine blades.
- Supplementary interpretation of ISO 9000 for certification of quality management systems for the design and manufacturing of wind turbine blades.
- Supplementary standard for Manufacturer Product Quality Assessment (MPQA) services.
- Supplementary interpretation of ISO 17025 for certification of blade test laboratories.
- Detailed standard for third party blade manufacturing inspection.

The proposed standard **does not** cover details for the determination of characteristic loads for wind turbine blades. The intended safety level will be achieved when design loads are calculated on the basis of characteristic loads and partial safety factors as specified in IEC 61400-1.

Planned date of publication: *October 2006*
Planned entering into force date: *As from date of publication*

PROPOSAL

RP-2005-33 Rev.1

The proposed DNV-OS-J102 “Design and Manufacture of Wind Turbine Blades” is an all new standard.

The working title for this type of new document - with Technology Services and parts of Certification merged and renamed DNV Energy is: DNV Standards.

The text is presented in two columns rather than regular full-page width text for reason of keeping the correct positioning of illustrations as placed in the draft. A preliminary List of Contents is included for gaining overview of topics covered by the proposal. Final list will be generated at the time of publication.

TABLE OF CONTENTS

TABLE OF CONTENTS..... 3

LIST OF FIGURES..... 4

LIST OF TABLES..... 4

SECTION 1 INTRODUCTION 5

 A. OBJECTIVES..... 5

 A100 Objectives..... 5

 B. APPLICATION 5

 B100 Application..... 5

 C. NORMATIVE REFERENCES 7

 C100 DNV Standards 7

 201 *The principal methodology in the present standard represents design and testing practice applied in the wind turbine industry. For design of composite components for offshore installations DNV have issued another standard DNV OS-C501 which is based on a different methodology.*..... 7

 C200 IEC Type certification standards 7

 D. INFORMATIVE REFERENCES 7

 D100 General 7

 E. DEFINITIONS 8

 E100 Verbal forms 8

 E200 Terms 8

 F. ABBREVIATIONS AND SYMBOLS 12

 F100 Abbreviations 12

 F200 Symbols 12

 F300 Composite coordinate system..... 13

SECTION 2 MATERIAL QUALIFICATION..... 14

 A. GENERAL..... 14

 A 100 General..... 14

 A200 Characteristic Material Properties..... 14

 A300 Quality system requirements..... 15

 B. FRP MATERIALS..... 15

 B100 General..... 15

 B200 Coupon level ultimate strength qualification..... 16

 B300 Coupon level S-N curve development 17

 B400 Element level qualification..... 18

 B500 Detail level qualification..... 18

 B600 Full scale test..... 18

 B700 Qualification of substitute materials..... 18

 C. SANDWICH CORE MATERIALS 19

 C100 Sandwich core materials..... 19

 D. ADHESIVES..... 19

 D100 Paste Adhesives..... 19

 D200 Adhesive durability considerations 19

 E. LAMINATED WOOD..... 19

 E100 Laminated Wood..... 19

 F. SURFACE FINISHING 20

 F100 Fillers..... 20

 F200 Paints and Gel coats 20

 F300 Paint Application 20

 G. METALLIC MATERIALS 21

 G100 Metallic materials for bushings etc..... 21

SECTION 3 DESIGN ANALYSIS..... 22

 A. GENERAL 22

 A100 Objective 22

 A200 Quality system requirements 22

 A300 Processes 22

 A400 Composite failure modes..... 24

 A500 Design criteria 25

 A600 Partial safety factors for loads (γ_f)..... 25

 A700 Partial safety factors for consequence of failure (γ_n) 26

 A800 Partial safety factors for materials (γ_m) 26

 A900 Geometrical Parameters 27

 B. VERIFICATION OF INPUT FOR DESIGN LOADS AND TOWER CLEARANCE ANALYSIS..... 28

 B100 General 28

 C. TOWER CLEARANCE 28

 C100 General 28

 D. ADDITIONAL FAILURE MODES 28

 D100 Erosion..... 28

 D200 Environmental Protection 28

 D300 Lightning..... 29

 D400 Impact damage..... 29

 D500 Creep..... 29

 D600 Extreme temperatures in the blade 29

 D700 Substantiation of Repair..... 30

SECTION 4 BLADE MANUFACTURING PROCEDURES..... 31

 A. GENERAL 31

 A100 Manufacturing procedure manuals..... 31

SECTION 5 BLADE TESTING..... 33

 A. GENERAL 33

 A100 General 33

 B. SELECTION OF TEST BLADE AND SPECIFICATION OF TESTING 33

 B100 Selection of test blade 33

 B200 Parts of the blade to be tested..... 34

 B300 Natural frequencies and damping determination 34

 B400 Static testing..... 34

 B500 Fatigue testing 35

 B600 Final static testing..... 37

 B700 Other tests 37

 C. QUALITY MANAGEMENT OF TESTING..... 37

 C100 General 37

 D. REPORTING 38

 D100 General 38

SECTION 6 DOCUMENTATION REQUIREMENTS..... 39

 A. GENERAL 39

 A100 General 39

 A200 Design Documents 39

 A300 Technical Documents 39

 A400 Work Instructions and Drawings 39

 A500 Test Documents 39

 A600 Installation and Service Documents..... 40

SECTION 7 BLADE MANUFACTURE 41

 A. GENERAL 41

 A100 General 41

PROPOSAL

RP-2005-33 Rev.1

APPENDIX A – SIMPLIFIED LINEAR ANALYSIS MODELS (INFORMATIVE) 42

A100 General 42

APPENDIX B – FINITE ELEMENT ANALYSIS (INFORMATIVE) 43

A100 Modelling of Structures – General 43

A200 Software Requirements 44

A300 Execution of Analysis 45

A400 Evaluation of Results 45

A500 Validation and Verification 45

APPENDIX C – BUCKLING ANALYSIS (INFORMATIVE) 46

A100 Concepts and Definitions 46

A200 General 46

A300 Calculation of Buckling Resistance 46

A400 Buckling analysis of individual components 48

A500 Buckling analysis of more complex elements or entire structures 48

APPENDIX D – FIBRE FAILURE ANALYSIS (INFORMATIVE) 49

A100 General 49

A200 Maximum strain criterion 49

A300 Tsai-Hill criterion 49

A400 Modified Tsai-Wu criterion 50

A500 Special considerations for in-plane compressive loads 50

A600 Fracture mechanics approach 50

APPENDIX E – MATRIX FAILURE ANALYSIS (INFORMATIVE) 51

A100 General 51

A200 Maximum stress criterion 51

A300 Puck's criterion 51

A400 In-plane shear failure 52

A500 Von Mises yield criterion 53

APPENDIX F – INTER-LAMINAR FAILURE ANALYSIS (INFORMATIVE) 54

A100 General 54

A200 Onset of de-lamination 54

A300 Delamination growth 54

APPENDIX G – SANDWICH FAILURE ANALYSIS (INFORMATIVE) 55

A100 General 55

A200 Typical sandwich failure mechanisms 55

A300 Sandwich core ultimate failure 55

A400 Sandwich core yielding 56

A500 Sandwich Interface 56

A600 Sandwich structure buckling 56

APPENDIX H – FATIGUE LIMIT STATE ANALYSIS (INFORMATIVE) 57

A100 General 57

A200 Cyclic Fatigue 57

A300 Fibre failure in fatigue 58

A400 Change of elastic properties 58

A500 Initiation of fatigue damage 58

A600 Growth of fatigue damage 59

APPENDIX I – IMPACT DAMAGE (INFORMATIVE) 61

A100 General 61

A200 Detailed Considerations 61

LIST OF FIGURES

Figure 1 - Wind turbine design and development processes	6
Figure 2 - Composite coordinate system	13
Figure 3- The Building Block Approach	15
Figure 4 - Typical R-ratios	18
Figure 5- Processes in the analytical verification of wind turbine blade strength	23
Figure 6 - Typical stress-strain relation for a laminate containing 0, 45 and 90 layers	49
Figure 7- Inter-laminar failure modes	54
Figure 8 - Typical sandwich structure failure modes	55
Figure 9- Tabular representation of fatigue loads	57
Figure 10 - Matrix representation of fatigue loads	57
Figure 11 - A typical Constant Lifetime Diagram diagram.	59

LIST OF TABLES

Table 1 - DNV Offshore Service Specifications, Standards and Rules
Table 2 - IEC Type Certification Standards
Table 3 - DNV Guidelines for wind turbines
Table 4 - Other relevant references
Table 5 – Determination of k_m for a 5 th percentile lower limit with 95% confidence for normally distributed population
Table 6 - Uncured constituent testing
Table 7 - Cured lamina/laminate testing
Table 8 - lamina/laminate mechanical property testing
Table 9 - laminate fatigue strength testing
Table 10 - Recommended adhesive strength characterisation tests
Table 11 – Typical composite failure mechanisms
Table 12 - Load factors (γ_f)
Table 13 – Partial safety factors for consequence of failure (γ_n)
Table 14 - Partial safety factors for materials (γ_m) for FRP, laminated wood, and adhesives
Table 15 - Critical blade manufacturing processes
Table 16 - Static test assessment criteria
Table 17 - Fatigue test assessment criteria

SECTION 1 INTRODUCTION

A. Objectives

A100 Objectives

101 This standard provides principles, technical requirements and guidance for the design and manufacture of wind turbine blades. The objectives of this standard are to provide:

- The design and manufacturing requirements for wind turbine blades subject to DNV certification.
- A guideline for designers, manufacturers, operators, and regulators of wind turbines.
- A technical and contractual reference document between clients, contractors, suppliers, consultants and third parties relating to the design, and manufacture of wind turbine blades.
- Detailed interpretation of IEC WT 01 to aid in the type certification of wind turbine blades.
- Supplementary interpretation of ISO 9000 for certification of quality management systems for the design and manufacturing of wind turbine blades.
- Supplementary standard for Manufacturer Product Quality Assessment (MPQA) services.
- Supplementary interpretation of ISO 17025 for certification of blade test laboratories.
- Detailed standard for third party blade manufacturing inspection.

Guidance note:

The type certification of blades according to IEC WT 01 involves design evaluation (verification of material qualification, design calculation and work instructions), manufacturing evaluation (inspection of the manufacturing of one blade) and testing of blades.

The IEC WT 01 design evaluation will both cover the generic and specific elements of the design documentation. Verification of the generic elements will only be carried out in details if these elements are critical for the specific design.

The IEC WT 01 blade testing evaluation is normally carried out as a review of test report from an accredited laboratory and a report for manufacturing of the test blade.

The IEC WT 01 manufacturing evaluation is normally carried out only once. The evaluation is carried out when the manufacturer consider tools (moulds) and quality procedures ready for serial production. Often the quality procedures are in development during the manufacturing of the prototype test blade(s). In such cases the manufacturing evaluation is carried out at a later stage and the documentation for manufacturing of the test blades is reviewed in the light of the final tools.

If design, materials or manufacturing procedures are changed necessary elements of design verification, testing and manufacturing evaluation must be repeated before the IEC type certificate can be reissued.

---e-n-d---o-f---G-u-i-d-a-n-c-e---n-o-t-e---

102 This standard does not cover details for the determination of characteristic loads for wind turbine blades.

The safety philosophy of the blade should be viewed in context with the entire turbine, and it's related criticality. Therefore, the intended safety level for the turbine will be achieved when design loads are calculated on the basis of

characteristic loads and partial safety factors as specified in IEC 61400-1.

B. Application

B100 Application

101 Manufacturing and design of wind turbine blades is normally carried out in both generic and specific levels by the manufacturer. The generic level involves the qualification of design procedures, materials, manufacturing and test methods. The specific level involves design, manufacture and test of individual blade types.

102 The wind turbine blade manufacturer shall establish and control general design procedures, qualification of materials, manufacturing procedures and applicable test procedures through their quality system, e.g., through revision-controlled documentation. Such documentation is to be self-contained and preferably provide the relevant justification for procedures and qualification.

103 This standard is divided into both a generic part concerning documentation of the qualification process, and a specific part concerning blade design and manufacture.

104 Type certification of wind turbine blades can be carried out in three steps as illustrated in Figure 1:

- The first step covers verification of the blade manufacturer's procedural manuals for control of design calculations, materials qualification, manufacturing and blade testing. The verification is carried out on a generic level.
- The second step involves approval of the specific design which is carried out according to the procedure manuals verified in the first step and documented in terms of design drawings, work instructions, design reports and test reports.
- The third step consists of inspection of manufacturing of individual blades according to the design drawings and work instructions verified in the second step. The procedural manuals verified in the first step are used as guidance for this inspection.

105 Type certification is limited to a specific design, and may not involve the complete verification of material qualification and other generic procedures. Only those elements of the material qualification and generic procedures deemed critical for the design will be verified.

Guidance note:

Both the designer and manufacturer must decide on how to communicate the design and manufacturing process to the certifying body. In cases where the design or manufacture is

based on prior certification, the prior-certification sought must be clearly stated and referenced. All generic and specific documentation shall also be clearly identified.

---e-n-d---o-f---G-u-i-d-a-n-c-e---n-o-t-e---

Design and development processes

Generic qualification of methods and procedures

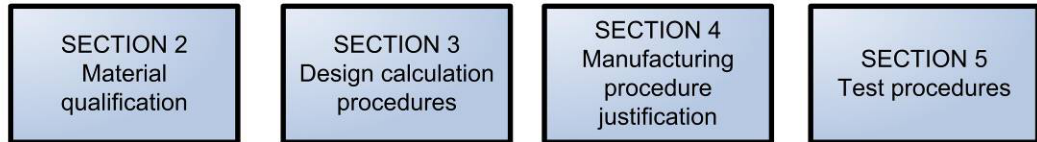

Design documentation for a blade type

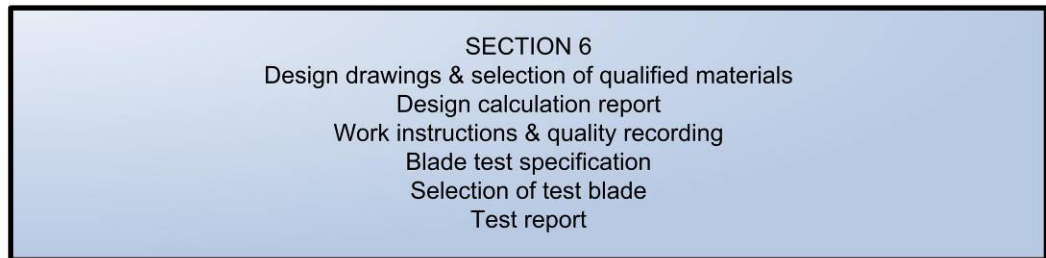

Manufacturing of blades

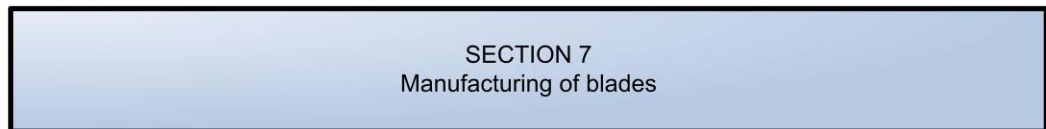

Figure 1 - Wind turbine design and development processes

C. Normative references

C100 DNV Standards

101 The standards in Table 1 include provisions, which through reference in this text constitute provisions of this standard.

Table 1 - DNV Offshore Service Specifications, Standards and Rules	
<i>Reference</i>	<i>Title</i>
DNV-OS-B101	Metallic materials
DNV-OS-J101	Design of Offshore Wind Turbine Structures

201 The principal methodology in the present standard represents design and testing practice applied in the wind turbine industry. For design of composite components for offshore installations DNV have issued another standard DNV OS-C501 which is based on a different methodology.

C200 IEC Type certification standards

201 The standards in Table 2 include provisions, which through reference in this text constitute provisions of this standard.

202 Latest issue of the standards shall be used unless otherwise agreed.

203 Other recognised standards may be used provided it can be demonstrated that these meet or exceed the requirements of the standards in Table 2.

204 Any deviations, exceptions and modifications to the design codes and standards shall be documented and agreed between the supplier, purchaser and verifier, as applicable.

Table 2 - IEC Type Certification Standards	
<i>Reference</i>	<i>Title</i>
IEC WT 01	IEC System for Conformity Testing and Certification of Wind Turbines, Rules and Procedures
IEC 61400-1	Wind Turbines - Part 1: Design Requirements
IEC 61400-23	Full Scale Testing of Wind Turbine Blades
IEC 61400-24	Lightning Protection for Wind Turbines

D. Informative references

D100 General

101 The documents in Table 3 and Table 4 include acceptable methods for fulfilling the requirements in this standard.

Table 3 - DNV Guidelines for wind turbines	
<i>Reference</i>	<i>Title</i>

DNV	Guidelines for Certification of Wind Turbine Power Plants
DNV/RISØ	Guidelines for Design of Wind Turbines

Table 4 - Other relevant references	
<i>Reference</i>	<i>Title</i>
ASTM C297	Determination of the core flat wise tension strength of sandwich structures.
ASTM C613	Standard Test Method for Constituent Content of Composite Prepreg by Soxhlet Extraction
ASTM D 5379	Standard Test Method for Shear Properties of Composite Materials by the V-Notched Beam Method
ASTM D1002	Standard Test Method for Apparent Shear Strength of Single-Lap-Joint Adhesively Bonded Metal Specimens by Tension Loading (Metal-to-Metal)
ASTM D1781	Standard Test Method for Climbing Drum Peel for Adhesives
ASTM D2344	Standard Test Method for Short-Beam Strength of Polymer Matrix Composite Materials and Their Laminates
ASTM D2584	Standard Test Method for Ignition Loss of Cured Reinforced Resins
ASTM D2734	Standard Test Methods for Void Content of Reinforced Plastics
ASTM D3039	Standard Test Method for Tensile Properties of Polymer Matrix Composite Materials
ASTM D3167	Standard Test Method for Floating Roller Peel Resistance of Adhesives
ASTM D3171	Standard Test Methods for Constituent Content of Composite Materials
ASTM D3410	Standard Test Method for Compressive Properties of Polymer Matrix Composite Materials with Unsupported Gage Section by Shear Loading
ASTM D3479	Standard Test Method for Tension-Tension Fatigue of Polymer Matrix Composite Materials
ASTM D3528	Standard Test Method for Strength Properties of Double Lap Shear Adhesive Joints by Tension Loading
ASTM D3529	Standard Test Method for Matrix Solids Content and Matrix Content of Composite Prepreg
ASTM D3530	Standard Test Method for Volatiles Content of Composite Material Prepreg
ASTM D3531	Standard Test Method for Resin Flow of Carbon Fibre-Epoxy Prepreg

ASTM D3532	Standard Test Method for Gel Time of Carbon Fibre-Epoxy Prepreg
ASTM D3776	Standard Test Methods for Mass Per Unit Area (Weight) of Fabric
ASTM D5528	Standard Test Method for Mode I Inter-laminar Fracture Toughness of Unidirectional Fibre-Reinforced Polymer Matrix Composites
ASTM D5868	Standard Test Method for Lap Shear Adhesion for Fibre Reinforced Plastic (FRP) Bonding
ASTM D695	Standard Test Method for Compressive Properties of Rigid Plastics
ASTM D792	Standard Test Methods for Density and Specific Gravity (Relative Density) of Plastics by Displacement
ASTM E1252	Standard Practice for General Techniques for Obtaining Infrared Spectra for Qualitative Analysis
ASTM E1356	Standard Test Method for Assignment of the Glass Transition Temperatures by Differential Scanning Calorimetry
ASTM E1545	Standard Test Method for Assignment of the Glass Transition Temperature by Thermo Mechanical Analysis
ASTM E168	Standard Practices for General Techniques of Infrared Quantitative Analysis
Danish Energy Agency	Recommendation for Design, Documentation and Test of Wind Turbine Blades.
ISO 14129	Fibre-reinforced plastic composites – determination of the in-plane shear stress/strain response, including the in-plane shear modulus and strength, by the $\pm 45^\circ$ tension test method.
ISO 17025	General requirements for the competence of calibration and testing laboratories
ISO 3207	ISO standards handbook – statistical methods
ISO 527	Plastics – Determination of Tensile Properties
ISO 9001:2000	Quality management systems, requirements
MIL-HDBK-17-1F	Volume 1. Polymer Matrix Composites Guidelines for Characterization of Structural Materials
MIL-HDBK-17-3F	Volume 3. Polymer Matrix Composites Materials Usage, Design, And Analysis

Guidance note:

The latest edition of the publications issued from Danish Energy Agency can be found at www.dawt.dk

---e-n-d---o-f---G-u-i-d-a-n-c-e---n-o-t-e---

E. Definitions

E100 Verbal forms

101 Shall: Indicates a mandatory requirement to be followed for fulfilment or compliance with the present standard. Deviations are not permitted unless formally and

rigorously justified, and accepted by all relevant contracting parties.

102 Should: Indicates a recommendation that a certain course of action is preferred or is particularly suitable. Alternative courses of action are allowable under the standard where agreed between contracting parties, but shall be justified and documented.

103 May: Indicates permission, or an option, which is permitted as part of conformance with the standard.

104 Can: Requirements with can are conditional and indicate a possibility to the user of the standard.

105 Agreement, or by agreement: Unless otherwise indicated, agreed in writing between contractor and purchaser.

E200 Terms

201 Abnormal load: Wind load resulting from one of a number of severe fault situations for the wind turbine, which results in activation of system protection functions. Abnormal wind loads are in general less likely to occur than loads from any of the normal wind load cases considered for the ULS.

202 Adhesive: A substance capable of holding two materials together by surface attachment.

203 Aero elastic: Concerned with the interactions between aerodynamic forces and structural deformation, in both static and dynamic cases.

204 Barcol hardness: A hardness value on a 0 to 100 scale obtained by measuring the resistance to penetration of a sharp steel point under spring loading.

205 Carbon fibres: Fibres made from a precursor by oxidation and carbonisation, and not having a graphitic structure.

206 Characteristic Load: The reference value of a load to be used in the determination of the design load. The characteristic load is normally based upon a defined quantile in the upper tail of the distribution function for load.

207 Characteristic load effect: The reference value of a load effect to be used in the determination of the design load effect. The characteristic load effect is normally based upon a defined quantile in the upper tail of the distribution function for load effect.

208 Characteristic resistance: The reference value of a structural strength to be used in the determination of the design resistance. The characteristic resistance is normally based upon a 5% quantile in the lower tail of the distribution function for resistance with 95% confidence.

209 Characteristic material strength: The nominal value of a material strength to be used in the determination of the design strength. The characteristic material strength is normally based upon a 5th percentile in the lower tail of the distribution function for material strength with 95% confidence.

- 210 Characteristic value:** A representative value of a load variable or a resistance variable. For a load variable, it is a high but measurable value with a prescribed probability of not being unfavourably exceeded during some reference period. For a resistance variable it is a low but measurable value with a prescribed probability of being favourably exceeded.
- 211 Coefficient of Variation (COV):** A statistical term referring to the variability of a sample data set, and is calculated by dividing the standard deviation by the mean.
- 212 Constituent:** In general this refers to any element of a larger grouping, for composites this refers to the matrix and the reinforcement.
- 213 Core:** The central member, usually foam or balsa, of a sandwich construction to which the faces of the sandwich skin are bonded.
- 214 Creep:** The time-dependent part of strain resulting from an applied stress.
- 215 Cure cycle:** The time/temperature/pressure cycle used to cure a thermosetting resin system or prepreg.
- 216 Cure:** To irreversibly change the properties of a thermosetting resin by chemical reaction.
- 217 Design limits:** Maximum or minimum values used in a design.
- 218 Design Manual:** A collection of instructions on design which is approved by the technical management
- 219 Differential Scanning Calorimetry (DSC):** Measurement of the energy absorbed (endotherm) or produced (exotherm) as a resin system is cured.
- 220 Environmental conditions:** Characteristics of the environment (altitude, temperature, humidity, etc.) which may affect the wind turbine's behaviour.
- 221 Expected value:** The mean value, e.g. the mean value of a load during a specified time period.
- 222 Extreme loads:** The maximum expected design loads the wind turbine blade is exposed to.
- 223 Fatigue critical:** Structure with a predicted fatigue life near the design fatigue life.
- 224 Fatigue Limit States (FLS):** Related to the states of fatigue failure due to the cumulative damage effect of cyclic loading.
- 225 Fatigue:** Degradation of the material caused by cyclic loading.
- 226 Fibre Reinforced Plastic (FRP):** A generic term for a composite material consisting of a polymeric matrix, and a reinforcing fibre.
- 227 Fibre:** A single homogenous strand of material used as a principal constituent in FRP materials due to its high axial strength and modulus. Also referred to as a filament.
- 228 Filament:** See above.
- 229 Fill:** The transverse yarns in a woven fabric running perpendicular to the warp. Also referred to as a weft.
- 230 Gel coat:** A resin system applied to a mould surface to provide an improved surface for the finished FRP material.
- 231 Gel time:** The amount of time taken for a resin to advance to the gelation point.
- 232 Gelation:** The point in a resin's cure cycle where resin viscosity exceeds a specified value.
- 233 Glass Transition:** The reversible change in an amorphous polymer from a hard and relatively brittle condition to a viscous or rubbery one.
- 234 Glass Transition Temperature (T_g):** The approximate midpoint of the temperature range over which the glass transition takes place in a polymer.
- 235 Guidance note:** Information in the standards in order to increase the understanding of the requirements.
- 236 Gust:** Sudden and brief increase of the wind speed over its mean value.
- 237 Hand lay up:** The process of successive build up of plies in a mould by hand.
- 238 High Performance Liquid Chromatography (HPLC):** The analysis of resin composition through the dissolving of a resin in solution, and then analysing through selective elution.
- 239 Inclusion:** A physical discontinuity within a material, usually consisting of encapsulated solid material, often degrading the structural properties.
- 240 Independent third parties:** Accredited or nationally approved certification bodies.
- 241 Infrared Spectroscopy:** The qualitative assessment of polymer constituents through infrared analysis.
- 242 Inspection:** Activities such as measuring, examination, testing, gauging one or more characteristics of an object or service and comparing the results with specified requirements to determine conformity.
- 243 Interface:** The boundary between individually distinguishable constituents of an FRP material or joint.
- 244 Inter-laminar shear:** Shearing force tending to produce a relative displacement between two laminae in a laminate.
- 245 Inter-laminar:** Descriptive term pertaining to an object, event, or potential field referenced as existing between two or more adjacent laminae.
- 246 Isotropic:** Having uniform properties in all directions.
- 247 Kitting:** The process of assembling cut plies in the order in which they will be placed on the mould to form the laminate during lay up.
- 248 Lamina:** A single ply or layer in a laminate made up of a series of layers.

RP-2005-33 Rev.1

- 249 Laminae:** The plural of lamina.
- 250 Laminate:** A product made by the bonding of individual laminae together.
- 251 Limit State:** A state beyond which the structure no longer satisfies the requirements. The following categories of limit states are of relevance for structures: ultimate limit state (ULS), fatigue limit state (FLS), and serviceability limit state (SLS).
- 252 Load effect:** Effect of a single design load or combination of loads on the equipment or system, such as stress, strain, deformation, displacement, motion, etc.
- 253 Mat:** A fibrous material consisting of randomly chopped, short, or swirled fibres loosely held together with a binder.
- 254 Matrix:** The essentially homogenous constituent of an FRP material that binds and protects the fibres.
- 255 Mean:** Statistical mean over observation period.
- 256 Moisture content:** The amount of moisture in a material determined under specified conditions, and expressed as a percentage of the mass of the moist specimen.
- 257 Mould:** The cavity into which the FRP material is placed, cured, and takes its final form.
- 258 Neat resin:** Resin to which nothing (additives, reinforcements, and so on) has been added.
- 259 Non-destructive testing (NDT):** Structural tests and inspection of welds by visual inspection, radiographic testing, ultrasonic testing, magnetic particle testing, penetrant testing and other non-destructive methods for revealing defects and irregularities.
- 260 Offshore Standard:** The DNV offshore standards are documents which presents the principles and technical requirements for design of offshore structures. The standards are offered as DNV's interpretation of engineering practice for general use by the offshore industry for achieving safe structures.
- 261 Orthotropic:** Having three mutually perpendicular planes of elastic symmetry.
- 262 Partial safety factor method:** Method for design where uncertainties in loads are represented by a load factor and uncertainties in strengths are represented by a material factor.
- 263 Peel Ply:** A layer of open-weave material applied directly to the surface of a prepreg lay up. The peel ply is removed from the cured laminate immediately before bonding, leaving a clean surface that needs no additional surface preparation.
- 264 Ply drop:** The transition point in a laminate between different thicknesses, or number of lamina layers.
- 265 Ply:** The layers (lamina) that make up a stack (laminate).
- 266 Polymer:** A high molecular weight organic compound, whose structure can be represented by a repeated small unit.
- 267 Pot life:** The length of time that a catalysed thermosetting resin system retains a viscosity low enough to be used in processing.
- 268 Prepreg:** Ready-to-mould material in roving form (cloth, mat, unidirectional fibre, or paper) impregnated with resin and stored for use. The resin is partially cured and supplied to the manufacturer for finishing and curing.
- 269 Purchaser:** The owner, or another party acting on his behalf, responsible for procuring materials, components or services intended for the design, construction or modification of a structure.
- 270 Quasi-isotropic laminate:** A laminate approximating isotropy by orientation of plies in several or more directions.
- 271 Recommended Practice (RP):** The recommended practice publications cover proven technology and solutions which have been found by DNV to represent good practice, and which represent one alternative for satisfying the requirements stipulated in the DNV offshore standards or other codes and standards cited by DNV.
- 272 Redundancy:** The ability of a component or system to maintain or restore its function when a failure of a member or connection has occurred. Redundancy can be achieved for instance by strengthening or introducing alternative load paths.
- 273 Resin system:** A polymer and their associated hardeners, catalysts, accelerator, etc., which can be converted to a solid by application of energy, normally in the form of elevated temperature.
- 274 Resin:** A mixture of resin and ingredients such as catalyst, initiator, diluents, etc., required for the intended processing and final product.
- 275 Roving:** A number of yarns collected into a parallel bundle with little or no twist.
- 276 S-N diagram:** The plot of stress against number of cycles to fatigue failure.
- 277 Scheduled maintenance:** Preventive maintenance carried out in accordance with an established time schedule.
- 278 Serviceability Limit State (SLS):** Concerns those states at which the structure starts to behave in an unsatisfactory fashion due to e.g., excessive deformations, or vibration. Implies that deformations in excess of tolerance without exceeding the load-carrying capacity i.e. they correspond to tolerance criteria applicable to normal use.
- 279 Substrate:** the material to which a paint or adhesive is bonded.
- 280 Tack:** Stickiness of an adhesive or FRP prepreg material.

PROPOSAL

RP-2005-33 Rev.1

281 Tape: Unidirectional prepreg fabricated in specified widths.

282 Thermoplastic: Capable of being repeatedly softened by an increase in temperature, and capable of being moulded or extruded in this stage.

283 Thermosetting: A plastic that, when cured by application of heat or chemical means, changes into a substantially infusible and insoluble material.

284 Tow: an untwisted bundle of continuous fibres, commonly referring to the glass and carbon fibres used in uni directional composites.

285 Tower: Structural component, which forms part of the support structure for a wind turbine. For offshore wind turbine structures, this usually extends from somewhere above the still water level to just below the nacelle of the wind turbine.

286 Ultimate Limit States (ULS): Concerns those states related to the limit of load-carrying capacity i.e. to maximum load carrying resistance.

287 Unidirectional laminate: A composite laminate in which substantially all of the fibres are oriented in the same direction.

288 Veneer: A thin sheet of wood sliced or peeled on a veneer machine. Plywood is then comprised of multiple veneers.

289 Verification: Examination to confirm that an activity, a product or a service is in accordance with specified requirements.

290 Void Content: Volume percentage of voids (usually less than 1%) in a properly cured composite.

291 Voids: Air or gas that has been trapped and cured into a laminate. Voids are incapable of transferring structural stresses.

292 Volatiles: Materials in a resin formulation, such as water and alcohol, capable of being driven off as vapour at room temperature or during an elevated temperature cure.

293 Warp: The yarn running lengthwise in a woven fabric.

294 Weft: The transverse yarns in a woven fabric running perpendicular to the warp, also referred to as fill.

295 Wind shear: Variation of wind speed across a plane perpendicular to the wind direction.

296 Woven fabric: A material constructed by interlacing yarns or fibres to form basic fabric patterns.

297 Yarn: An assemblage of twisted fibres to form a continuous length suitable for use in woven fabric.

F. Abbreviations and Symbols

F100 Abbreviations

101 Abbreviations as used in this standard.

<i>Abbreviation</i>	<i>In full</i>
ASTM	American Society for Testing and Materials
CLD	Constant Lifetime Diagram
CFRP	Carbon Fibre Reinforced Plastics
COV	Coefficient Of Variation
CPT	Cured Ply Thickness
DNV	Det Norske Veritas
DSC	Differential Scanning Calorimetry
FAW	Fibre Areal Weight
FE	Finite Element
FEA	Finite Element Analysis
FLS	Fatigue Limit State
FRP	Fibre Reinforced Plastics
FV	Fibre Volume
GFRP	Glass Fibre Reinforced Plastic
IEC	International Electro technical Commission
ILSS	Inter Laminar Shear Strength
IR	Infra Red
ISO	International Standards Organisation
MPa	Mega Pascal (1 million Pascal)
PVC	Poly Vinyl Chloride
SLS	Serviceability Limit State
SRF	Safety Reserve Factor
UD	Uni Directional
ULS	Ultimate Limit State
UV	Ultra Violet

F200 Symbols

201 Latin characters

E	Young's modulus
\bar{x}	Sample mean
F	Load
f_d	Design resistance or capacity
f_k	Characteristic stress
F_k	Characteristic load
G	Shear modulus, or strain energy release rate
$G_{critical}$	Critical strain energy release rate
H_n	Tsai-Wu interaction parameter
P	Load
P_e	Elastic critical load
P_f	Ultimate failure load
R	Resistance
R_k	Characteristic resistance
s	Sample standard deviation

S_d	Local stress or strain
-------	------------------------

202 Greek characters

γ_A	Partial analysis factor
γ_{ef}	Partial factor for error in fatigue formulation
γ_f	Load factor
γ_m	Partial material resistance factor
γ_n	Partial consequence of failure factor
γ_{sf}	Partial factor for blade to blade variation
α	Strain amplitude
ϵ	Strain
ϵ_e	Elastic critical strain
ϵ_n	Principal strain
μ	Population mean
ρ	Density
σ	Population standard deviation
σ_e	Elastic critical stress
σ_n	Principal stress
τ	Shear stress
v	Coefficient of variation

203 Subscripts

A	Analysis factor
c	Compressive strength
corr	Corrected
crit	Critical
d	Design value (includes safety factors)
e	Elastic critical
eff	Effective
equivalent	Equivalent
f	Fibre or failure
k	Characteristic
lin	Linear
m	Material
nn	Ply/lamina coordinate system
nonlin	Non linear
t	Tensile strength
test	Test
xx	Laminate coordinate system

PROPOSAL

RP-2005-33 Rev.1

F300 Composite coordinate system

301 The coordinate system shown at Figure 2 is recommended for the analysis of composite materials, and is referred to throughout this standard. Numerals (1, 2, and 3) refer to the laminae/ply coordinate system; letter (x, y, and z) refer to the laminate coordinate system.

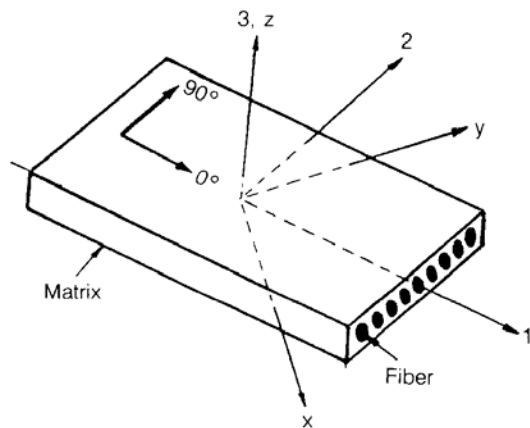

Figure 2 - Composite coordinate system

SECTION 2 MATERIAL QUALIFICATION

A. General

A 100 General

101 The material qualification is to at least include:

- Requirements for repeatability of manufacturing processes (e.g. curing control for resins and adhesives).
- Requirements for traceability of materials (e.g. name and trademark of manufacturer, material grade, batch number).
- Requirements for material storage (e.g. control of temperature, humidity and shelf life).
- Characteristic material parameters for all relevant limit states including: minimum and maximum service temperatures, and other environmental conditions (e.g., strength, toughness, density, cold deformability, ageing characteristics, resistance to rot and sun light).
- The material qualification shall cover changes in material properties over the range of service temperatures such as embrittlement at low temperatures and drastic changes near the glass transition temperature for the materials.
- Purchase specifications for the individual materials. The specifications shall as a minimum cover: strength properties, testing methods, batch size, frequency of testing, certification, marking (labels/colour codes).
- Qualification scheme for new suppliers of materials. The scheme shall identify test methods used to document material compatibility with existing approved materials, as well as the material's characteristic material parameters.
- Qualification records for the approved suppliers.

Guidance note:

The embrittlement may typically not influence stiffness or strength for the material without imperfections. The embrittlement may have a drastic impact on the sensitivity to imperfections.

Embrittlement is critical for low alloy steels where it is controlled by Charpy or Crack Tip Opening Displacement testing. Embrittlement at low temperatures can also be critical for polymers such as resins, adhesives, fillers, paints and gel coats

---e-n-d---o-f---G-u-i-d-a-n-c-e---n-o-t-e---

A200 Characteristic Material Properties

201 In order to account for uncertainty and variability in the materials, material properties shall be calculated as characteristic values using statistical methods.

202 In the context of composite materials, the characteristic strength (R_k) is given by the lower limit of the population's 5th percentile with a 95% confidence. The 5th percentile corresponds to a value below which only 5% of the population is expected to lie.

203 In practise, strength characterisation is conducted through a test program with a finite sample number (n) of

individual tests. The aim of the test program is to estimate the mean (μ) and variance (σ^2) of the population's probability distribution.

204 As only a finite number of specimens in the sample will be tested (n), the uncertainties in estimating the population's probability distribution parameters from sample values shall be accounted for using statistical methods.

205 The test program should firstly determine the key statistical parameters of the sample: \bar{x} (sample mean), and s^2 (sample variance).

Where:

$$\bar{x} = \frac{1}{n} \sum_{i=1}^n x_i, \text{ and}$$

$$s^2 = \frac{1}{n-1} \sum_{i=1}^n (x_i - \bar{x})^2$$

206 Population variance (σ^2) known – k_1 . In the case of known variance, and normally (Gaussian) distributed strength, the characteristic strength is to be calculated as follows:

$$R_k = \bar{x} - k_1 \cdot \sigma$$

Where:

k_1 can be determined by the formula below, or taken from the values given in Table 5.

σ is the known standard deviation (square root of variance) of the population.

$$k_1 = Z_{\frac{\alpha}{2}} \left(1 + \frac{1}{\sqrt{n}} \right)$$

Where:

$Z_{\frac{\alpha}{2}}$ can be taken as 1.645 for a 95% confidence

207 Population variance (σ^2) unknown – k_2 . In the case of unknown variance, and normally (Gaussian) distributed strength, characteristic strength is to be calculated as follows:

$$R_k = \bar{x} - k_2 \cdot s$$

Where:

k_2 values given in Table 5.

s is the sample standard deviation (square root of variance) of the tested sample

Table 5 – Determination of k_m for a 5th percentile lower limit with 95% confidence for normally distributed population.

No. of samples (n)	k_1	k_2
5	2.38	4.21
6	2.32	3.71
7	2.27	3.40
8	2.23	3.19
9	2.19	3.03
10	2.17	2.91
11	2.14	2.82
12	2.12	2.74
13	2.10	2.67
14	2.08	2.61
15	2.07	2.57
20	2.01	2.40
50	1.88	2.07
100	1.81	1.93
∞	1.645	1.645

Guidance note:

For further information see ISO 3207.

---e-n-d---o-f---G-u-i-d-a-n-c-e---n-o-t-e---

208 Other more advanced statistical methods and assumptions may be used to determine characteristic strength (R_k), when provided with appropriate justification. This includes methods that assume two-parameter Weibull strength probability distributions, such as those given in the aerospace industry accepted MIL-HDBK-17.

209 Partial safety factors shall be used in accordance with the definition of characteristic strength to develop the material’s allowable design resistance or capacity (f_d).

210 The characteristic material stiffness is defined as the mean value, and shall be established with 95% confidence.

A300 Quality system requirements

301 The documentation for the material qualification shall be open to all individuals involved in design, purchase and manufacturing. The documentation is preferably to be organised as a consolidated manual.

B. FRP materials

B100 General

101 This section provides an overview of the qualification plan required for the development and control of mechanical properties for the GFRP materials utilised in wind turbine blade structure. The aim of the qualification plan is to provide a logical basis for the wind turbine blade design and testing.

Guidance note:

There are some significant differences between FRP materials and traditional isotropic materials that make the material qualification approach unique. These include:

- Material anisotropy: the properties of FRP materials are often significantly different in different directions.
- Brittle failure: FRP materials fail with little or no plastic deformation, preventing the favourable strain redistributions due to local yielding that is often seen in traditional metallic structures at ultimate loads.
- Complicated failure modes: the failure modes are often more complicated than for isotropic materials, and can often be counter-intuitive. These failure modes are discussed in further detail in section 3.
- Material in-homogeneity: due to the inherent variability of the FRP manufacturing process, there can often be unintended variation such as: local fibre volume changes, and fibre orientation changes that affect the mechanical properties.
- Many of the constituents are sensitive to environmental conditions. An example of this is thermosetting resins, which through their moisture absorption are sensitive to moisture.

---e-n-d---o-f---G-u-i-d-a-n-c-e---n-o-t-e---

102 The detailed design of a FRP structure can not rely purely on traditional analyses alone as is normally the case with isotropic materials such as steel. The basis for design of a FRP structure should be developed with a building-block approach, where a progressively decreasing number of more complicated structures are analysed and tested; culminating in a full scale structural blade test. This relationship is shown in Figure 3.

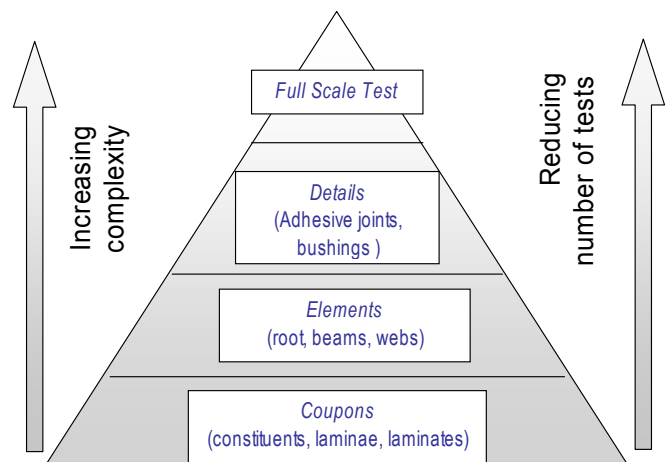

Figure 3- The Building Block Approach

103 The approach can be summarised as follows:

- Coupons: a large number of tests are conducted at the coupon level, where confidence in repeatable physical properties is developed. Procurement specifications are developed for the individual constituents, and allowable design variables developed for lamina/laminate combinations.
- Elements: critical areas from the design analysis identify elements for further testing and analysis at the extreme design conditions. This may include such tests as stacked laminates representing critical beam and web cross-sections along the blade length.
- Details: increasingly more complicated tests are developed to evaluate more complicated loading

PROPOSAL

RP-2005-33 Rev.1

conditions and failure modes, such as the inclusion of drilled holes and root sections.

- Full Scale Test: here the final representative design is static and fatigue tested at the design conditions for a final verification of the blade’s structural resistance.

104 The number of tests required for each level must be tailored for each design activity, with the blade designer responsible for the development of a reasonable number of tests at each stage. In general terms, a larger number of tests are required in the beginning; as confidence is developed and the analysis refined based on these test results, a decreasing number of tests is required for meaningful analysis.

105 The qualification plan shall include all fibre and resin types used within the design, including any alternative materials utilised during manufacture.

106 The four suggested elements of the qualification plan will now be discussed in detail.

B200 Coupon level ultimate strength qualification

201 Coupon level testing can be considered on three different levels:

- Uncured constituents.
- Cured lamina/laminate physical properties.
- Cured lamina/laminate mechanical properties.

202 The qualification of uncured constituents is focused on the repeatability of manufacture. Generally the properties tested have little influence on the characteristic strength. The properties in Table 6 should be tested by the vendor, and where the manufacturer believes the property critical to the manufacturing process, acceptance testing should be conducted to verify that an error did not occur during shipment from the vendor to the end application.

Table 6 - Uncured constituent testing	
<i>Test Property</i>	<i>Recommended test</i>
Resin Content	ASTM D3529, C613
Volatile Content	ASTM D3530
Gel Time	ASTM D3532, ISO 15040
Resin Flow (prepreg)	ASTM D3531, ISO 15034
Fibre Areal Weight	ASTM D3776, ISO 4605
IR (Infrared Spectroscopy)	ASTM E1252, E168
HPLC (High Performance Liquid Chromatography)	-
DSC (Differential Scanning Calorimetry)	ASTM E1356, ISO 11357

203 The qualification of the cured lamina/laminate physical properties is conducted to provide confidence in the physical properties of the fibre matrix combination following processing. The properties in Table 7 should be

evaluated by the designer for each FRP system following the manufacture of representative test coupons:

Table 7 - Cured lamina/laminate testing	
<i>Test Property</i>	<i>Test Method</i>
Cured Ply Thickness	-
Fibre Volume	ASTM D3171 (CFRP), D2584 (FRP)
Resin Volume	ASTM D3171 (CFRP), D2584 (FRP)
Void Content	ASTM D 2734
Cured Neat Resin Density	ASTM D792, ISO 1675
Glass Transition Temperature	ASTM E1545

204 The properties obtained from these tests may be used to develop mature material specifications for material procurement, as well as used to develop acceptable limits for acceptance testing of critical materials.

205 The glass transition temperature shall be considered as detailed in section 3 D600.

206 The qualification of cured lamina/laminate mechanical properties is evaluated by the designer to provide confidence in the resultant lamina/laminate mechanical properties of the particular fibre matrix combination used in the design. Mechanical properties shall be statistically determined from test results. It is recommended that the testing described in Table 8 (refer to coordinate system in section 1 F300) is conducted to develop representative material factors allowed. A minimum of three material batches with independent cure cycles is recommended to manufacture the test coupons.

Table 8 - lamina/laminate mechanical property testing		
<i>Test Property</i>	<i>Test Method</i>	<i>Number</i>
0° Tensile Modulus, Strength, and Poisson's ratio	ASTM D 3039, ISO 527	3x4
90° Tensile Modulus, Strength, and Poisson's ratio	ASTM D 3039, ISO 527	3x4
0° Compressive Strength and Modulus	ASTM D695, D3410, ISO 14126	3x6
90° Compressive Strength and modulus	ASTM D695, D3410, ISO 14126	3x6
In Plane Shear Modulus and Strength	ASTMD5379, ISO 14129	3x4
Inter-laminar Shear Strength (short beam)	ASTM D 344, ISO 14130	3x6

207 Moduli and Poisson's ratio can be obtained by direct measurement during strength testing, and reduced to only two of the three material batches.

208 90° tensile and 90° compressive strength testing is only required for:

- UD tapes utilised in the design that are experiencing transverse loading (i.e., longitudinal loading *is not* dominating);
- For woven fabric where there is a significant difference between the warp and weft/fill directional properties.

Guidance note:

DNV test experience suggests that a 10% to 20% strength difference is typical even if the same amount of fibres goes in both the warp and weft/fill directions.

---e-n-d---o-f---G-u-i-d-a-n-c-e---n-o-t-e---

209 As ply thickness is entirely dependant on matrix content, and axial strength is typically dominated by fibre content, the test data must be corrected for ply thickness variations (fibre volume) to get representative strength results. This is done through normalisation of the strength and moduli properties for a specified constant fibre volume. Poisson's ratio, 90° axis, and in-plane / Inter-laminar shear characteristics are not fibre-dominated and therefore do not require data normalisation.

210 One approach for data normalisation is known as the 'Cured Ply Thickness' approach, which relies on the direct relationship between FV and the CPT. Here, test data at different achieved FVs can be normalised to a common FV. This approach can be carried out according to the following or equivalent method:

$$F_{normalised} = F \times \frac{CPT \times \rho_f}{FAW} \times FV_{normalising}$$

Where the FV to which the data is to be normalised is given by:

$$FV_{normalising} = \frac{h_{fn}}{CPT_n} \text{ where:}$$

h_{fn} is the equivalent thickness of the solid reinforcement fibre in one ply (normalising value)

CPT_n is the Cured Ply Thickness, the total laminate thickness divided by the number of plies (normalising value)

And:

F is the strength property under consideration

CPT is the Cured Ply Thickness, the total laminate thickness divided by the number of plies

$FV_{normalising}$ is the design specified fibre volume for the lamina/laminate

ρ_f is the density of the fibre

FAW is the Fibre Areal Weight of a single lamina/ply (i.e., the mass of fibre in a unit area of lamina/ply)

210 The laminate material qualification does not explicitly consider the influence of laminate effects such as ply drops, fibre misalignment, scale and detail effects, manufacturing process, and individual workmanship. Some of these effects (such as ply drops, holes, and impact damage) can be taken into consideration during preparation of the coupons. Otherwise, they shall be considered both during in higher scale testing and through development of the design allowable strengths with the material factor as detailed in section 3.

211 Further quantification of these larger scale effects can be obtained through element level qualification.

B300 Coupon level S-N curve development

301 Test coupons shall be tested cyclically at the relevant R-ratio under investigation, where the R-ratio is defined as:

$$R = \frac{S_{min}}{S_{max}}$$

Where:

S_{min} The minimum cyclic stress applied

S_{max} The maximum cyclic stress applied

302 Typically used R-ratios are shown in Figure 4.

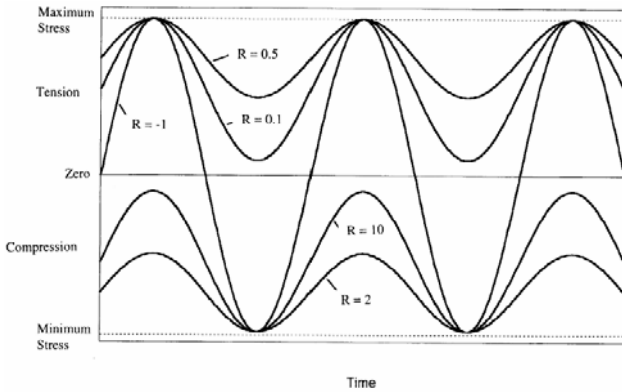

Figure 4 - Typical R-ratios

303 The S-N curve is to be developed based on characteristic material properties.

Guidance note:

Details of fatigue limit state (FLS) analysis is given in Appendix H.

DNV test experience within the OPTIMAT program suggests the use of a simple Constant Lifetime Diagram (CLD) developed from a single R-ratio coupon test is generally not on the conservative side.

It is required to test at least at R = -1, 0.1, and R=10 to develop a meaningful CLD from test data.

Following fatigue life calculations for wind turbine blades using CLDs, particular attention should be given to the test data in the CLD that has a dominating influence on the life. It is difficult to define interpolation algorithms that are conservative throughout the regions of the CLD.

---e-n-d---o-f---G-u-i-d-a-n-c-e---n-o-t-e---

304 The development of laminate S-N curves for a number of R-ratios is required for the subsequent FLS analyses. Test coupons shall be manufactured from laminates representative of the final application. Detailed test programmes for each R-ration can be based on the basis of Table 9.

Table 9 - laminate fatigue strength testing		
<i>Test Property</i>	<i>Test Method</i>	<i>Number</i>
Tension-tension fatigue	ASTM D3479	10

Guidance note:

The ASTM D3479 fatigue test method deals with tension-tension fatigue only. For R-ratios of R=-1, and R=10, careful consideration should be given to the testing method to avoid laminate bending and buckling under compression.

---e-n-d---o-f---G-u-i-d-a-n-c-e---n-o-t-e---

B400 Element level qualification

401 Following the initial global analysis of the structure (discussed further in section 3), critical areas within the

wind turbine structure will become evident. These critical areas can then be further evaluated through element level testing.

402 The element may be representative of any critical area within the blade structure, typically cross sections of generic beam, flange, and web cross-sections. The development of representative laminates can then be tested to evaluate the effects of discontinuities, stacking effects, and other scale effects on the relevant failure modes. Special attention should be given to matrix-sensitive failure modes (such as compression, in-plane and out of plane shear). The effects of holes and notches on the laminate may also be investigated at this level to provide greater understanding of the element response.

403 Results from this testing can then be compared to the analysis, updating the analysis where necessary for increased accuracy.

B500 Detail level qualification

501 The design can be qualified at the detail level through further testing and analysis, to provide further confidence in structural details. This may be required to investigate complex structural arrangements (such as hub attachment, and flange bonding) under complex three dimensional loading conditions.

502 There are no standard tests at this level, and they must be developed by the designer to be representative of the relevant loading and failure conditions being investigated if they are to be meaningful. The sample sizes will be tailored for their criticality and typically be small (. Following the detail level qualification, a final full scale test is conducted.

B600 Full scale test

601 The purpose of the full scale test is a final validation of the numerous design assumptions made through the design development, and the qualification plan. It is a more representative application of the expected design conditions in service, and accurately takes into account global effects. The full scale test results should also be compared against the original design analysis as further validation.

602 Further details on the full scale testing requirements are provided in Section 5.

B700 Qualification of substitute materials

701 For the qualification of substitute materials into a design with prior certification, the above tests shall also be completed. For uncured constituent properties, the acceptance criteria for the substitute material shall take into account the manufacturing process. For the cured laminate mechanical properties, the strength values of the substitute material shall exceed that of the cured laminate being substituted for, and the modulus shall be as close as possible (in order to match the global stiffness). Where these conditions have not been met, the blade may require

recertification of elements of the original design and manufacturing process.

C. Sandwich core materials

C100 Sandwich core materials

101 The material qualification for sandwich core materials shall as a minimum include the following:

- Characteristic strength and stiffness properties that are utilised in the design shall be determined by test.
— The materials shall be suitable for their expected service and manufacturing cure temperatures. Reference is made to Sec. 3 D600.
— Interface to facing laminae.
— Wooden (typically balsa) cores shall be environmentally treated to prevent moisture ingress and degradation.

D. Adhesives

D100 Paste Adhesives

101 The material qualification for adhesives shall consider the following as a minimum:

- Surface preparation of adherents
— Specified mixing ratios, and application methods
— Mating part dimensional tolerances
— Bond thickness tolerances
— Cure cycle
— Post bond inspection requirements
— Ductility, shear and peeling strength characterisation
— Failure modes (see Appendix F)
— Environmental effects and ageing

102 Characteristic strengths for adhesives should be based on test with representative adherents. These characteristic strengths should be used where the relevant adhesive loading mode can be demonstrated. A suitable test basis for this strength characterisation is listed in Table 10. A minimum of two adhesive batches are recommended to manufacture the test joint pieces.

Table 10 - Recommended adhesive strength characterisation tests

Table with 3 columns: Test Property, Test Method, Number. Rows include Single Shear (FRP), Double Shear (FRP), Double Shear (metals), Flat wise Tension, Peel (floating roller), Peel (climbing drum), and Mode I fracture (opening).

103 The glass transition temperature of the adhesive shall be considered as per section 3D 600.

104 The effect of stress concentrations on resistance shall be part of the qualification of adhesives.

Critical properties should be considered for additional ongoing testing for quality control through the quality system.

D200 Adhesive durability considerations

201 Adhesive fatigue criteria should be based on one or a combination of the following approaches:

- Fracture mechanics approach, based on limiting the strain energy release rate (G)
— Simplified shear and peel stress limits, based on demonstrated experience and/or testing
— Traditional S-N curve development, and subsequent FLS analysis

Guidance note:

Shear tests have not traditionally provided a reliable measure of adhesive durability (including fatigue). Peel testing often proves more reliable for evaluating weak adhesive bonds.

---e-n-d---o-f---G-u-i-d-a-n-c-e---n-o-t-e---

202 For traditional FLS analysis, the development of adhesive joint S-N curves should be based on test coupons manufactured from adherents representative of the final joint's configuration. A minimum of 5 coupon test points at the relevant R-ratio is recommended to provide confidence in the S-N curve. The S-N curve is to be developed from characteristic values.

Guidance note:

Traditional FLS analysis of adhesive joints is not a well documented area. Early aerospace research suggests that strain rates can be critical for fatigue response; counter-intuitively adhesives can sometimes fail earlier at lower strain rates.

---e-n-d---o-f---G-u-i-d-a-n-c-e---n-o-t-e---

E. Laminated wood

E100 Laminated Wood

101 The qualification of wood should be based on the same principles as FRP materials in section B100, with the wood lamina being considered as reinforcing fibre.

PROPOSAL

RP-2005-33 Rev.1

102 Data for strength of tensile and compressive wood shall be corrected for effects of density. The purchase specification shall specify acceptable densities.

103 The procedures for purchase and storage of wood shall control the moisture content during manufacturing. The characteristic strength of wood shall be based on test data that are corrected to represent the worst possible moisture. The variation in moisture content for the wood for a blade should be within $\pm 2\%$.

Guidance note:

The wood can normally be enclosed such that the moisture content will not increase when the blade is in service. Creep and ageing of the wood over the service life can normally be neglected for controlled moisture content below 10%.

---e-n-d---o-f---G-u-i-d-a-n-c-e---n-o-t-e---

F. Surface Finishing

F100 Fillers

101 Surface fillers are typically used to build up smooth aerodynamic surfaces. Although they do not attribute to the structural strength of the blade laminate, failure of the filler can lead to other failure modes of the parent laminate, e.g. moisture ingress and erosion, and further delamination of covering paint / gel coat.

102 Surface fillers should be qualified based on the following minimum structural properties:

- Mechanical strain, is to exceed the maximum design strain of the expected substrate (recommended minimum of 2%)

F200 Paints and Gel coats

201 Paint and gel coats are used as coatings for wind turbine blades. Gel coats are applied in the mould prior to lay up. Gel coats are normally based on the same system as the resin. Gel coats normally need repairs and supplementary painting of bond lines after blade assembly. Paints are applied after the blade has been assembled. Typically polyurethane and epoxy paints are used.

202 As the paint/gel coat provides environmental protection for the structural FRP substrate, the paint/gel coat system is to therefore provide:

- A smooth surface finish to minimise skin friction drag, and optimise power production
- Environmental protection of the substrate (the structural FRP material)
- Durability through the design life

203 The goal of the material qualification program is to provide this optimal protection, with minimum maintenance over the design life. Due to the numerous complexities and variables in the actual environment experienced by a wind turbine blade, qualification by test provides a comparative basis to other paints only, and does not guarantee protection through the design life. Ideally qualification should also be based on demonstrated

previous experience by the paint manufacturer in representative conditions (i.e. other wind turbine blades).

204 The material qualification for blade surface paints/gel coats is to assess the following physical and durability properties:

- Substrate adhesion (recommended minimum of 2-3 MPa for pull off tests)
- Mechanical strain, is to exceed the maximum design strain of the expected substrate (recommended minimum of 2%)
- Reflectivity (or gloss)
- Water immersion
- UV exposure
- Erosion, in particular tip leading edge areas from hail, sand, and dust
- Chemical resistance (if relevant)

Guidance note:

For paints with prior qualification: in offshore (NORSOK M-501), general (ISO 12944), and aircraft (MIL-PRF-85285, AMS 3095) use, prior individual qualification testing elements may be accepted if similar test substrates have been used.

Blade reflectivity requirements may depend on local legislation; Danish wind turbine blades for example currently have reflectivity limits to reduce visual impact.

---e-n-d---o-f---G-u-i-d-a-n-c-e---n-o-t-e---

205 Sample substrates for qualification shall be made from representative laminates indicative of the end application; the same method of paint application used during the actual final manufacturing surface finish shall be used. Individual test methods shall follow internationally accepted standards and specifications (such as ISO, or ASTM).

206 Critical properties should be considered for additional ongoing testing through the quality system.

F300 Paint Application

301 In order to optimise the paint system performance, and minimise maintenance requirements through the service life, the following additional considerations are recommended:

- The use of primers
- Environmental control of the paint application area, including temperature, humidity, sunlight, and dust.
- Surface preparation prior to painting; should be degreased, abraded, clean, and dry
- Control the paint application process through dedicated painting procedures. These procedures should be based on the paint manufacturer's recommendations, and include the minimum and maximum required dry film thickness.

PROPOSAL

RP-2005-33 Rev.1

- Workmanship through defined qualification requirements for paint operators involved in the paint application process
- Inspection and test requirements during and after the paint application
- Weight and balance control after painting
- Ongoing inspection requirements and in-field repair procedures

G. Metallic materials

G100 Metallic materials for bushings etc.

101 Metallic materials do normally not need qualification if the design is carried out according to recognised standards and guidelines such as DNV Guidelines for certification of wind turbine power plants, or DNV-OS-B101.

102 Bushings should be qualified by load test, where the laminate, adhesive, and bushing arrangement is representative of the end application.

Guidance note:

Bushings may also be tested through inducing tension in one bushing and compression in the two neighbour bushings. Due to different boundary conditions, this testing does not simulate the same stress distribution in the bushings as experienced in service. In service the blade is bolted to a hub or pitch bearing and a bushing meet approximately the same load as its neighbours. This inaccuracy should be considered when using the test results for qualification of the design.

---e-n-d---o-f---G-u-i-d-a-n-c-e---n-o-t-e---

SECTION 3 DESIGN ANALYSIS

A. General

A100 Objective

101 This section provides a general framework for the analytical verification of wind turbine blade structure.

102 The blade structure shall fulfil a number of design criteria defined for a series of relevant limit states. The analytical verification of sufficient blade capacity shall be carried out accordingly by verifying that the structural load does not exceed the material resistance associated with the respective limit states.

A200 Quality system requirements

201 The design manual of the blade designer shall specify details of the design processes which are covered in this section when the emphasis is on the specific materials, structural lay-out and processes relevant for the actual designs.

202 A specific qualification scheme shall be included for engineers who perform or supervise FEA.

A300 Processes

301 An overview of the processes involved with the analytical verification of blade structure is illustrated in Figure 5. The selection of partial safety factors and definition of characteristic values are not included in this overview, being specified later in this section.

302 The structural input for aero-elastic modelling of the blade shall be verified. In the initial design phase this can be accomplished by FEA or by analytical modelling of the blade's stiffness and mass. Following type testing, these models shall be compared against test data. Further details of the verification are given in Section 6 and Appendix B.

303 Detailed aero elastic calculations shall be carried out according to established methods. The aero-elastic calculation results in combined time-series of deformations and stresses in all relevant deformation modes of the blade. The aero-elastic calculation is not covered further in this standard.

Guidance note:

The most severe stresses in a circular blade root section may not necessarily occur in the flap-wise and edgewise directions.

Sensors for blade bending in the aero-elastic model are defined in a coordinate system where one axis typically is located in the rotor plane at the root, and one axis located in the direction of the aerodynamic profile along the blade. The load histories for the individual sensors may not cover the most critical loads as these may occur in other directions than those of the sensors. Post processing of the sensor histories with relevant transformation matrices for arbitrary positions on the root may be required in order to find the most critical positions and stresses.

---e-n-d---o-f---G-u-i-d-a-n-c-e---n-o-t-e---

304 A full scale static and fatigue blade test shall be carried out for all new blade designs as specified in IEC WT01 and IEC61400-23. The test loads shall be specified by the designer based on the aero-elastic calculation and the material characteristics. The test loads should not be selected as the design loads, as this would require numerous load cases and a fatigue tests running for several years.

305 Test loads shall be a transformation of design loads, including test factors, selected from the most critical limit states. The transformation shall be carried out such that SRFs are not increased. Relevant test factors are applied to account for variability in loads and strength. The specification of test loads and procedures for full scale testing are detailed in Section 5.

306 A strain analysis shall be carried out for the most severe ultimate loads found in the aero-elastic analysis. The strain analysis can be carried by linear analysis supplemented with simplified local evaluation of buckling resistance. If the local buckling analysis indicates that the effect of buckling is moderate and limited to only a few elements that do not interact, then the final strain distribution can be taken as the linear response corrected for buckling based by simplified analysis.

307 The strain analysis shall be carried out as a global buckling analysis if there is a significant influence of buckling on strain distribution when the blade is subjected to ultimate loads or if there is an interaction between buckling of neighbouring structural elements in the blade. The global buckling analysis is normally carried out as a finite element analysis.

308 The blade shall not buckle under characteristic loads. Local buckling of secondary structure may be acceptable if these secondary effects are understood. Accordingly, the strains for the fatigue analysis can be based on a linear analysis.

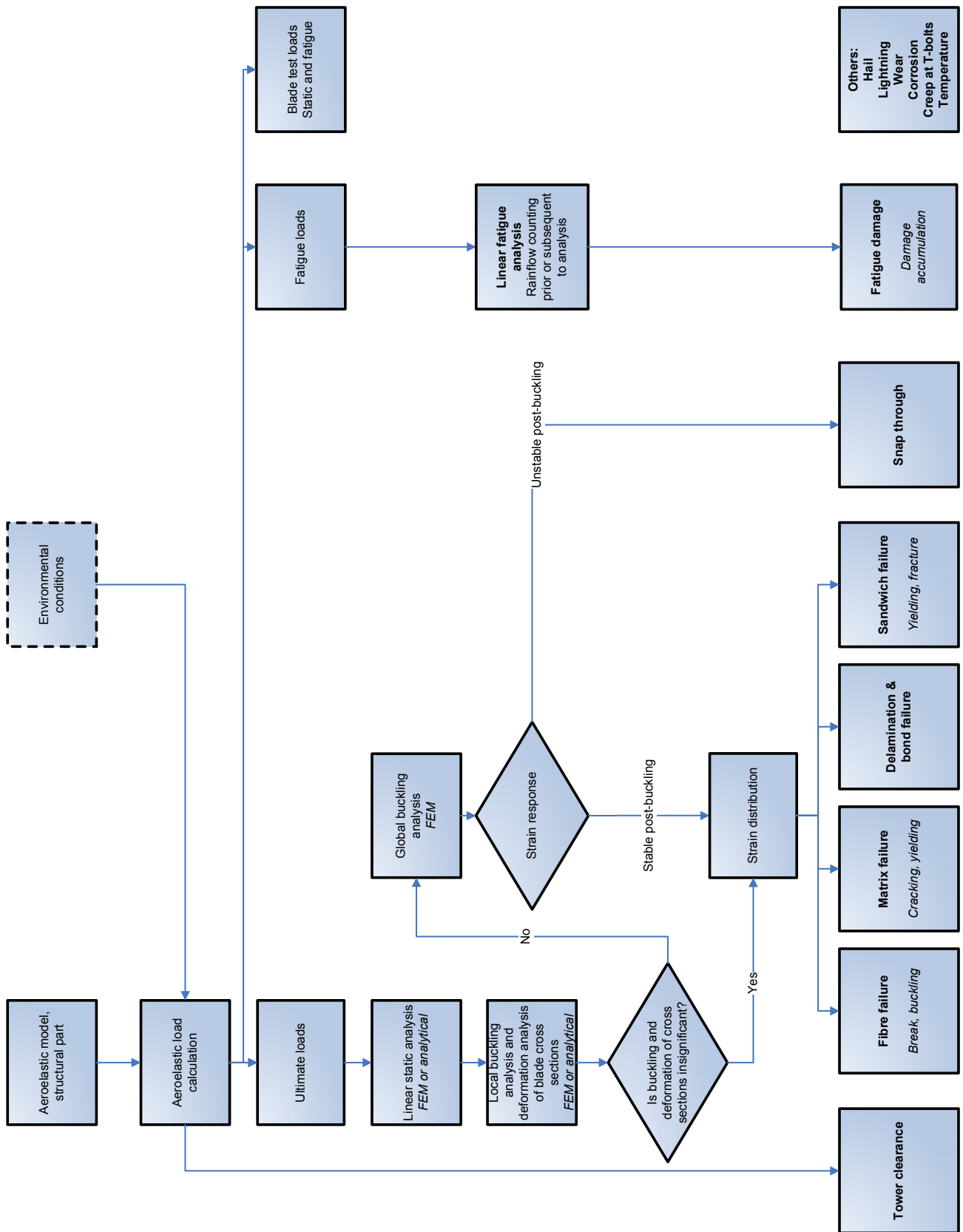

Figure 5- Processes in the analytical verification of wind turbine blade strength

A400 Composite failure modes

401 On a global level for the wind turbine blade, these failure mechanisms are caused by a combination of axial tension, axial compression, torsion and bending loads. As such, the global analysis of the wind turbine blades is to provide the worst combination of these loads for the local analyses of each failure mechanism.

402 All potential failure mechanisms for the structure shall be identified and analysed at the individual ply/lamina level. Relying only on a laminate level analysis can lead to un-conservative results and is to be avoided. The most common failure mechanisms relating to composite materials are summarised in Table 11 with the associated reference to detailed informative guidance in the appendices.

Table 11 – Typical composite failure mechanisms		
Failure Mechanism	Comments	Appendix
Global buckling	<ul style="list-style-type: none"> Global buckling of the laminate 	C
Fibre failure	<ul style="list-style-type: none"> Fibre failure with dominant strain parallel to the fibre direction (ϵ_1) exceeding the tensile or compressive strength capacity of the individual fibres. Fibres can buckle at a micro and macro levels. Buckling will reduce the compression strength drastically, with imperfections further increasing the effect of buckling. Fibres generally do not yield, experiencing brittle fracture. 	D
Matrix failure	<ul style="list-style-type: none"> Matrix failure can occur due to longitudinal/transverse tensile and compressive (σ_1, σ_2) or in-plane shear stresses (τ_{12}). Matrix failure results in degraded strength and stiffness of the laminate, and can lead to further de-lamination. Can be critical for transverse loaded UD laminates (σ_2), and in 0/90 laminae loaded in in-plane shear (τ_{12}), as well as at joint details. Yielding of the matrix material is also to be evaluated. Matrix failure analyses shall consider both the matrix and the interface to the fibre. Seizing of the fibre may have a significant impact on the interface strength. 	E
Inter-laminar failure	<ul style="list-style-type: none"> Inter-laminar shear failure occurs in the matrix between adjacent plies/ laminae due to shear stresses (τ_{xz}, τ_{yz}). Inter-laminar tension failure occurs in the matrix between adjacent plies/ laminae due to tensile stresses (σ_z). These failure modes can lead to de-lamination and sub-laminate buckling. 	F
Sandwich failure	<ul style="list-style-type: none"> Ultimate failure of the sandwich core material due to tensile, compressive, and shear loading. Local yielding of the sandwich core due to tensile, compressive, and shear loading. The sandwich interface with the laminate. Additional potential buckling failure modes for the sandwich structure of wrinkling, shear crimping, and face dimpling. 	G
Fatigue failure	<ul style="list-style-type: none"> Cyclic loading leads to the accumulation of fatigue damage, with the fatigue damage phases characterised by matrix cracking, de lamination, progressive fibre breaking, and final fracture. If it can be demonstrated that the structure can withstand the degradations inherent in the fatigue damage phases, then the fatigue failure mode can be selected as final fracture. 	H

Guidance note:

Yielding is typically a failure mechanism for polymeric foams, however most FRP laminates experience brittle fail. Yielding can be taken into consideration through:
 -The design preventing yield through material selection or limiting stresses.
 -A full nonlinear analysis carried out to considering the full effects of yielding.

---e-n-d---o-f---G-u-i-d-a-n-c-e---n-o-t-e---

403 All relevant failure mechanisms shall be globally evaluated for criticality along the blade. If a failure mechanism is found to be critical, design calculations or testing is to be carried out to demonstrate that this failure

mechanism will not occur within the design lifetime of the blade.

404 The failure mode for fatigue is the local exceedance of the fatigue life predicted by the fatigue damage accumulation model.

Guidance note:

The mechanisms of failure of FRP structure can be considered at different material levels. Failure can be considered to occur in the matrix, in the interface between the matrix and the fibre or in the fibre. On a larger scale, it can occur in the individual lamina or core. It is an option to

PROPOSAL

RP-2005-33 Rev.1

consider failure of the entire FRP structure as one entity, i.e. the entire laminate or the entire sandwich structure.

Design criteria are often investigated on the most detailed level, i.e. first ply failure is used for a criteria for laminate strength. For some structure there is a high redundancy and there may be significant conservatism in this approach.

---e-n-d---o-f---G-u-i-d-a-n-c-e---n-o-t-e---

405 In some cases, a critical sequence of failure mechanisms may be required for a particular failure mode to occur, implying a progressive development of failure. These cases shall be identified and evaluated where critical.

Guidance note:

Different sequences may lead to the same failure mode. In this case, the structure shall only be considered as failed, if the whole sequence of mechanisms of failure modes has occurred.

---e-n-d---o-f---G-u-i-d-a-n-c-e---n-o-t-e---

406 Laminates and sandwich structures typically exhibit a sequence of failure mechanisms that shall be considered. If a particular failure mechanism in the sequence cannot be sufficiently analysed, then the component shall be designed in such a way that the preceding failure mechanism can not occur.

Guidance note:

Typical failure sequences for laminates are:

- matrix cracking => de-lamination => fibre failure
- disbonding and matrix cracking => fibre buckling => fibre failure
- de-lamination => crack propagation due to fatigue => global buckling

An unusual, yet possible sequence is: Wedge shaped matrix cracks => component failure in compression

Under fatigue loading, crack initiates in the core due to core shearing => crack then propagates in core material => face-core de-lamination starts when shear crack reaches interface => face-core de-lamination propagates along the interface until final catastrophic failure.

---e-n-d---o-f---G-u-i-d-a-n-c-e---n-o-t-e---

407 The following additional failure causes shall be considered in these failure mechanisms:

- Impact damage from hail and other foreign objects
- Lightning strikes
- Erosion (wear from particulates in the air)
- Corrosion at steel and dissimilar laminate interfaces
- Creep in areas under high constant loading load (e.g. at T-bolts)
- Moisture and temperature effects.

A500 Design criteria

501 A design criterion shall be assigned to each relevant failure mechanism. General design criterion is to be based on the partial safety factor format of IEC 61400-1:

$$S_d(\gamma_f F_k) \leq \frac{R_k}{\gamma_m \gamma_n}$$

Where:

γ_f	Load factor
F_k	Characteristic load
S_d	Local stress or strain based design load effect
R_k	Characteristic resistance
γ_m	Partial safety factor for material, also known as material factor
γ_n	Consequence of failure factor

502 The design criteria must be demonstrated as being fulfilled for all critical load cases, limit states, and failure mechanisms. The fulfilment of the design criteria can be demonstrated with the use of the Safety Reserve Factor (SRF) method. The SRF can be calculated for each load case and failure mode as follows:

$$SRF = \frac{R_k}{\gamma_m \gamma_n S_d}$$

503 The design criteria is satisfied when $SRF > 1.0$. This design criteria is in principle applicable to both ultimate and fatigue limit state analysis. However, alternative formulations may be used for fatigue limit state analysis as explained in Appendix H.

A600 Partial safety factors for loads (γ_f)

601 The required limit state analysis is clearly identified in IEC 61400-1. Depending on the limit state analysis, the characteristic value of a load is defined as follows:

- -For normal loads relevant for design against the ULS the characteristic value of the load is defined as the 98% quantile in the distribution of the annual maximum load, i.e., that load with a return period of 50 years
- -For abnormal loads the characteristic value of the load is representative for the typical response of the turbine to the abnormal event.
- For loads relevant for design against the FLS the characteristic load history is defined as the expected load history.

602 Load effects shall be determined for all phases during the life of the blade, i.e. transport, installation, operation, repair. Nonlinear effects in the analysis shall be considered when obtaining the local stress or strain distribution.

PROPOSAL

RP-2005-33 Rev.1

603 Aerodynamic blade loads shall be calculated by aero elastic methods.

Guidance note:

Aerodynamic load calculations can be performed in accordance with aero elastic methods as specified in IEC61400-1 and in DNV/RISØ Guidelines for Design of Wind Turbines.

---e-n-d---o-f---G-u-i-d-a-n-c-e---n-o-t-e---

604 Table 12 specified requirements to load factors for different load types in ULS design. For further information, refer to IEC 61400-1 directly.

Unfavourable loads			Favourable loads
Type of design situation			All design situations
Normal	Abnormal	Transport and erection	
1.35 *)	1.1	1.5	0.9

*) The load factor can be reduced to 1.25 if the characteristic loads are derived based on extrapolation.

605 For FLS design a load factor $\gamma_f=1.0$ applies to all load values in the characteristic load history.

A700 Partial safety factors for consequence of failure (γ_n)

701 The consequence of failure factor is in accordance with IEC-61400-1, where the blade shall be classified as Component class 2. The consequence of failure factors are summarised at Table 13.

Factor	Limit state	
	ULS and tower clearance	FLS
γ_n	1.0	1.15

A800 Partial safety factors for materials (γ_m)

801 The value of the partial safety factor for materials accounts for the inherent variability in the characteristic material strength.

802 For FRP and laminated wood structures, the variation and environmental effects on material characteristic strength can be quite significant when compared to traditional metallic structures. To account for this variation, the material factors must be specifically developed for each material type. This can be done either through a dedicated test program, or through an empirical approach based table 14.

803 For a dedicated test program, the material properties must be developed based on enough tests of material meeting recognised specifications to establish the design values on a valid statistical basis. The test program can be developed in conjunction with ISO 2394, and should take into account as a minimum the effects of:

- Variability in the constituent materials
- Variability in the manufacturing process
- Environmental effects, such as temperature and moisture
- Effects of cyclic loading
- Local laminate details, such as ply drops

Guidance note:

Cyclic loading results in matrix-cracking in FRP materials, where at a strain before ultimate failure the matrix cracks transversely crack from the reinforcing fibres. Small micro-cracks will begin to develop in the matrix, and can result in moisture ingress and de-lamination. The onset of matrix-cracking is also accelerated through the application of cyclic loads, and is associated with the first stage of FRP fatigue. Traditionally, this phenomenon has been taken into account by using the γ_{m1} , and γ_{m3} value of Table 14 below, however a dedicated test program aimed at developing a unique material factor must take this into consideration.

---e-n-d---o-f---G-u-i-d-a-n-c-e---n-o-t-e---

804 Where a dedicated test program has not been conducted, the material factor is to be calculated by an empirical approach using the partial factors listed in Table 14.

805 The material factor γ_m is given as a product of several factors:

$$\gamma_m = \gamma_{m1} \gamma_{m2} \gamma_{m3} \gamma_{m4} \gamma_{m5} \gamma_{m6}$$

Where γ_{m1} to γ_{m6} are the partial safety factors and strength reduction factors described in Table 14.

Table 14 - Partial safety factors for materials (γ_m) for FRP, laminated wood, and adhesives			
<i>Description</i>	<i>Factor</i>	<i>Limit state</i>	
		<i>ULS</i>	<i>FLS</i>
Base material factor for material	γ_{m1}	1.3	1.2
Correction factor if strength data refer to 97.5% confidence instead of 95% confidence	γ_{m2}	0.95	0.95
Strength reduction factor for repeated loading/low cycle fatigue	γ_{m3}	1.1	-
Strength reduction factor for size effects, temperature, ageing and degradation for UV radiation and humidity: - Epoxy based resin system - Polyester, and Vinyl ester based resin system - Wood with epoxy FRP shielding	γ_{m4}		1.1 1.2 1.1
Strength reduction factor for effects of optional materials and manufacturing methods: <i>Fibre reinforced thermo setting resin</i> - Prepreg or resin infusion unidirectional plies – areas with continuous plies and no ply drops and manufacturing methods which do not allow wrinkles through laminates - Prepreg or resin infusion with mainly unidirectional plies including ply drops - Random orientated mats and/or hand lay up <i>Laminated wood, number of veneers through the thickness</i> - More than 11 veneers - 6 veneers - 4 veneers - 3 veneers or less Interpolation between these values shall be done for other number of veneers <i>Sandwich core</i> - Plastic polymeric foam, designed for yielding (PVC) - Brittle polymeric foam designed for fracture (PMI) - Balsa wood <i>Bonded joints</i> - Paste adhesives	γ_{m5}		1.0 1.1 1.2 1.0 1.1 1.2 1.3 1.0 1.1 1.3 1.3
Strength reduction factor for post curing: - Post curing controlled with DSC or equivalent - Post curing without control of cured laminate - Exothermic curing only	γ_{m6}		1.0 1.05 1.1

Guidance note:

The factors in Table 14 may be modified based on the designer's justification when provided with appropriate justification.

---e-n-d---o-f---G-u-i-d-a-n-c-e---n-o-t-e---

Guidance note:

There may be large variations in fibre content and fibre thickness in wet lay-up.

---e-n-d---o-f---G-u-i-d-a-n-c-e---n-o-t-e---

806 The design of components in metallic materials shall follow recognised standards and guidelines such as DNV Guidelines for Certification of Wind Turbine Power Plants.

A900 Geometrical Parameters

901 Nominal dimensions shall be used for all calculations related to FRP laminates or polymers except for thicknesses taken into account in buckling calculations. Thicknesses for use in buckling calculations shall be conservatively estimated as the minimum expected thickness with the selected manufacturing process.

PROPOSAL

RP-2005-33 Rev.1

B. Verification of input for design loads and tower clearance analysis

B100 General

101 The verification of input for the load and clearance analysis shall confirm the distribution of aerodynamic profiles, as well as orientation of the local coordinate systems in system model. A comparison of measured and calculated values shall be conducted for the following properties as a minimum:

- Mass.
- Mass distribution and centre of gravity.
- First and second flap-wise natural frequency and damping.
- First edgewise frequency and damping.
- Flap-wise blade tip deflections in load conditions that are representative for the load at minimum tower clearance.
- Torsional stiffness.

Guidance note:

Torsional stiffness verification can be omitted if it is justified that flutter instability is not critical for the blade design.

102 The verification of input for the load analysis shall evaluate the effect of combined design loads for all critical areas of the blade.

Guidance note:

Combined loads are normally critical in the blade root section.

C. Tower clearance

C100 General

101 The deflection of the blade shall be kept smaller than a specified upper limit in order to avoid blade contact with the tower or other components. The design criterion for deflection of the blade is given by the following inequality:

$$D_d(\gamma_f F_k) \leq \frac{D_i}{\gamma_n \cdot \gamma_m}$$

Where:

- F_k Characteristic load
- D_d Largest tip deflection when passing the tower
- D_i Smallest distance from blade tip to tower or other obstacle in the unloaded condition
- γ_f Load factor
- γ_m Material factor for stiffness
- γ_n Consequence of failure factor

Guidance note:

Normally the deflection response of the blade tip to loads on the blade is linear. If this is the case the load factor can be multiplied with a deflection response based on the characteristic load alone.

---e-n-d---o-f---G-u-i-d-a-n-c-e---n-o-t-e---

102 The deflection analysis is to model representative stiffness of the wind turbine, and therefore is to include stiffness of the hub, pitch bearing, and other associated components.

103 The material factor (γ_m) in deflection criteria (mainly tip to tower distance) shall be taken as 1.1 when mean values for stiffness is used in the analysis. The material factor may be reduced to 1.0 if:

- The deflection analysis is carefully calibrated with the full scale static testing of the blade.
- A quality control instruction covers retesting of the flap-wise stiffness for manufactured blades on a spot check basis.

D. Additional Failure modes

D100 Erosion

101 Wind turbine blades are vulnerable to erosion, in particular at the leading edge and tip. This erosion can be caused by such environmental exposure as rain, dust, and sand.

102 Relevant surface finishes shall be evaluated for expected erosion, and the basis for erosion protection is to be explicitly stated in the technical specifications for the blade.

103 If the blade utilises anti-icing functions, the surface finishes shall be evaluated against erosion for the maximum expected surface temperatures.

Guidance note:

If rubber reinforcement of the leading edge in the tip area is included in the design, this shall form part of the technical specification for the blade. The reinforcement may have an impact on noise and loads and shall be present during type testing.

---e-n-d---o-f---G-u-i-d-a-n-c-e---n-o-t-e---

D200 Environmental Protection

201 Most FRP materials are sensitive to the direct exposures to external environmental effects such as moisture, temperature, foreign chemicals, and UV light. The blade design shall ensure that structure is insulated from these effects with an adequate environmental sealing system. All external FRP machined edges and surfaces shall be sealed.

Guidance note:

Environmental sealing is usually provided through: initial coating of gel coat in the mould; or a polyurethane based paint applied after de-moulding.

---e-n-d---o-f---G-u-i-d-a-n-c-e---n-o-t-e---

202 All insulating surface finishing products shall be designed to insulate the FRP material from the environment for the service life of the wind turbine.

203 Materials shall be selected that do not decompose chemically in the expected environment during the design lifetime. If this cannot be avoided, these effects shall be

PROPOSAL

RP-2005-33 Rev.1

quantified and allowed for in the development of the material's characteristic strength.

204 The inadvertent exposure of materials to chemicals (such as hydraulic fluid) during maintenance activities shall also be considered. If the exposure is considered significant, its effects shall be allowed for in the development of characteristic strength (R_k).

Guidance note:

Sensitivity tests for exposed laminates should be based on ASTM D53793 shear strength, with the laminate soaked in the subject fluid for a minimum of 60 – 90 minutes for meaningful test results. Shear strength will provide the best indication of sensitivity to chemical exposure for a laminate.

---e-n-d---o-f---G-u-i-d-a-n-c-e---n-o-t-e---

205 Some core materials can also release gases over time, especially under high temperatures. The pressure build-up from these gases can cause core/skin delamination. Only cores that are properly degassed shall be used in production.

206 Corrosion of the constituent materials shall also be considered. CFRP in contact with metals other than titanium can lead to galvanic corrosion and shall always be insulated.

207 To prevent water accumulation in the blade, the design shall incorporate a drainage system.

D300 Lightning

301 Wind turbine blades shall be designed against lightning strikes through the installation of a lightning protection system. The lightning protection system shall be designed for the requirements of IEC 61400-24.

302 Blades that are designed with CFRP reinforcement shall be protected under due consideration of the electrical conductivity of the CFRP. This can be done either by integrating the CFRP in the lightning protection system or by protecting the CFRP with a conductive mesh in the blade laminate.

303 Metallic parts in the blade structure away from the root and the lightning protection system shall be avoided where possible.

Guidance notes:

Thermo sensors and probes used in the blade laminate during manufacture should be removed after manufacture, as this will create local lightning paths.

---e-n-d---o-f---G-u-i-d-a-n-c-e---n-o-t-e---

D400 Impact damage

401 Wind turbine blades are vulnerable to impact damage from rain, hail, and foreign objects during operation. Accidental impacts (e.g., during transport and servicing) are also to be considered.

Guidance notes:

Accidental impact should lead to visible damage if it is critical for the strength of the blade. Otherwise the blade shall be designed for a maximum impact determined based on the packaging, transport and installation procedures.

---e-n-d---o-f---G-u-i-d-a-n-c-e---n-o-t-e---

402 It is to be shown that impact damage that can be realistically expected from manufacturing, transport,

installation, and operation will not reduce the design resistance strength below the design load.

403 This can be shown by analysis supported by test evidence, or by tests at the coupon, element or subcomponent level. Further guidance is provided at Appendix I.

D500 Creep

501 The effects of possible creep or strain relaxation on the wind turbine blade system shall be evaluated.

Guidance note:

Creep is typically critical for pre-stressed T-bolt joints in the blade root.

---e-n-d---o-f---G-u-i-d-a-n-c-e---n-o-t-e---

D600 Extreme temperatures in the blade

601 Calculation of extreme temperatures shall cover the specified maximum expected ambient temperatures and solar radiation for the expected operating environment during storage, transport, and operating conditions.

602 Typical daily variations in ambient temperatures and solar radiation may be used together with data for heat capacity to find the maximum daily temperature. All blade colours specified in the blade's technical specification shall be considered.

Guidance note:

The extent of the verification of extreme temperatures may be limited if the extreme temperature has little impact on the properties for the materials used. Temperature has a large effect on the structural properties of FRP materials, and should always be considered.

The mechanical properties change rapidly with temperature near the glass transition temperature of polymeric materials. Thermosetting polymers like polyester, vinyl esters and epoxies are applied to service below the glass transition temperature. Normally, the mechanical properties of thermosetting polymers are insensitive to temperature when the temperature is more than 20 K below the Glass transition temperature.

The glass transition temperature of thermosetting polymers is sensitive to the temperature history during curing as well as moisture. The glass transition temperature can be measured by several different methods.

The value of the glass transition temperature will depend on the measurement method as well as the amount of plasticizers in the polymer. Moisture absorbed in the polymer is to be considered as a plasticizer.

---e-n-d---o-f---G-u-i-d-a-n-c-e---n-o-t-e---

603 The materials shall not change stiffness or strength to values outside the basis for design. The strength reduction factor γ_{m4} proposed in Table 13 applies for strength and stiffness values that are not changed by temperature by more than 5% compared to the values used as basis for design. Reference is also made to Sec. 2 A 100.

PROPOSAL

RP-2005-33 Rev.1

D700 Substantiation of Repair

701 When repair procedures are provided in the manufacturer's maintenance manual, it is to be demonstrated by analysis and/or test that the detailed

methods and techniques of repair will ensure a SRF of greater than 1 for ULS and FLS analysis.

SECTION 4 BLADE MANUFACTURING PROCEDURES

A. General

102 Typical critical processes during blade manufacture are listed below in Table 15.

A100 Manufacturing procedure manuals

101 The manufacturing procedure manual shall list all critical processes with their corresponding process control procedures. These procedures should be supplemented with detailed photographs. Typical repairs may also be considered as critical processes.

Table 15 - Critical blade manufacturing processes			
Physical characteristics	Critical for	Typical means of process control and/or quality control	Notes
Adhesion of surface painting	Surface preparation	<ul style="list-style-type: none"> •Adhesion tests to be applied as quality control. 	
Air entrapment in resins or adhesive	Strength	<ul style="list-style-type: none"> •Rolling consolidation during wet hand lay up. •Quarantine of mould enclosure prior to resin infusion. •Mixing process should not trap air in the resins or adhesives. •Use of degassed core materials. 	<ul style="list-style-type: none"> •Sandwich materials can degas when heated, which must be allowed for.
Bad bonding to metallic bushings	Bond strength	<ul style="list-style-type: none"> •Cleaning of metal bushings with solvent prior to bonding. •Priming of metal parts. 	
Balancing of static moment at root for a blade set	Rotor imbalance will lead to vibrations and fatigue	<ul style="list-style-type: none"> •Adding of weight to the lightest two blades. 	
Condensation on materials	Strength	<ul style="list-style-type: none"> •Condensation can be avoided if the temperature in the workshop is a few °C higher than in the storage facility. •The materials shall be brought to the work shop in due time to allow them to adjust to the local work shop temperature. 	<ul style="list-style-type: none"> •A suitable means of transport is required where the storage facility is physically separated from the work shop.
Correct lay-up of sandwich core material	Wrinkles in laminate & Buckling strength	<ul style="list-style-type: none"> •Colour codes & visual inspection. 	<ul style="list-style-type: none"> •Visual inspection shall be carried out by a foreman or a representative from the manufacturer's quality department.
Correct type and location of plies	Laminate strength	<ul style="list-style-type: none"> •Clear and comprehensive kitting procedures. •Colour codes and clear working instructions. 	
Curing of resins and adhesives	Strength Permanent deformation of the blade	<ul style="list-style-type: none"> •Control of pot life and processing times. •Cure cycle temperatures recording during processing, with thermo-graphic or thermo sensors. •Barcol hardness tests carried out post cure. •Time or hardness requirements to be specified as a condition for the break out of the cured part from the mould. •Post curing at elevated temperature or cold post curing shall be specified. •Test of cured samples, e.g. by crushing 	<ul style="list-style-type: none"> •Thin and thick laminate may have different curing histories due to exothermic behaviour of resin during the curing. •The blade may permanently deform if it is released from the mould too early.
Degradation of gel coats, resins or adhesives	Strength	<ul style="list-style-type: none"> •Control of temperature, dust and sunlight in the facility. •Temperature and humidity data to be measured, and controlled. •Expiry dates shall be clearly indicated on the materials. 	<ul style="list-style-type: none"> •The acceptable storage temperatures shall be taken in accordance with the supplier data sheet. This is particularly important for preregs. •Excess dust can be avoided by always storing materials in their relevant containers, or packaging when not in use. •Unused materials shall not be returned to the ware house unless there is a specific procedure to control this.
Dry areas in laminate surface	Surface finish	<ul style="list-style-type: none"> •Process control, and detailed work instructions during lay up (wet only). 	<ul style="list-style-type: none"> •Common with wet hand lay up of polyester FRP.
Dust and moisture in reinforcing fibres	Strength	<ul style="list-style-type: none"> •Control of dust, temperature and humidity in the warehouse for reinforcing fibre storage. •Temperature and humidity data to be measured, and controlled. 	<ul style="list-style-type: none"> •The fibres should preferably be stored at a temperature which is 2 °C higher than the temperature in workshop. •The daily variation in temperature in the mould should be within ±3 °C. •The humidity in the work shop shall be

			lower than 80%.
Flatness of root	Has an impact on the fatigue of bolts in root joint	•Grinding of root	
Flaws in adhesive joints	Bond strength	•Careful control of applied volume of adhesive, and joining of parts. •Thermo graphic inspection of blade during curing of adhesive.	
Gel coat blistering	Noise and aerodynamic properties	•Control of resin mixing ratio.	•Gel coat blistering is usually caused by incomplete resin polymerisation, attributed to either too little or improper mixing of the catalyst.
Gel coat thickness	Erosion resistance and strength	•Special comb for thickness control during rolling	•The gel coat thickness should typically be between 0.3 and 0.6 mm
Gel coat to laminate bonding	Bond strength	•Control of the elapsed time before the gel-coat is covered with a laminate. •Use of a thin ply of fibre reinforcement. •Tap testing post cure for disbonds.	•The wetted laminate should be applied to the mould within 12 hours of initial gel coat application.
Loose adhesive	Noise		
Mixing of adhesives and resins	Strength	•Calibrated automatic mixing machines shall be used. •Defined mixing ratios for hardener and accelerator.	•Cured strength is typically more sensitive to the mixing ratio for epoxies rather than polyesters.
Pinholes in blade surface	Noise and aerodynamic properties	•Control of vacuum pressure during cure cycle.	•Holes can be filled with primer/filler. •Gel coat can be utilised in the surface finish design.
Relative dislocation of suction and pressure side of a bonded blade	Aerodynamic properties	•The mould closing mechanism shall prevent this kind of defects.	
Repair of laminate	Strength	•Tapering of layers in the bond at the edge of the repair.	
Sealing of materials sensitive to moisture	Degradation of materials due to moisture, fungus, or rot	•Sealing or painting	•May be critical for wood surfaces, for edges of machined laminate, and for sandwich core materials near lightning receptors. •Sealing of surfaces may require a fibre reinforcement of the coating.
Surface preparation for bonding	Bond strength	•Grinding of peel ply. •Parts to be joined shall normally be fully cured.	•Grinding is required in case of a laminating process that has been interrupted
The edgewise angle between the root plane and direction from the root centre to mass centre for the blade	Variations for a blade set contribute to rotor imbalance		
The flap-wise angle between the root plane and direction from the root centre to the tip	A narrow tolerance is required if the tip to tower distance is critical for a turbine		
Thickness of adhesive joints	Bond strength	•Measurement of bond thickness before applying adhesive. •Use of adhesives with bond thickness control additives such as micro-balloons.	•Bond thickness can also be controlled through the use of film adhesives.
Thickness of trailing edge in the outer part of the blade	Noise	•Grinding with subsequent repair of laminates, bonded joints and gel-coat.	•Grinding can damage the blade.
Too much adhesive	Total weight of blade	•Final blade weight measurement.	
Twist of blade	Aerodynamics of rotor	•Rotor blade sets to be made from the same mould.	
Wrinkles in laminate	Laminate strength	•Stretching of plies during lay-up. •Fixing of plies with clamps etc.	•Stretching can be difficult when the mould surface is not horizontal. •Visual inspection shall be carried out by a foreman or a representative from the manufacturer's quality department.
Wrong combination of materials	Strength	•The materials required for a manufacturing process shall be documented and controlled. •The quantity and condition of required materials shall be verified against the requirements of the manufacturing process.	•Uncontrolled combinations of materials occur if these are running short during the manufacturing process.

SECTION 5 BLADE TESTING

A. General

A100 General

101 All new blade designs shall be tested. The objective of the blade test is to verify the structural properties of the blade such as:

- Mass and centre of gravity.
- Stiffness distribution.
- Natural frequency and damping.
- Ultimate strength.
- Fatigue strength.

102 Test loads are normally applied as concentrated loads and primarily to test the global bending strength of the blade. Local strength of panels subject to the load from air pressure and from the global deformation of the blade may have to be tested in addition to the global bending strength depending on the reserve factors in the design for such panels.

103 It is not necessary to test parts where the structural reserve factors have been verified to be sufficiently large through numerical calculations; or where the layout and loading is representative of similar parts that have been previously tested.

Guidance note:

The judgement of ‘sufficiently large’ reserve factors is the responsibility of the designer, and requires justification if testing is to be omitted.

For example, wind turbine blade tips are often tested at reduced levels due to testing constraints. This is typically justified due to ‘sufficiently large’ reserve factors in this area.

---e-n-d---o-f---G-u-i-d-a-n-c-e---n-o-t-e---

104 Test loads shall be taken in accordance with IEC 61400-23. The specification of test loads shall take into consideration the test blade selected, the SRF derived from analysis, and the variation in the structural layout of the blade along the blade’s axis.

Guidance note:

The fundamental purpose of full scale blade testing is to demonstrate, to a reasonable level of certainty, that a blade type when manufactured according to defined specifications possesses the strength and life as expected in the design.

Full scale blade tests are carried out on typically one prototype blade.

---e-n-d---o-f---G-u-i-d-a-n-c-e---n-o-t-e---

105 Test loads are primarily applied to test the global bending strength of the blade. Local strength of panels may have to be tested in addition to the global bending strength depending on the reserve factors in the design for local load distribution.

106 The stiffness of the test rig may have an influence on the natural frequencies and deflections measured. The stiffness of the test rig shall be measure and reported. . This is of particular significance if the test rig is flexible or a bearing is inserted between the test rig and the blade.

B. Selection of test blade and specification of testing

B100 Selection of test blade

101 Testing of blades shall be carried out for all blade types and in case of major changes in design or in the substitution of materials that significantly change the properties.

Guidance note:

Large adhesive joints shall normally be retested in case of changes in the adhesives or the surfaces to be joined.

---e-n-d---o-f---G-u-i-d-a-n-c-e---n-o-t-e---

102 A test blade can be selected according to one of the following three criteria:

- The first blade produced.
- Random sampling of a blade among all blades produced.
- As a worse case based on recorded manufacturing history and NDT.

103 If the first produced blade is selected for testing, then the manufacturing history must be thoroughly documented and the manufacturing process be witnessed by an independent third party unless otherwise agreed with the certifying body.

Guidance note:

There is typically a change in process history from the first blade produced to the later blades in the production. Such changes must be recorded even if the work instruction is not complete at the time of manufacturing of the test blade. Photos, films and log-books may be used to supplement preliminary work instructions.

---e-n-d---o-f---G-u-i-d-a-n-c-e---n-o-t-e---

104 If the test blade is selected on a random basis the manufacturing shall normally not be witnessed by an independent third party.

105 If a worst case blade is identified and tested then the test factors γ_{su} and γ_{sf} for blade to blade variation can be reduced. The method used to rank the blades must be part of the quality control instructions and refer to defects and imperfections that are controlling the particular capacity investigated in the test. The inspection used to rank the blades shall be witnessed by an independent third party unless otherwise agreed with the certifying body.

Guidance note:

For example, if the blade is produced with the worst case level of manufacturing defects (i.e., artificially included damages) that can be reasonably expected during manufacture (with reference to the manufacturing quality system), then these blade to blade variation factors may be reduced to 1.0.

---e-n-d---o-f---G-u-i-d-a-n-c-e---n-o-t-e---

106 The as-built documentation for the test blade is to be prepared in accordance with Section 6.

PROPOSAL

RP-2005-33 Rev.1

B200 Parts of the blade to be tested

201 The test should cover as many parts and areas of the blade as possible.

202 Blade tip brakes shall be tested for extreme loads, fatigue, as well as wear from repeated brake applications.

Guidance note:

The blade bearing and hub should preferably be integrated in the tests. If they are not integrated, then their effects on the results are to be considered.

---e-n-d---o-f---G-u-i-d-a-n-c-e---n-o-t-e---

B300 Natural frequencies and damping determination

301 Natural frequencies and structural damping shall be determined. As a minimum, the following natural frequencies shall be determined:

- 1st flap-wise
- 2nd flap-wise
- 1st edgewise
- 1st torsional

302 As a minimum, the structural damping shall be determined for the following natural frequencies:

- 1st flap-wise
- 1st edgewise

303 Aerodynamic damping contributes to the results of the measurements of damping, as the measured result is a combination of both aerodynamic and structural damping. The contribution from aerodynamic damping is highest when determining the damping in the flap-wise direction. It is therefore important to measure the structural damping with very small blade deflections. The maximum acceptable deflection of the blade tip depends on both the natural frequency and velocity of the blade; the blade response over a set period of time is to be evaluated to determine the maximum acceptable blade tip deflection.

304 The temperature of the blade will influence the natural frequencies and the damping. It is therefore important to know the temperature of the blade when natural frequencies and structural damping are determined. This can be achieved by letting the blade obtain the known ambient temperature inside the test laboratory before the test is carried out.

Guidance note:

The determination of natural frequencies and structural damping is normally achieved by the following approach:

The vibration mode that is subject to investigation is manually excited, with the blade response measured by an accelerometer mounted at the blade tip. The accelerometer output is then analysed by computer or manually after plotting the signal.

The natural frequency in torsion can be determined by the same method; however the accelerometers are fitted at both the leading and trailing edge of the blade to measure the torsional response.

Alternatively, the natural frequencies and the structural damping can also be evaluated by modal analysis, which also allows determination of the mode shape. Modal analysis is

recommended for verification of the input parameters of the aero elastic codes used during load calculation. Modal analysis can be carried out by the following approach:

A hammer with a force transducer mounted to it excites the blade, with the responses measured by accelerometers distributed at approximately 10 different positions along the blade. The response function between the force transducer and the accelerometers can then be determined by Fourier Form Transfer (FFT) analysis. Experimental results will consist of natural frequencies, damping coefficients, and modal shapes for several harmonics.

---e-n-d---o-f---G-u-i-d-a-n-c-e---n-o-t-e---

B400 Static testing

401 The applied test load is greater than the design load to account for influences from temperature, humidity, production (blade to blade variations) and other environmental aspects during the life of the blade. The test load is determined as:

$$\text{Test load} = \gamma_{su} \gamma_f F_k$$

Where:

γ_{su} is the blade to blade variation factor

$\gamma_f F_k$ is the design load from Section 3

402 The blade to blade variation factor γ_{su} is normally taken as 1.1, however may be taken below 1.1 when a worst case blade is used for testing.

403 Static testing shall be conducted with a full indicative structural representation of the blade design; it is not acceptable to test only those parts thought to have the greatest strains. The static test must test all extreme load cases in each of the 5 directions as follows:

- Flap-wise direction from suction side to pressure side.
- Flap-wise direction from pressure side to suction side.
- In edgewise direction from trailing edge towards leading edge.
- In edgewise direction from leading edge towards trailing edge.
- In torsion only the stiffness distribution is determined, this test may be omitted if the torsional stiffness is not critical for the blade design.

404 Load application usually consists of fitting one or more load clamps to the blade, and then pulling these load clamps in either the vertical or horizontal direction with a tensioning wire. Multiple load application in several positions simultaneously provides a more representative load distribution of both bending and shear. However, multiple load application will contribute to the static stability of the blade which must be taken into consideration. The widths of the clamps are to be as small as possible taking the surface pressure into account. When loading in the horizontal direction, disturbances from the weight of the blade itself and the various load clamps will not affect the test.

Guidance note:

The load clamps for a tensioning wire shall align with the neutral axis of the blade to reduce moment coupling bending loads are applied. Second order effects are important to consider for tensioning wires near the tip of the blade, as blade tip deflections can be in the order of 20 % of the blade length.

---e-n-d---o-f---G-u-i-d-a-n-c-e---n-o-t-e---

405 The deflection of the blade in the flap-wise direction can be very large, and consequently the moment arm of the load application point will vary during the test. In order to avoid gross testing errors, this change in moment arm distance must be allowed for when calculating the applied bending moment.

406 Edgewise and flap-wise bending loads are normally not applied as a combined test load. For some parts of the blade, in particular at the root, extreme flap-wise or edgewise test loads may be increased to compensate for combined edgewise and flap-wise load effects.

407 At the required test load, the load must be maintained for a period of time to allow for load settling. As a minimum this period of time must be greater than the extreme load duration experienced by the wind turbine in operation, as well as allowing for inspection of the blade, In lieu of a specified period of duration, a default period of 10 s is recommended.

408 All strains shall be measured at critical locations and directions. Strains shall at least be measured longitudinally in the leading edge, the trailing edge and on each side for every second meter.

409 Deflections shall be measured at the tip and at the middle of the blade. The location of anchor points for the deflection measurements shall be described such that second order effects can be identified and allowed for. The stiffness and deflection of the test rig and its influence on the test results shall be compensated for.

410 During the test the following data shall be recorded at either specified intervals or continuously:

- Strain in heavily loaded areas and areas with imperfections.
- Deflection at the tip and at an appropriate number of positions along the blade.
- Observed buckling.
- Position, angle of attack and load at all load clamps.
- Temperature.
- Descriptive photos of the test.

411 At the end of the static test a detailed inspection of the blade shall be carried out. All non-reversible changes shall be reported.

412 The consequences of the non-reversible changes have to be evaluated against the design assumptions results of this inspection. The conclusions of the evaluation

and the measured test data provide the basis for acceptance.

The criteria of Table 16 can be used as a guide in the evaluation.

Table 16 - Static test assessment criteria	
<i>Non-Critical Items</i>	<i>Critical Items</i>
Unidentified noises during the test	Total breakdown of the blade
Cracks in the gel coat	Severe damage of load carrying laminates
Cracks in the adhesive not affecting load carrying strength	Severe buckling in load carrying laminates which do not return to original shape after unloading
Cracks and damage in the area of the load clamps that appear to be caused by local effects (for example shear stress, and point loads)	Any buckling at loads coming from load cases in normal operation. This could for example be a situation with a sudden change of wind direction at cut out wind speed

B500 Fatigue testing

501 Fatigue testing can be carried out in numerous ways, with the most common methods being:

- Excitation of the blade at its natural frequency by means of a rotating unbalanced mass fixed to the blade. Through control of the rotating mass, it is possible to load a major part of the blade to its design load.
- Forced deflection of the blade by means of hydraulic activation or a similar approach. As this method requires large volume hydraulic systems it is difficult to carry out the test at high frequencies. Only part of the blade will be loaded to its design value when applying the load in one position only; however the applied loads are determined more accurately.

502 In order to apply the correct load distribution during the fatigue test it is often necessary to apply dead weights to the blade. Especially when using natural frequency excitation it is possible to apply a representative load distribution through the application of two or three dead weights. Fatigue tests in the edgewise direction combined with a static load in flap-wise direction can also be made in this way.

503 The entire blade is to be tested to the design load multiplied by a test factor according to IEC 61400-23. The test load shall then be calculated as:

$$F_{test} = F_{equivalent} \times \gamma_{nf} \times \gamma_{sf} \times \gamma_{ef}$$

Where:

PROPOSAL

RP-2005-33 Rev.1

- F_{test} is the applied fatigue test load
- $F_{equivalent}$ is an equivalent load whose associated fatigue damage is equal to the fatigue damage calculated from the design load spectrum. The equivalent load is dependent on the number of test load cycles.
- γ_{nf} is the factor for consequences of failure, taken as 1.15.
- γ_{sf} is the blade-to-blade variation factor which is normally to be equal to 1.1. This factor may be increased or decreased from 1.1 depending on the blade production method or failure probability distribution data available. Such reductions have to be evaluated on a case by case basis.
- γ_{ef} is a factor compensating for possible errors in the fatigue formulation, taken as 1.05.

504 The fatigue test loads shall be developed from the design spectrum.

Guidance note:

The procedure for the calculation of equivalent loads shall be based on a numerical model for fatigue damage calculation in the blade material for the main load carrying structure. One recognised procedure is through the use of rain-flow counting and Palmgren-Miners rule. The model shall consider the effect of mean stress on the fatigue life. This typically results in a discrete number of constant amplitude test cycles.

---e-n-d---o-f---G-u-i-d-a-n-c-e---n-o-t-e---

505 The following issues shall be considered when developing the blade fatigue test plan:

- The increase in load which is required to accelerate the test depends on the slope of the S-N diagram for the details tested. The slope of the S-N diagram (m) may vary significantly for different materials, load directions, and mean stresses. Due to these variations, some areas of the blade may not be sufficiently tested, and should be tested independently.
- To provide a comprehensive blade fatigue test, a test series involving more than one applied fatigue test load should be applied.
- The fatigue loads shall not exceed the extreme static test loads.
- The fatigue damage model used for the calculation of equivalent loads must be verified with a sufficient number of tests approved by the certifying body. These tests shall be conducted on representative specimens within the range of mean strains and strain ranges considered for the blade in the transformation from the design load spectrum to equivalent load.
- The tip of the blade can in some cases be removed to increase the natural frequency – reducing the number of load cycles required for the test. The tip shall only be removed after the initial static testing, with the tip being thoroughly inspected (e.g. by cutting and visual inspection) to detect any manufacturing defects that

may impact on the fatigue strength. Further criteria for removing the blade tip can be found in IEC61400-23.

506 The load must be applied either in the tip chord direction or perpendicular to this direction. During testing the following quantities must be recorded either at specified intervals or continuously:

- Strain in critical areas.
- Applied loads.
- Number of cycles.
- Temperature in the testing facility.
- Additional photos of test setup, and key events.

Guidance note:

The measurement of strain during the test is mainly carried out to ensure that the correct load distribution is applied during the test.

---e-n-d---o-f---G-u-i-d-a-n-c-e---n-o-t-e---

507 The fatigue test set-up shall be calibrated at periodical intervals during the fatigue test. During this calibration the stiffness and strain as function of the bending moment is checked. If no other intervals are specified the following calibration intervals may be used:

- before start
- at 10,000 load cycles
- at 50,000 load cycles
- at 100,000 load cycles
- at 250,000 load cycles
- at 500,000 load cycles
- at each 1,000,000 load cycles hereafter
- at test completion

Guidance note:

It is recommended that, in agreement with the blade manufacturer, the test laboratory keeps the certifying body informed of the results from the fatigue test during the test period.

---e-n-d---o-f---G-u-i-d-a-n-c-e---n-o-t-e---

508 During and after the fatigue test a detailed inspection of the blade shall be carried out. All non-reversible changes to the blade shall be reported.

509 The consequences of the non-reversible changes have to be evaluated against the design assumptions

510 The criteria in Table 17 can be used as a guide during the assessment of the blade:

Table 17 - Fatigue test assessment criteria

<i>Non-Critical Items</i>	<i>Critical Items</i>
Unidentified noises during the test	Total breakdown of the blade
Cracking in gel coat, filler	Severe damage of load carrying laminates and adhesive connections
Cracks in the adhesive not affecting load carrying strength	
Cracks and damage in the area of the load clamps that appear to be caused by local effects (for example shear stress, and point loads)	

Guidance note:

It is recommended that the planned examination be carried out after agreement with the certifying body.

---e-n-d---o-f---G-u-i-d-a-n-c-e---n-o-t-e---

B600 Final static testing

601 At completion of the fatigue test a final static test is to be carried out, with the objective being to verify that the blade still has the residual strength to withstand the extreme design loads. For example, possible de-lamination introduced through fatigue loading will give a far lower buckling strength than without necessarily affecting the stiffness of the blade.

602 The final static test shall be carried out under the same requirements as that of the original static test. If part of the blade (such as the blade tip) had been removed for the fatigue test, then this part shall not be included in the final static test.

603 During the static and fatigue tests some areas of the blade may experience overloading and damage that results in further damage during final static testing. In this case, the certifying body shall assess the acceptability of these damages.

Guidance note:

To facilitate examination of the blade after the final static test, it is recommended that the blade is destructively sectioned in critical areas.

---e-n-d---o-f---G-u-i-d-a-n-c-e---n-o-t-e---

B700 Other tests

701 Special additional tests may also be necessary, (such as for tip brake wear and fatigue). For additional

tests, the test method, assumptions, and acceptance criteria shall be documented.

C. Quality management of testing

C100 General

101 Tests shall be supervised according to ISO 17025. The test procedures shall specify

- Equipment: traceability of tested items, sensors and equipment. Calibration and accuracy of sensors.
- Personnel: training and responsibilities of the individuals participating in the test.
- Reporting: Accuracy, clarity and unambiguousness of reporting. Measurement uncertainties.

102 All tests shall be carried out by laboratories which are accredited according to ISO 17025. Otherwise the tests shall be witnessed by an independent third party. The third party witnessing the tests shall also approve the test report.

PROPOSAL

RP-2005-33 Rev.1

D. Reporting**D100 General**

101 Reporting of the tests shall be prepared in accordance with IEC 61400-23 and shall include as a minimum:

- Mass and location of centre of gravity and the condition of fluid dampers and tip brakes for each test blade.
- Stiffness of test rig (angular deflection at extreme loads).
- Temperature in the laboratory during the test and if the blade has been exposed to sunlight.
- Temperatures in the blade (Thermography can be used to illustrate fatigue tests).
- Natural frequency and damping for the following modes: first edgewise mode and first and second flap-wise modes.
- Torsional stiffness measurements.

- Static testing of all critical sections. Both extreme positive and extreme negative loads. Strains and deflections.
- Fatigue testing of all critical sections, Strains and deflections, preloading from exciter and masses fastened to the blade.
- Testing to verify the integrity after the fatigue test – normally a repetition of the static test.
- Noise, cracks, de-lamination, buckling, permanent deflections or other failure and damage observed during the tests.
- Any deviations from the test plan.
- Repairs carried out during the test.

102 The location of load clamps for applied loads shall be described such that the exact bending mode including second order effects are identified.

103 The equipment number for all measurement equipment shall be included in the report.

SECTION 6 DOCUMENTATION REQUIREMENTS

A. General

A100 General

101 To provide control of the design, the blade's technical requirements shall be thoroughly documented. Minimum requirements for the wind turbine blade's technical documentation will be provided.

A200 Design Documents

201 The design documents shall cover design calculations according to the limit states and design methods defined in the design procedure manual. The design loads used for calculation shall be clearly defined and separate load reports and load specifications shall be clearly referenced in the design documentation.

202 The design documentation shall include a comparison of the selected analysis model with actual test results for full scale and/or component tests including non-reversible changes to the blade during the test.

A300 Technical Documents

301 The technical documents shall cover technical specifications for blades including the following details:

- Service life
- Temperature interval, stand still.
- Temperature interval, operation.
- Mass and mass distribution, including tolerances.
- Static moment for each blade in a set of blades including tolerances.
- Chord length and thickness distribution.
- Stiffness distribution edgewise, flap-wise and torsional.
- Aerodynamic profiles – type and distribution including tolerances.
- Twist distribution including tolerances and root marking.
- Specification of wear tapes, stall strips, vortex generators and other aerodynamic devices.
- Specification of tip brake if relevant.
- Natural frequencies and structural damping (first and second flap-wise, first edgewise).
- Specification of root joint including bolt circle diameter, bolt size, number of bolts, tolerances on location of bolt holes, flatness of root and necessary constraints on hub and pitch bearing design to avoid overloading of the joint in bending.
- Specification of lightning protection level (ref. IEC 61400-24 or DEFU Recommendation 25).
- Marking of blade with manufacturer's name, blade type, and production number for the blade and blade

set, blade weight and centre of gravity, and lifting points.

- Colour and reflection (RAL, ISO 2813).
- Verified resistance to hydraulic oils.
- Verified resistance to wear from particles in the air.
- Identification of replaceable wear parts.

A400 Work Instructions and Drawings

401 Work instructions and design drawings shall include the following details:

- Drawings with the dimensions and materials for all parts.
- Work instructions for lay-up of the individual plies for the individual laminated parts of the blade parts including tolerances.
- Work instructions for adhesive joints.
- Work instructions for curing process including temperature tolerances.
- Work instructions for balancing, root and surface dressing.
- Quality control instructions and record sheets including applicable tolerances for the critical processes.
- Details of lightning protection system.
- Details of aerodynamic devices such as stall strips and vortex generators.
- Details of fluid dampers.

A500 Test Documents

501 The test specification must be based on the design loads, and test load factors specified in IEC 61400-23.

502 The test report must as a minimum include the following information:

- Development of the test loads, including a clear reference to the design loads.
- The method used to select the test blade.
- Blade total mass and centre of gravity.
- Condition of any fluid dampers and tip brakes installed for each test blade.
- Stiffness of test rig (angular deflection at extreme loads).
- Temperature at the laboratory during the test, and whether the blade was exposed to direct sunlight.
- Temperatures in the blade (Thermography can be used to illustrate fatigue testing).
- Natural frequency and damping for the following modes: first edgewise mode; and first and second flap-wise modes.
- Torsional stiffness (if critical for the design).

PROPOSAL

RP-2005-33 Rev.1

- Static testing of all critical sections at both extreme positive and negative load cases.
- Fatigue testing of all critical sections.
- Any testing conducted after the fatigue test to verify static strength – normally a repetition of the static test.
- Any noise, cracks, de-lamination, buckling, permanent deflections and other possible non-reversible changes to the blade observed during the tests.
- Engineering evaluation of the observed strains, deflections, and any permanent deformations
- Any deviations from the test plan.
- Any repairs carried out during the test.

Guidance note:

Torsional stiffness measurement can be omitted if it is justified that flutter instability is not critical for the blade design.

---e-n-d---o-f---G-u-i-d-a-n-c-e---n-o-t-e---

503 The manufacturing specification for the test blade shall be documented in an as-built condition. The documentation shall include reference to:

- Blade type (name) and production number (id).
- Revision of work instructions and drawings used during manufacturing.
- Type and batch number for all materials where traceability is required.
- Identification of worker teams responsible for each individual operation.

- Registrations used as basis for quality control.
- Repairs carried out during or after the manufacture.

A600 Installation and Service Documents

601 Installation and service manuals shall include instructions for:

- Transportation and storage procedures.
- Lifting procedures.
- Fitting requirements and tolerances.
- Pretension torque requirements for bolted joints.
- Procedures for commissioning.
- Inspection and Maintenance. Maintenance manuals developed by manufacturers are to include appropriate inspection, maintenance and repair procedures for the wind turbine blade.
- Maintenance periods for blade cleaning, and other maintenance activities.
- Procedures for surface finish repair.
- Procedures for inspection and repair following lightning strikes.

Guidance note:

Dirty blades can be critical for power production.

---e-n-d---o-f---G-u-i-d-a-n-c-e---n-o-t-e---

602 Installation and service manuals shall clearly explain which types of defects can be repaired by the owner and which types of defects require repair in cooperation with the manufacturer.

SECTION 7 BLADE MANUFACTURE

A. General

A100 General

101 The manufacture of wind turbine blades shall be carried out according to approved work instructions, quality procedures and drawings. Work instruction and quality procedures for the individual blades shall be prepared in accordance with the manufacturing procedure manual described in Section 4.

102 Quality procedures for blade manufacturing shall clearly specify the duties and responsibilities of the production department, and the quality control department, as well as qualification and training requirements.

103 Blade quality recording shall be carried out on using controlled systems. Blade quality records shall cover the following items:

- Revision numbers of drawings and work instructions used during the manufacture.
- Type and batch numbers of all materials used in the work shop where traceability has been specified.
- Acceptance and inspection of incoming materials.
- Identification of moulds and other critical equipment used during the process.
- Identification of personnel participating in critical processes by name or employee number.
- Record of quality inspections carried out during the manufacturing process, including signatures of responsible personnel carrying out these inspections. The type and orientation of reinforcing layers shall be subject to quality inspections following hand lay up.
- Thermographs and hydrographs recorded at representative location(s) in the workshop.
- Curing cycle history of the laminates, recording the temperature and pressure at critical locations during the cure.
- Identification of any test coupons that are manufactured together with the blade.
- Any repairs carried out during manufacture.

104 All measuring equipment shall be calibrated according to a specified scheme. Such equipment includes weights, thermal sensors, hygrometers, load gauges, pressure gauges, and mixing machines with mass or volumetric controls.

105 The as-built documentation shall be filed for a minimum period of 20 years.

**APPENDIX A – SIMPLIFIED LINEAR
ANALYSIS MODELS
(INFORMATIVE)**

A100 General

101 In many blade designs the global bending loads are carried by a beam structure in the blade. This beam is usually composed of symmetrically balanced laminates. The Aerodynamic profile of the blade is based on curved sandwich panels attached to this beam. For this type of structure the strains from global bending can be found by means of simple beam theory.

102 As these beams are not prismatic, simple Bernoulli-Euler beam theory can be applied when modified with correction factors allowing for the effect of flanges that are not parallel.

103 Simple beam theory also ignores the effects of the crushing load due to beam curvature, known as the Brazier effect. This load can be ignored for solid beams, however it shall be considered during the analysis of the blade. If this load is not carried sufficiently by the blade web(s), it will result in increased strains in the blade shells, leading/trailing edge, as well as introducing possible buckling modes.

APPENDIX B – FINITE ELEMENT ANALYSIS (INFORMATIVE)

A100 Modelling of Structures – General

101 Only industry recognised FEA programs shall be used. Other programs shall be verified by comparison with analytical solutions of relevant problems, recognised FEA codes and/or experimental testing.

102 Element types shall be chosen on the basis of the physics of the problem. The choice of the element mesh should be based on a systematic iterative process, which includes mesh refinements in areas with large stress/strain gradients.

103 Problems of moderate or large complexity shall be analysed in a stepwise way, progressing on a simplified model.

104 Model behaviour shall be checked against behaviour of the structure in test. The following modelling aspects shall be treated carefully:

- Load application
- Boundary conditions
- Important and unimportant actions
- Static, quasi-static or dynamic problems
- Damping
- Buckling analysis
- Isotropic or anisotropic material data
- Temperature or strain rate dependent material properties
- Plastic flows
- Nonlinearities (due to geometrical and material properties)
- Membrane effects

Guidance note:

Bending of bolted root joints may be governed by the stiffness of the hub and pitch bearing. The stiffness of the interface shall refer to the technical specification for the blade.

---e-n-d---o-f---G-u-i-d-a-n-c-e---n-o-t-e---

105 Stresses and strains may be evaluated in nodal points or Gauss points. Gauss point evaluation is generally more accurate, and should be used for the analysis of FRP structure where the stress distribution is discontinuous.

Guidance note:

Note that Gauss point results are calculated in local (element or ply based) coordinates and must be transformed (which is automatically performed in most FEA codes) in order to represent global results. Therefore

Gauss point evaluation is more time-consuming than nodal point calculations.

---e-n-d---o-f---G-u-i-d-a-n-c-e---n-o-t-e---

106 Support conditions shall be treated with care. Apparently minor changes in the support can substantially affect the results. In FEA models supports are typically idealised as completely rigid, or as ideally hinged however actual supports conditions often lie somewhere in between. In-plane restraints shall also be carefully treated.

107 Joints shall be modelled carefully. Joints may actually have less stiffness than that predicted in a simple model, which may lead to incorrect predictions of the global model stiffness. Individual modelling of joints is usually not appropriate unless the joint itself is the object of the study.

108 Element shapes should be kept compact and regular to perform optimally. Different element types have different sensitivities to shape distortion. Element compatibility should be kept satisfactory to avoid poor local results such as artificial discontinuities. The mesh should be graded rather than piecewise uniform, thereby avoiding large size discrepancies between adjacent elements.

Guidance note:

Ideally, model checks should be carried out independently before analyses are carried out and results are obtained.

---e-n-d---o-f---G-u-i-d-a-n-c-e---n-o-t-e---

109 The following conditions shall be satisfied in order to avoid ill-conditioning, locking and instability:

- A stiff element shall not be supported by a flexible element, rigid-body constraints shall be imposed on the stiff element instead.
- For plane strain and solid problems, Poisson's ratio must not approach 0.5 unless a special formulation is used.
- 3D elements, Mindlin plate or shell elements shall not be allowed to be extremely thin.
- The reduced integration rule shall not be used without evaluating other possible modes such as hourglass modes.

Guidance note:

Some of these difficulties can be detected by error tests in the coding, such as a test for the condition number of the structure stiffness matrix or a test for diagonal decay during equation solving. Such tests are usually carried out *a posteriori* rather than *a priori*.

The need for mesh refinement can usually be indicated by visual inspection of stress discontinuities in the stress bands. Analogous numerical indices are usually coded and can be used to indicate the need for mesh refinement.

---e-n-d---o-f---G-u-i-d-a-n-c-e---n-o-t-e---

110 For local analysis, a local mesh refinement shall be used. In such an analysis, the original mesh is stiffer than the refined mesh. When the portion of the mesh that contains the refined mesh is analysed separately, a correction shall be made so the boundary displacements to be imposed on the local mesh are consistent with the mesh refinement.

111 For nonlinear problems, the following special considerations shall be taken into account:

- Several trial runs shall be carried out in order to discover and remove any mistake.
- The solution strategy shall be guided by what is learned from the previous attempts.
- Start initially using a simple model, possibly the linear form of the problem, and then add the nonlinearities one by one in subsequent refinements of the model.

112 Computed results shall be checked for self-consistency and compared with alternative analyses, such as approximate analytical results, experimental data, simple text book/handbook analysis, or independent FEA using a different program. In case of a major discrepancy, the reason for the discrepancy shall be sought and the discrepancy justified.

113 The following aspects shall be noted:

- For vibrations, buckling, or nonlinear analysis, symmetric geometry and loads shall be used with caution as the assumption of symmetric response is not always correct. Unless symmetry is known to exist, it shall not be imposed by the selection of boundary conditions.
- For fracture mechanics, quarter point elements can often be too large or too small, possibly making results from any mesh refinement worse.
- The wrong choice of elements may lead to the introduction of a dependency on Poisson's ratio in problems that are known to be independent of Poisson's ratio.
- If plane elements are warped such that element nodes are not co-planar, results may be erratic and very sensitive to changes in the mesh.
- Imperfections of load, geometry, supports and mesh may be far more important in a buckling problem than in problems involving linear response.

114 For FEA of laminate structures, one of the following element types should be applied:

- Layered shell elements with orthotropic material properties for each layer (for in-plane 2D analysis), or

- Solid elements with orthotropic material properties (for 3D and through thickness 2D analysis).

115 The decision to use 2D or 3D analysis methods should be made depending on the level of significance of through thickness stresses and gradients of in-plane stresses through the thickness.

Guidance note:

There are two options for solid elements: the modelling may be performed with (at least) two solid elements through the thickness of each ply; or alternatively layered solid elements can be applied where the thickness of a single element includes two or more plies.

---e-n-d---o-f---G-u-i-d-a-n-c-e---n-o-t-e---

116 Further general guidance for carrying out FEA can be found in DNV-OS-J101.

A200 Software Requirements

201 Selection of the FEA software package for analysis of the blade should be based on the following issues:

- Software availability.
- Availability of qualified personnel having experience with the software and the type of analysis to be carried out.
- Necessary model size.
- Analysis options required.
- Validated software for intended analysis.

Guidance note:

Useful functions for the analysis of FRP structures include:

- Layered solid elements with orthotropic and anisotropic material behaviour.
- Layered shell elements.
- Solid elements with correct material models or appropriate interface elements allowing for debonding (for analysis of bonded and laminated joints).
- Interface elements allowing for large aspect ratio (for analysis of thin layer bonds).
- The possibility to select different co-ordinate systems in a clear and unambiguous way.

Depending on the area of application, additional analysis options should be available, such as:

- Appropriate solver with stable and reliable analysis procedures.
- Options characterising large displacements and large strains (for geometrically nonlinear analysis).
- Material models describing the behaviour of, e.g., laminates beyond first failure (for materially nonlinear analysis).
- Robust incremental procedures (for nonlinear analysis in general).
- Tools for frequency domain analysis and/or options such as time integration procedures (for dynamic analyses).

- Appropriate post-processing functionality.
 - Database options.
 - Sub-structuring or sub-modelling.
- e-n-d---o-f---G-u-i-d-a-n-c-e---n-o-t-e---

A300 Execution of Analysis

301 Caution shall be exercised when working with different relevant co-ordinate systems, i.e. global, ply based, laminate based, element based and stiffener based systems. The chosen approach is to be documented.

A400 Evaluation of Results

401 Analysis results shall be presented in a clear and concise way using appropriate post-processing options. The use of graphics is highly recommended, i.e. contour plots, (amplified) displacement plots, time histories, stress and strain distributions etc.

402 The results shall be documented in a way that will be helpful to the designer in assessing the adequacy of the structure, identifying weaknesses and correction methods, as well as optimisation of the structure.

A500 Validation and Verification

501 FEA programs shall be validated against analytical solutions, test results, or shall be benchmarked against a number of other FE programs.

502 It shall be checked whether the envisaged combination of options has been validated by suppliers. If this is not the case, the necessary validation analysis shall be performed.

503 FEA results shall be validated based on:

- Comparison with relevant analytical results, experimental data and/or results from previous similar analyses
- Analyses and model assumptions
- Comparison against the objectives of the analyses
- The many different relevant co-ordinate systems have been considered and applied logically and correctly
- A comparison of FEA calculated strains with measured strains from the test program, as a minimum the full scale test results shall be compared.

APPENDIX C – BUCKLING ANALYSIS (INFORMATIVE)

A100 Concepts and Definitions

101 The elastic buckling phenomena is commonly analysed in two main modes:

- *Bifurcation buckling*: Increasing applied load induces predominantly axial or in-plane deformations. At a critical applied load (the elastic critical load) a new mode of out of plane bending deformation is introduced. This may result in large deflections immediately with no corresponding increase in the applied load (unstable post-buckling behaviour, brittle type of failure), or grow to large values with little or no increase of load (neutral post-buckling behaviour, plastic type of failure) or develop gradually in a stable manner as the load is increased further (stable post-buckling behaviour, ductile type of failure).
- *Limit point buckling*: As the applied load is increased the structure becomes less stiff until the relationship between load and deflection reaches a maximum (the elastic critical load) where the deformations increase in an uncontrolled manner (brittle type of failure).

102 Determination of the elastic critical load of a structure or member that experiences bifurcation buckling corresponds to the solution of an Eigenvalue problem, where the elastic buckling load is an Eigenvalue and the corresponding mode of buckling deformation is described by the corresponding Eigenvector.

103 Elastic buckling may occur at the following three different levels:

- On a global level, considering the deformation of the entire structure
- Global level for a structural member, confined to a complete single structural member or element
- Local level for a structural member, confined to a specific part of a structural member or element e.g., local buckling of the flange of an I-beam, or of the plate zone between stiffeners in a stiffened plate

104 The resistance of a structural member to elastic buckling is normally expressed as a critical load (the applied force, or resultant stress induced in a member) or as a critical nominal average stress (the axial or shear force divided by cross sectional area). This value can also be expressed as a critical mean strain at the cross section of a member.

105 Initial geometrical imperfections such as: out-of-straightness, out-of-roundness, and

eccentricity of the applied load (situations where the compressive load in the structural member are not coincident with the neutral axis of that part) may significantly influence the buckling behaviour. An idealised structure without such imperfections is referred to as “geometrically perfect”.

106 Bifurcation buckling is essentially a feature of geometrically perfect structures. Geometrical imperfections generally destroy the bifurcation and lead to a situation where bending deformations begin to grow as the applied load is increased. An elastic critical load may still be associated with the structure, and may provide a good indication of the load level at which these deformations become large. However, some structures with unstable post-buckling behaviour are highly sensitive to geometric imperfections. In the presence of imperfections these structures may experience limit point buckling at loads significantly lower than the elastic critical load of the geometrically perfect structure.

107 Elastic buckling deformation of a geometrically perfect or imperfect structure may trigger other failure modes in FRP materials such as fibre failure (compressive or tensile), and matrix cracking. The presence of existing damage such as matrix cracking, or de-lamination may also significantly influence the buckling behaviour of structures and structural members.

A200 General

201 Load carrying main structure in the blades shall not buckle when subjected to the ultimate design loads. The strains in the secondary parts of the blade may be controlled by the displacements at the interface to the load carrying main structure and the impact of the local stiffness on strains may be marginal. For such types of secondary structure buckling is acceptable if it can be proven that it only occurs at rare occasions. Interaction between buckling and fatigue is too complicated to predict with existing design procedures, and requires unique considerations.

202 Simple analytical formulas for buckling of flat and curved orthotropic panels can normally be used to identify if buckling will influence the strain distribution of the blade, or if the strain distribution at extreme loads requires further analysis.

203 Buckling of the wind turbine blade shall be considered as a possible failure mechanism, with global and local buckling being evaluated. The interaction of buckling with other failure mechanisms, such as de-lamination and matrix cracking, is to be considered carefully.

A300 Calculation of Buckling Resistance

301 The need for a special buckling analysis is to be assessed in each case. In particular, the presence

of axial compressive, and shear stresses shall be considered when making this assessment.

302 All parts of the blade such as shell, ribs, joints and fittings shall be evaluated for buckling. Buckling calculations shall be carried out for the major structure of blade panels and webs as a minimum.

303 Buckling analyses should be carried out by analytical or numerical methods. Such analyses should be applied to either geometrically perfect structures or geometrically imperfect structures. Analytical methods are mainly confined to geometrically perfect structures, except for some simple structural members with imperfections of simple shape. If analytical formulae are used for the estimation of critical buckling loads, account shall be taken for the anisotropic properties of the FRP materials utilised in the blade design.

304 When performing a buckling analysis the particular attention is to be given to the definition of boundary conditions.

305 If in any buckling analysis the applied load is higher than the load that would introduce partial damage in the structure e.g., matrix cracking or de-lamination; the buckling calculations shall take this partial damage into account.

306 For structures or structural elements that are expected to exhibit bifurcation buckling, an analysis to determine the elastic critical load (or elastic critical stress or strain) should normally be carried out before a more complex non-linear analysis is performed. The purpose of this is to establish if:

- it is acceptable to perform only geometrically linear analyses
- the structure is clearly under-dimensioned against buckling (if the applied load exceeds, or is close to the elastic critical load)
- the required FEA mesh fineness is used for more complex buckling analysis

307 Analytical formulae for elastic buckling shall be checked carefully if they contain empirical safety factors, and if they are based on structures with or without imperfections. Without this knowledge analytical formulas should not be used.

308 Except in the case of analysis for elastic critical loads (or elastic critical stresses or strains), the analysis model shall incorporate the least favourable geometric tolerances. Alternatively a series of analyses may be performed incorporating a representative range of production tolerances for each process; these may then be combined with statistical information on actual production tolerances in terms of their shape and amplitude distribution.

309 If an adequate knowledge base does not exist, a test program shall be developed to justify the original design assumptions. Wherever possible, assumptions regarding geometrical imperfections shall be based on:

- The relevant manufacturing process (taking into consideration its associated tolerances and imperfections)
- The influences these imperfections have on the structural behaviour
- Prior measurement and test experience

310 Two alternative approaches can be used for the analysis of buckling problems:

- The analysis of isolated components of a standard type e.g., tubular sections, beams, plates and shells, of a simple shape
- The analysis of the entire structure or complex component

311 If imperfections are not directly included in the buckling analysis their effects shall be evaluated by other means such as supplementary analysis or testing. However if it can be demonstrated that the bending moments induced by the least favourable geometric tolerances are less than 10% of the corresponding bending moment inherent in the structure or loading, such as out-of-plane loads, the geometric tolerances may be neglected.

312 When assessing buckling failure modes, the design criteria shall normally be applied at the level of local stress or strain at all points in the structure. The criteria related to fibre failure, matrix cracking, de-lamination, yield and ultimate failure shall be applied as appropriate. For sandwich structures the special criteria shall be applied in addition. Additionally the displacement criterion shall be applied both globally and locally to ensure that there are no excessive buckling displacements.

313 To develop the resistance values required for these checks, geometrically non-linear analyses shall be performed. Reduction of mechanical properties due to local failure such as matrix cracking or de-lamination shall be taken into account.

314 The calculated resistance shall be considered from a probabilistic point of view, taking into consideration variability is introduced by uncertainties in:

- Stiffness parameters used in the buckling calculations
- Geometric parameters and tolerances
- The size of imperfections, and how these imperfections are considered

A400 Buckling analysis of individual components

401 When a member or component that is a part of a larger structure is analysed separately, a global analysis of the structure shall be first applied to establish:

- The effective loading applied to the member/component by the adjoining structural parts.
- The boundary conditions for the structural member in terms of translational- and rotational stiffness in each axis.

402 For simple members or components, standard formulae or tables may be used to estimate elastic critical loads (P_e), critical stresses (σ_e) or critical strains (ϵ_e), and their corresponding elastic buckling mode shapes. Alternatively these quantities may be calculated using analytical or numerical methods. The buckling mode shape shall be checked to be consistent and logical with the boundary conditions.

403 An assessment shall be made of the shape and size of initial geometrical imperfections that may influence the buckling behaviour of the member. Normally the most critical imperfection shape for a given buckling mode has a form similar to the buckling mode itself. However any geometrical feature (including eccentric loading) that results in compressive forces that are not coincident with the neutral axis of the member may require consideration. The assumed form and amplitude of the imperfection shall be decided on the basis of the production process utilised and associated production tolerances.

Guidance note:

In some cases a geometrically non-linear analysis may be avoided as follows:

The elastic critical load (without imperfections) P_e is calculated, and in addition an ultimate failure load P_f is estimated at which the entire cross-section would fail by compressive fibre failure in the absence of bending stresses at the section in question.

If $P_e > P_f$ then further assessment may be based on a geometrically linear analysis provided that geometrical imperfections are included, and the partial load effect modelling factor is increased by the following factor:

$$\frac{1}{1 - P_f / 4P_e}$$

In cases where it is possible to establish the bending responses (stresses, strains or displacements) associated with in-plane loading separately from the in-plane (axial) responses, a first estimate of the influence of geometrical non-linearity combined with the imperfection may be obtained by multiplying the relevant bending response parameter obtained from a geometrically linear analysis by the factor:

$$\frac{1}{1 - P/P_e}, \quad \frac{1}{1 - \sigma/\sigma_e} \quad \text{or} \quad \frac{1}{1 - \epsilon/\epsilon_e}$$

Then combining the modified bending responses with the (unmodified) in-plane responses.

The above approach may be non-conservative for some cases where the post-buckling behaviour is unstable, or where de-lamination and/or matrix failure modes are critical. Examples include cylindrical shells and cylindrical panels under axial loading, and panels with de-lamination defects. Such cases shall be subject to special analysis, tests, or both.

---e-n-d---o-f---G-u-i-d-a-n-c-e---n-o-t-e---

A500 Buckling analysis of more complex elements or entire structures

501 Buckling analysis of more complex elements or entire structures is to be carried out with the aid of verified FE software or equivalent analysis methods. Careful attention is to be paid to the correct modelling of boundary conditions, and the influence of geometric imperfections is to be assessed on the basis of the laminate production method and tolerances.

502 Initially an Eigenvalue buckling analysis should be performed assuming initial (non-degraded) elastic properties for the laminates. This analysis is to be repeated with alternative, finer meshes, until the Eigenvalues and corresponding Eigenmodes have diverged. The purpose of this analysis is to clarify the relevant buckling mode shapes, as well as establishing the required mesh density for subsequent analysis.

503 If the applied load exceeds, or is close to, the calculated elastic critical load then the design should be modified to improve the buckling strength before proceeding further with design development.

504 A logical step-by-step analysis should be carried out, with geometrical non-linearities included in the model. The failure criteria should be checked at each step. If failure such as matrix cracking or de-lamination is foreseen, any analysis for higher loads shall be performed with reduced properties.

505 As an alternative, a geometrically non-linear analysis may also be performed using entirely degraded properties throughout the structure. This will normally provide conservative estimates of stresses and deformations. Provided reinforcing fibres are present in sufficient directions, so that the largest range of non-reinforced directions does not exceed 60°, such an estimate will normally not be overly conservative.

APPENDIX D – FIBRE FAILURE ANALYSIS (INFORMATIVE)

A100 General

101 Fibre failure is defined as the first fibre failure of a ply/lamina by fracture. The fibre strength, or strain to failure, is to be based on test results from plies or laminates. The definition of ply/lamina failure during static test is the rupture of the fibres in the ply.

102 The maximum strain criterion is to be used to check fibre failure. Other design criteria may be used if it can be demonstrated that they are equivalent to or conservative relative to the maximum strain criterion given here.

103 Fibre failure is to be checked at the individual ply level, not at the laminate level. Regardless of the analysis method used, analysis is to be conducted with non-degraded matrix dominated elastic constants, i.e., E_{11} , E_{22} , G_{12} , ν_{12} .

Guidance note:

This condition is typical for UD laminates where all fibres run parallel in one direction throughout the thickness of the laminate. Great care should be taken when using such laminates due to their low properties in all other directions than the fibre direction.

---e-n-d---o-f---G-u-i-d-a-n-c-e---n-o-t-e---

A200 Maximum strain criterion

201 For single loads the maximum strain design criterion is given as:

$$\epsilon_{nk} < \hat{\epsilon}_k^{fiber}$$

Where:

ϵ_{nk} Strain response in the fibre direction at the design load

$\hat{\epsilon}_k^{fiber}$ Design value of the axial strain to fibre failure

Guidance note:

The above values refer to design values, and include appropriate safety factors as per Section 3 A500.

---e-n-d---o-f---G-u-i-d-a-n-c-e---n-o-t-e---

202 For each fibre direction of the laminate the partial analysis factor is to be given by:

$$\gamma_A = E_{lin}/E_{nonlin},$$

203 Where: E_{lin} and E_{nonlin} are laminate moduli (stiffness) related to loading in the fibre direction of consideration. E_{lin} is the laminate stiffness based on initial (non-degraded) ply properties, while E_{nonlin} is the reduced laminate stiffness obtained from

degraded ply properties due to matrix cracking. This relationship is shown in Figure 6.

Guidance note:

The introduction of partial analysis factors, γ_A above can be thought of as a reduction of the effective strain to failure from $\hat{\epsilon}$ to $\hat{\epsilon}_{corr}$ (mean values) as shown for a typical stress-strain curve for a laminate containing 0, 45 and 90 layers when loaded in the 0 direction.

A partial analysis factor shall be calculated for each fibre direction of the laminate, which in this example corresponds to obtaining laminate stress-strain relations for loading in the 0, 45 and 90 degrees directions for the laminate.

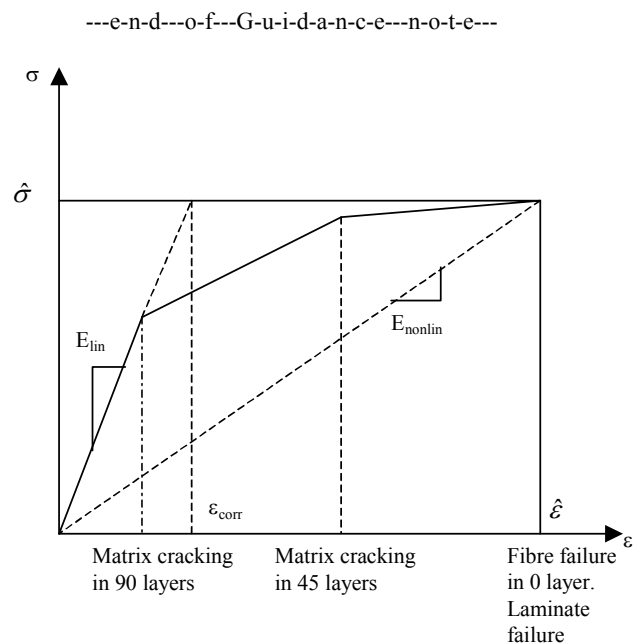

Figure 6 - Typical stress-strain relation for a laminate containing 0, 45 and 90 layers

204 The maximum strain criterion shall be checked in all n directions parallel to the fibres, and for tensile and compressive strains. $\hat{\epsilon}_k^{fiber}$ is the time dependent characteristic strength of the ply in the fibre direction, a constant value for each fibre type is to be used.

A300 Tsai-Hill criterion

301 When two or more in-plane stresses are applied to a lamina/ply, a useful failure criterion is the Tsai-Hill maximum distortional energy theory. This theory takes into account the interaction of stresses, and can be expressed in 2D as:

$$\left(\frac{\sigma_1}{\hat{\sigma}_1}\right)^2 + \left(\frac{\sigma_2}{\hat{\sigma}_2}\right)^2 + \left(\frac{\tau_{12}}{\hat{\tau}_{12}}\right)^2 - \frac{\sigma_1\sigma_2}{\hat{\sigma}_1^2} \geq 1$$

302 This equation and associated testing requirements may be further simplified with the following conservative assumption:

$$\hat{\tau}_{12} = \frac{\hat{\sigma}_2}{2}$$

A400 Modified Tsai-Wu criterion

401 In many cases the maximum fibre strain criterion is not available in commercial software packages. As an alternative the Tsai-Wu criterion can also be used with modified input parameters as described here. Tsai-Wu strength tensor theory models the interactions of stresses in three dimensions, however relies on bi-axial structural testing to establish the empirical interaction parameters.

402 The Tsai-Wu criterion can be described in 3D as:

$$\begin{aligned} & (F_{11}\sigma_1^2 + F_{22}\sigma_2^2 + F_{33}\sigma_3^2 + F_{12}\tau_{12}^2 + F_{13}\tau_{13}^2 + F_{23}\tau_{23}^2) \\ & + (2H_{12}\sigma_1\sigma_2 + 2H_{13}\sigma_1\sigma_3 + 2H_{23}\sigma_2\sigma_3) \\ & + (F_1\sigma_1 + F_2\sigma_2 + F_3\sigma_3) < 1 \end{aligned}$$

403 Or can be described in 2D as:

$$(F_{11}\sigma_1^2 + F_{22}\sigma_2^2 + F_{12}\tau_{12}^2 + 2H_{12}\sigma_1\sigma_2) + (F_1\sigma_1 + F_2\sigma_2) < 1$$

Where:

$$F_{11} = \frac{1}{\hat{\sigma}_{1t}\hat{\sigma}_{1c}}, F_{22} = \frac{1}{\hat{\sigma}_{2t}\hat{\sigma}_{2c}}, F_{33} = \frac{1}{\hat{\sigma}_{3t}\hat{\sigma}_{3c}}$$

$$F_{12} = \frac{1}{\hat{\tau}_{12}^2}, F_{13} = \frac{1}{\hat{\tau}_{13}^2}, F_{23} = \frac{1}{\hat{\tau}_{23}^2}$$

$$F_1 = \frac{1}{\hat{\sigma}_{1t}} - \frac{1}{\hat{\sigma}_{1c}}, F_2 = \frac{1}{\hat{\sigma}_{2t}} - \frac{1}{\hat{\sigma}_{2c}}, F_3 = \frac{1}{\hat{\sigma}_{3t}} - \frac{1}{\hat{\sigma}_{3c}}$$

$$H_{12}^* = \frac{H_{12}}{\sqrt{F_{11}F_{22}}}, H_{13}^* = \frac{H_{13}}{\sqrt{F_{11}F_{33}}}, H_{23}^* = \frac{H_{23}}{\sqrt{F_{22}F_{33}}}$$

And:

- n The ply co-ordinate system
- σ_n Stress in the n direction for the design load.
- $\hat{\sigma}_{nt}$ Design tensile strength in the direction n .
- $\hat{\sigma}_{nc}$ Design compressive strength in the direction n .
- $\hat{\tau}_n$ Design shear strength in the direction n .

404 Failure is predicted when the Tsai-Wu criteria is met i.e., equals or is greater than 1. The interaction parameters H_{12}^* , H_{13}^* , H_{23}^* require off-axis tensile and compressive tests, and/or biaxial testing to evaluate for each FRP material combination.

405 Since the Tsai-Wu criterion is only used to check for fracture of the laminate small matrix cracks are acceptable, however the strength properties should be developed as described below. Characteristic strengths shall be used.

$$\hat{\sigma}_{2t} = \frac{E_2}{E_1} \hat{\sigma}_{1t} \quad \text{Modified in-plane tensile ply strength}$$

$$\hat{\sigma}_{2c} = \frac{E_2}{E_1} \hat{\sigma}_{1c} \quad \text{Modified in-plane compressive strength}$$

406 If the tensile and compressive fibre strengths differ by more than 60%, then alternative design criteria (i.e., matrix failure) shall be checked to ensure that they do not give lower allowable stresses than this criterion.

A500 Special considerations for in-plane compressive loads

501 The orientation of matrix cracks shall be checked if the compressive strength of a laminate is considered critical.

502 If matrix cracking with an orientation of 30°-60° relative to the plane of the laminate is present, the compressive strain to fibre failure used in the design criteria of this section is to be obtained by test from laminates with the presence of matrix cracks with an orientation between 30° and 60°. Alternatively, the compressive strain to failure can be reduced by 50%, or a component test carried out.

A600 Fracture mechanics approach

601 The fibre design criteria described above can always be used. However, in the presence of stress concentrations that reach infinity a fracture mechanics approach should be applied.

602 Stress concentration can be caused by the following factors:

- Cut-outs and holes.
- Discontinuous linear and smooth geometry (including rough edges).
- Bolted, bonded, and other mechanical joints.
- A mismatch of elastic properties between two adjacent components or materials.
- Voids and other damages due to material fabrication.

603 UD FRP material is to be avoided in the presence of stress concentrations (such as at holes) as matrix cracking and delamination can propagate from that point through the structure with minimal resistance.

APPENDIX E – MATRIX FAILURE ANALYSIS (INFORMATIVE)

A100 General

101 Matrix cracking is defined as the onset of matrix cracking, with the increase in the number of matrix cracks at higher stresses or strains not being covered by the matrix cracking criteria presented in this section.

102 Two alternative design criteria can be used: the maximum stress criterion, and the Puck criterion. Matrix failure is not to be analysed on a laminate level, it is to always be checked on an individual ply/lamina level.

103 If a structural area can fail due to wedge shaped matrix cracks under compression loading, the Puck criterion is to be used to obtain the direction of the failure surface.

Guidance note:

Matrix cracking is a simple concept at first; however the details can be quite complicated. Some laminates already have matrix cracks present following manufacture, with these cracks are introduced through thermal stresses or shrinkage of the matrix during the cure cycle. Laminates without matrix cracks have an initial ply stress when the first cracks start to form.

Once cracks are formed, they begin to propagate at higher ply stresses and additional cracks are formed. This crack formation will eventually lead to a change in stiffness, which is referred to as the matrix cracking point, or first ply failure.

Eventually laminates show crack saturation and no further cracks form with load application. The change of modulus has been related to matrix crack density in some publications.

---e-n-d---o-f---G-u-i-d-a-n-c-e---n-o-t-e---

A200 Maximum stress criterion

201 The maximum stress criterion should be used when the stress in one direction is dominating compared to the stresses in the other directions. In this case, the simple maximum stress criterion for a dominating stress is:

$$\sigma_{nk} < \hat{\sigma}_{nk}^{matrix}$$

Where:

- n Direction of the dominating stress
- σ_{nk} Value of the local load effect of the structure (stress) in the direction n for the design load
- $\hat{\sigma}_{nk}^{matrix}$ Design value of the stress components to matrix cracking in the direction n
- n The ply coordinate system.

Guidance note:

The maximum stress in the matrix is generally direction-dependent. This is due to the presence of fibres that concentrate the stresses, such that the matrix stress to failure in the longitudinal direction (σ_1) to the fibres is generally larger than that in the transverse direction (σ_2).

---e-n-d---o-f---G-u-i-d-a-n-c-e---n-o-t-e---

202 The stress is said to be dominating when the criterion below is satisfied:

$$\max_i \left| \frac{\sigma_{ik}}{\hat{\sigma}_{ik}^{matrix}} \right| / \sum_{n \neq i} \left| \frac{\sigma_{nk}}{\hat{\sigma}_{nk}^{matrix}} \right| \geq 10$$

203 In the case where this criterion is not met, then there is no dominating stress, and the simple maximum stress criterion cannot be used. The combined effect of the stress components is to be evaluated, with the maximum stress criterion for a complex stress state being given by:

$$\sqrt{\sum_n \left(\frac{\sigma_{nk}}{\hat{\sigma}_{nk}^{matrix}} \right)^2} < 1$$

Where:

- n The ply coordinate system
- σ_{nk} Value of the local load effect of the structure (stress) in the direction n for the design load
- $\hat{\sigma}_{nk}^{matrix}$ Design value of the stress components to matrix cracking in the direction n

Guidance note:

The maximum stress criterion is often not available in FE codes or other commercial software. It is recommended however to use Puck's criterion to analyse matrix failure.

The Tsai-Wu criterion can also be used to check for matrix failure if the following modifications are made to the strength parameters:

- The ply strengths in fibre direction is chosen as dominating (at least 1000 times higher than actual values)
- The interaction parameter H^*_{12} be set at 0

---e-n-d---o-f---G-u-i-d-a-n-c-e---n-o-t-e---

A300 Puck's criterion

301 Matrix failure can also be predicted using Puck's criterion which evaluates the stress state over all possible failure surfaces.

302 The orientation of the failure surface is described by the angle θ . The stress state $\sigma_n, \tau_{nt}, \tau_{nl}$ in the co-ordinates of the failure surface described by θ is obtained from the ply stresses by:

$$\begin{Bmatrix} \sigma_n \\ \tau_{nt} \\ \tau_{nl} \end{Bmatrix} = \begin{bmatrix} c^2 & s^2 & 2sc & 0 & 0 \\ -sc & sc & (c^2 - s^2) & 0 & 0 \\ 0 & 0 & 0 & s & c \end{bmatrix} \begin{Bmatrix} \sigma_2 \\ \sigma_3 \\ \tau_{23} \\ \tau_{31} \\ \tau_{21} \end{Bmatrix}$$

Where:

$$\begin{aligned} c &= \cos \theta \\ s &= \sin \theta \end{aligned}$$

303 Additionally the stress component σ_{II} in the fibre direction is needed ($\sigma_{II} = \sigma_I$). Failure is evaluated based on the stress state σ_n , τ_{nt} , τ_{nl} for all angles θ between -90 and 90 degrees. The design criterion is:

$$\text{if } \sigma_n(\theta) \geq 0$$

$$\max \left[F_f \sigma_{II} + \sqrt{(F_{mn}^+ \sigma_n(\theta))^2 + (F_{nt} \tau_{nt}(\theta))^2 + (F_{nl} \tau_{nl}(\theta))^2 + F_n^+ \sigma_n(\theta)} \right] < 1$$

for all θ with $-90 \leq \theta \leq 90$,

$$\text{if } \sigma_n(\theta) < 0$$

$$\max \left[F_f \sigma_{II} + \sqrt{(F_{mn}^- \sigma_n(\theta))^2 + (F_{nt} \tau_{nt}(\theta))^2 + (F_{nl} \tau_{nl}(\theta))^2 + F_n^- \sigma_n(\theta)} \right] < 1$$

for all θ with $-90 \leq \theta \leq 90$,

Where:

σ_n Values of the local load effect of the structure
 F_{ik} Strength factors

304 The strength factors F_{ik} are functions of the ply strength parameters:

$$\hat{\sigma}_{2t}^{matrix}, \hat{\sigma}_{2c}^{matrix}, \hat{\tau}_{12}^{shear}, \hat{\sigma}_{1t}^{fibre}, \hat{\sigma}_{1c}^{fibre}$$

305 The shape parameters of the failure surface are defined as:

$$F_f = \frac{1}{A_t \hat{\sigma}_{1t}^{fibre}} \text{ if } \sigma_{II} \geq 0 \text{ and } F_f = \frac{1}{A_c \hat{\sigma}_{1c}^{fibre}} \text{ if } \sigma_{II} < 0$$

$$F_{mn}^+ = \frac{1}{R_{\perp}^z} - \frac{p_{\perp\psi}^{(+)}}{R_{\perp\psi}^A}, F_{mn}^- = \frac{p_{\perp\psi}^{(-)}}{R_{\perp\psi}^A}$$

$$F_n^+ = \frac{p_{\perp\psi}^{(+)}}{R_{\perp\psi}^A}, F_n^- = \frac{p_{\perp\psi}^{(-)}}{R_{\perp\psi}^A}$$

$$F_{nt} = \frac{1}{R_{\perp\perp}^A}, F_{nl} = \frac{1}{R_{\perp\parallel}^A}$$

With:

$$A_t = A_c = 1.6$$

$$\frac{\tau_{nl}}{\tau_{nt}} = \tan \psi$$

$$\frac{p_{\perp\psi}^{(+)}}{R_{\perp\psi}^A} = \frac{p_{\perp\perp}^{(+)}}{R_{\perp\perp}^A} \cos^2 \psi + \frac{p_{\perp\parallel}^{(+)}}{R_{\perp\parallel}^A} \sin^2 \psi$$

$$\frac{p_{\perp\psi}^{(-)}}{R_{\perp\psi}^A} = \frac{p_{\perp\perp}^{(-)}}{R_{\perp\perp}^A} \cos^2 \psi + \frac{p_{\perp\parallel}^{(-)}}{R_{\perp\parallel}^A} \sin^2 \psi$$

$$R_{\perp\perp}^A = \frac{R_{\perp}^d}{2(1 + p_{\perp\perp}^{(-)})}$$

306 The shape parameters $p_{\perp\parallel}^{(+)}, p_{\perp\parallel}^{(-)}, p_{\perp\perp}^{(+)}, p_{\perp\perp}^{(-)}$ shall be determined by test. If they are not available, then the following values are recommended to be used:

$$p_{\perp\parallel}^{(+)} = 0,30, p_{\perp\parallel}^{(-)} = 0,30, p_{\perp\perp}^{(+)} = 0,15, p_{\perp\perp}^{(-)} = 0,27 \quad R_{\perp}^z = \hat{\sigma}_{2t}^{matrix}$$

$$R_{\perp}^d = \hat{\sigma}_{2c}^{matrix}$$

$$R_{\perp\parallel} = \hat{\tau}_{12}^{shear}$$

307 The resistance model factor γ_{Rd} shall be chosen to be 1.1. The resistance model factor ensures a conservative result accounting for the simplifications of combined loads.

308 The orientation of the fibre failure surface is critical if the structure is loaded in compression. Matrix failure surfaces with an orientation of 30° to 60° relative to the plane of the laminate can reduce compressive fibre strength and reduce the resistance to de-lamination.

309 The orientation of the failure surface should be determined with Puck's criterion by finding the angle θ at which the matrix design criterion reaches its maximum.

310 If the matrix cracking at an orientation of 30° to 60° relative to the plane of the laminate is critical, then the compressive fibre strength is to be measured by test on laminates with the presence of such cracks and this value shall be used in the fibre design criterion. The tested laminate is to be representative of the application.

Guidance note:

Matrix cracks with an orientation of 30° to 60° occur mainly when the ply is exposed to compressive stresses or a combination of in-plane shear stresses and high compressive stresses.

---e-n-d---o-f---G-u-i-d-a-n-c-e---n-o-t-e---

A400 In-plane shear failure

401 The potential in-plane shear failure mode for a matrix can be checked using the maximum stress criterion, limiting stresses to in-plane shear (σ_{12})

only. For simple 2D in-plane shear conditions the design criterion reduces to:

$$\tau_{12} < \hat{\tau}_{12}^{matrix}$$

Where:

τ_{12} In-plane shear stress.

$\hat{\tau}_{12}^{matrix}$ Design value of the matrix in-plane shear stress capacity.

A500 Von Mises yield criterion

501 The Von Mises yield criterion can be used for the evaluation of isotropic materials undergoing yield, such as the typically isotropic matrix material in an FRP laminate. The Von Mises yield criterion is given by:

$$\sqrt{(\sigma_1 - \sigma_2)^2 + (\sigma_2 - \sigma_3)^2 + (\sigma_3 - \sigma_1)^2} < \sigma_y$$

Where:

σ_n Principal stresses, n=1, 2, 3 for the design load

σ_y Design value of the yield stress of the material

502 When two or more loads are present, each stress component σ_n can be the result of combined loading. In this case, for each stress component σ_n^j the local response of the structure in direction n due to load j is to be considered separately.

503 Unless it can be adequately demonstrated that the structure can tolerate large permanent deformations, any yielding of the matrix material is unacceptable.

**APPENDIX F – INTER-LAMINAR
FAILURE ANALYSIS
(INFORMATIVE)**

A100 General

101 Inter-laminar failure is a mode of failure where the matrix (or adhesive) of a laminate fails between adjacent laminae due to shear (τ_{xy}) or normal (σ_z) stresses. This failure can lead to separation of the individual laminae forming a delamination that can grow further once initiated.

102 Delamination can also occur in a sandwich structure at the bond interface between the core material and the laminate, as well as at the bond line for bonded joints. The three commonly accepted inter-laminar failure modes are shown in Figure 7.

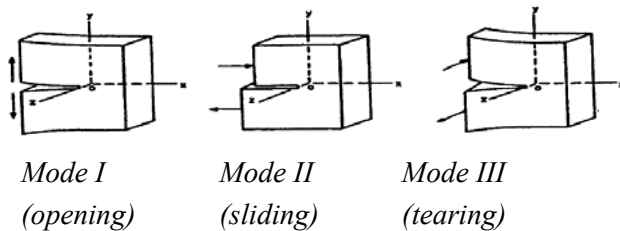

Figure 7- Inter-laminar failure modes

A200 Onset of de-lamination

201 The onset of de-lamination due to normal or in-plane stresses is difficult to predict. It is known that de-lamination will not initiate before matrix cracks have formed. It is therefore a conservative approach to model the onset of de-lamination with the matrix failure criteria of section 3H, and to supplement these analyses with test and experience.

A300 Delamination growth

301 Growth of inter laminar cracks can be modelled with a fracture mechanics approach. The crack will propagate when the strain energy release rate (G) reaches the critical strain energy release rate ($G_{critical}$). The design criterion is therefore given for each failure mode (n) by:

$$G < G_{n-critical}$$

302 The value for G is to be calculated using local inter-laminar stresses, with $G_{critical}$ being determined by test.

303 $G_{critical}$ often depends on the crack length. Conservative assumptions on crack length shall be made with reference to documented studies on similar materials and conditions. $G_{critical}$ is to be chosen for the appropriate crack opening mode, for mixed mode conditions $G_{critical}$ is to be calculated as a weighted average of the crack opening modes (i.e., $G_{I critical}$, $G_{II critical}$, and $G_{III critical}$).

**APPENDIX G – SANDWICH
FAILURE ANALYSIS
(INFORMATIVE)**

A100 General

101 Sandwich structures are generally constructed of a light weight core embedded between two faces or skins. The design criteria for skins, cores and the core skin interface will now be discussed.

A200 Typical sandwich failure mechanisms

201 Sandwich structures have additional failure mechanisms due to the interaction between the laminate and the core material, typical sandwich failure mechanisms are shown in Figure 8.

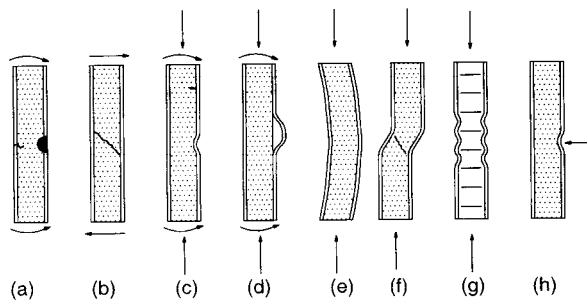

- | | |
|-----------------------------|-----------------------------|
| (a) face/core failure | (e) general buckling |
| (b) core shear | (f) shear crimping buckling |
| (c) face wrinkling buckling | (g) face dimpling buckling |
| (d) de-lamination | (h) core indentation |

Figure 8 - Typical sandwich structure failure modes

203 In many cases the dominant stress in the core material is shear, causing shear yield, shear ultimate failure, or tensile failure in 45° to the through thickness direction. Core indentation due to local compressive stress is also to be checked, with core indentation occurring if the compressive strength of the core material is exceeded.

A300 Sandwich core ultimate failure

301 Failure of brittle and plastic core materials shall be checked using the design criterion for orthotropic homogenous materials, i.e. materials with three axes of symmetry. Isotropic materials are included, since they are a sub-group of orthotropic materials. This criterion is typically applied to core materials. Strength values shall be determined relative to the axes of material symmetry.

302 The criterion can be applied to brittle core materials or to polymeric materials after yield. The following design criterion should be used when the

stress in one direction is dominating compared to the stresses in the other directions.

$$\sigma_{nk} < \hat{\sigma}_{nk}$$

Where:

- n Direction of the dominating stress
- σ_{nk} Value of the local load effect of the structure (stress) in the direction n for the design load
- $\hat{\sigma}_{nk}$ Design strength

Guidance note:

A typical example for core materials in a sandwich would be to check that the through thickness shear stress does not exceed the shear strength. In many cases the shear stress is the dominating stress component, however, this shall be checked with the criterion.

---e-n-d---o-f---G-u-i-d-a-n-c-e---n-o-t-e---

303 The interaction between the stress components in several directions shall be taken into consideration when the following criterion is satisfied. In that case, there is no dominating stress and the interaction can not be disregarded.

$$\max_i \left| \frac{\sigma_{ik}}{\hat{\sigma}_{ik}} \right| / \sum_{n \neq i} \left| \frac{\sigma_{nk}}{\hat{\sigma}_{nk}} \right| \leq 10$$

304 For isotropic materials the directions shall be either the principal normal stresses or the principal shear stresses. For orthotropic materials the directions shall be the material axes.

305 When the interaction between the stress components in several directions shall be taken into consideration, the design criterion below shall be applied. The criterion shall be applied for tensile and compressive stresses.

$$\sqrt{\sum_n \left(\frac{\sigma_{nk}}{\hat{\sigma}_{nk}} \right)^2} < 1$$

Where:

- n Refers to the ply coordinate system
- σ_{nk} local stress in the direction n
- $\hat{\sigma}_{nk}$ Design strength

306 For orthotropic materials the directions shall be the material axes. For isotropic materials the directions shall be along either the principal normal stresses or the principal shear stresses. This is a conservative design criterion, and has been chosen due to a lack of data and experience with ultimate failure under multiple stress conditions. Other design criteria may be used if experimental evidence for their validity can be given.

A400 Sandwich core yielding

401 Many core materials show plastic behaviour. If yielding cannot be accepted in the sandwich structure the yield criterion is to be applied.

Yielding design criteria apply to most polymeric core materials of sandwich structures. The Von Mises design criteria can be applied to a matrix material with plastic characteristics if the matrix is located in a region where it is not restrained between fibres, e.g. in the case of resin rich layers.

402 Foam cores under significant face wise compression (crushing) or tension shall be checked in addition for ultimate failure of orthotropic homogenous materials. Significant face wise compression or tension exists if:

$$0.1\sigma_3 \leq \frac{1}{3}(\sigma_1 + \sigma_2 + \sigma_3) \leq 0.1\sigma_1$$

Where $\sigma_1, \sigma_2, \sigma_3$ are the principal stresses with $\sigma_1 > \sigma_2 > \sigma_3$.

403 Design criteria can be developed where local yielding in a structural element is accepted if it can be adequately demonstrated that the structure can tolerate large permanent deformations. Such design criteria are not described further in this standard.

A500 Sandwich Interface

501 The sandwich faces or skins shall be analysed as a laminate using the methods described in this section. Both faces shall be checked for failure, since they will be exposed to different stress states if exposed to bending loads.

502 Interface failure between the skin and core of a sandwich shall be analysed for their inter-laminar stresses, with care taken for the use of representative material properties when applying the design criterion. Interface properties usually differ from the core or laminate properties, and should be determined by test.

503 Sandwich structures with PVC core typically show no failure directly at the interface; however they fail inside the PVC core below the interface. Sandwich structures with Balsa core fail typically at the interface.

A600 Sandwich structure buckling

601 Sandwich structures show some special buckling modes. The additional modes of face wrinkling, shear crimping, and face dimpling shall be evaluated.

602 Face wrinkling will occur when the compressive direct stress in the face will reach the local instability (or wrinkling) stress, i.e.

$$\bar{\sigma}_{face} \geq \hat{\sigma}_{wrinkling}$$

603 Shear crimping will occur when the direct stress will reach the crimping stress.

$$\bar{\sigma}_{face} \geq \hat{\sigma}_{crimping}$$

604 Face dimpling or intercellular buckling occurs only in sandwich structures with honeycomb and corrugated cores. Face dimpling will occur when the compressive stress in the cell wall reaches the buckling stress of a honeycomb cell or a corrugated core, i.e.

$$\bar{\sigma}_{core} \geq \hat{\sigma}_{dimpling}$$

**APPENDIX H – FATIGUE LIMIT
STATE ANALYSIS (INFORMATIVE)**

A100 General

101 An evaluation of the strength, detail design, and manufacturing processes must demonstrate that the failure due to fatigue will be avoided throughout the service life of the wind turbine.

102 All failure modes evaluated during the static analysis should be evaluated for potential fatigue failure, with the identification of critical elements and locations along the blade where fatigue failure could occur. These locations normally include details that cause stress concentrations or at load introduction and transfer points.

103 The material stiffness degradation due to cyclic loading is also to be evaluated.

A200 Cyclic Fatigue

201 All cyclic loading imposed during the entire service life that has a magnitude and corresponding number of cycles large enough to cause fatigue damage effects are to be taken into account. For further detailed guidance refer to Annex G of IEC 61400-1.

Guidance note:

The entire service life includes transport, installation, operation and repair.

---e-n-d---o-f---G-u-i-d-a-n-c-e---n-o-t-e---

202 For fatigue analysis the stress or strain fluctuations can be specified in terms of: mean, amplitude, and number of cycles as shown in Figure 9.

<i>Number of cycles</i>	<i>Mean load</i>	<i>Amplitude</i>
N_1	F_1	A_1
N_2	F_2	A_2
.	.	.
.	.	.
n_n	F_n	A_n

Figure 9- Tabular representation of fatigue loads

203 As an alternative to tabular representation, the fatigue loads can be represented in matrix form with one row for each mean strain, one column for each strain amplitude, and number of cycles as the entry of each matrix element as shown below in Figure 10.

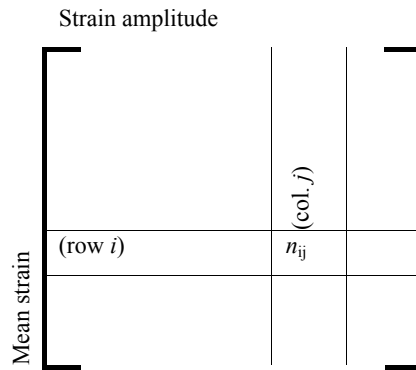

Figure 10 - Matrix representation of fatigue loads

Guidance note:

A detailed history of mean stress/strain, amplitudes, and cycles is needed for fatigue analysis. For non-linear analysis the mean may shift relative to the amplitude during the transfer from applied load to load response, this should be taken into consideration.

A minimum resolution (or width) for the discrete values of stress/strain should be defined, and then the detailed history be established in discrete form by rain flow analysis.

If the time duration of some cycles is long or if the mean value is applied over a long time, these loads may have to be considered for sustained load cases (stress rupture) as well.

Degradation is a non-linear, history-dependent process. If different loading and environmental conditions can cause different degradation histories, all relevant load combinations shall be considered.

---e-n-d--- o-f---G-u-i-d-a-n-c-e---n-o-t-e---

204 Based on the material properties, in particular the *S-N diagram* and the magnitude of its slope parameter, it shall be assessed whether the majority of the fatigue damage will be caused by several thousand or more stress cycles from the characteristic stress distribution, or if it will be caused by only one or a very few extreme stress amplitudes from this distribution.

205 In the former case, the natural variability in the individual stress amplitudes can be disregarded as its effect on the cumulative damage will average out, and the load factor can be set equal to 1.0. In the latter case, the natural variability in the few governing extreme stress amplitudes cannot be disregarded and needs to be accounted for by a load factor greater than 1.0. If no detailed analysis of the load factor can be made, the same factors as those for static loads shall be used.

206 Typically, S-N curves for composite materials are developed based on the following exponential relationship:

$$N \propto (\Delta S)^{-m}$$

Where:

N number of cycles to failure
 ΔS the cyclic stress or strain range
m Wöhler coefficient

207 Normally the methods based on S-N diagrams and the reduction of strength with time is used during design for fatigue life assessment. If representative fatigue resistance data is not available for the area under consideration, direct fatigue testing is to be performed under representative conditions.

208 The stress to be considered for fatigue in a wind turbine blade is the *cyclic* (i.e., time-dependent) stress. Both the mean value and amplitude shall be obtained.

209 As the combined stresses vary around the circumference and length of the wind turbine blade, the fatigue damage must be calculated at distributed points to identify the most critical locations.

A300 Fibre failure in fatigue

301 Fatigue analysis can be performed at both a ply/lamina level and a laminate level. On the laminate level, fatigue testing data is to be based on laminates with representative lay-ups to ensure that representative interactions between the plies are accounted for.

302 If an area is exposed to both static and cyclic loads over time, then the combined effect shall be taken into account. As a conservative assumption, these effects can be superimposed. Other load combinations may be used if experimental evidence can be provided. If fatigue is analysed or tested with a mean load that corresponds to the permanent static load, effects of static and cyclic fatigue may be considered separately.

303 Matrix cracking can initiate under cyclic loading even if the maximum stress is below the level to initiate matrix cracking in a static test. The effect of matrix cracking is to be considered in the fatigue analysis.

A400 Change of elastic properties

401 Applied cyclic loading can also change the elastic properties of the material, with this change being of a permanent nature in most cases.

402 A change in elastic properties can result in strain redistribution on the global level, and/or in the exceedance of the maximum displacement requirements. If the strain redistribution is thought critical, then a static analysis with these changed elastic constants is to be performed. If displacement

requirements are observed, then the displacement criterion is to be met with changed elastic properties in the analysis.

Guidance note:

The change of elastic constants is usually a result of an accumulation of matrix cracks under cyclic fatigue.

---e-n-d---o-f---g-u-i-d-a-n-c-e---n-o-t-e---

403 In some cases a specific contact pressure may be required for an area or component; it shall be documented that the change of elastic constants due to cyclic fatigue will not reduce this contact pressure to an unacceptable level.

Guidance note:

A specified contact pressure is often needed for bolted connections, or if a component is kept in place by friction.

---e-n-d---o-f---g-u-i-d-a-n-c-e---n-o-t-e---

A500 Initiation of fatigue damage

501 All failure mechanisms shall be checked for fatigue, unless a particular failure mechanism is acceptable for the structure. The approach is basically the same for all failure mechanisms; however different S-N curves and residual strength values shall be considered.

502 A fatigue analysis shall contain two steps:

- Can the structure survive the expected load sequence?
- Is the structure strong enough that it can survive all relevant extreme loads through its service life?

503 A Constant Lifetime Diagram diagramme shall be constructed from the available characteristic S-N curves if the structure is exposed to fatigue stresses of other R-ratios than the measured ones or to various R-ratios. The diagram can be used to extrapolate expected number of cycles to failure for different combinations of mean and amplitude. The characteristic number of cycles to failure $n^{character}(\epsilon_{applied})$ shall be extracted for each applied strain condition (amplitude and mean level) from the constant lifetime diagram. The number of expected cycles to failure shall be found for the applied strains ($\epsilon_{applied}$).

Guidance note

Constant Lifetime Diagram CLD diagrammes are commonly used to obtain fatigue lifetimes given as number of cycles N for a given stress amplitude S and mean. Fatigue data are often only available for three R-ratios, R=10, -1, and 0.1. These data represent three lines in the CLD diagram; other values have to be extrapolated. Linear extrapolations may be used, giving the CLD diagram typically triangular shape.

Figure 11 gives an example of a CLD diagram. The diagram was based on characteristic S-N diagrams measured at the R-ratios R=10, -1, and 0.1. In addition the characteristic static tensile and compressive strains at failure were needed. The CLD diagram can be divided into four sectors in this case. The sectors are shown in Figure 4-2. Within each sector constant life lines were drawn for lifetimes of 10, 100, 1000... cycles. These lines are assumed to be straight.

For sectors 1 and 4 all lines were connected to the static tensile and compressive strains at failure. If fatigue data at other R-ratios exist an equivalent approach with more (or less) sectors can be used.

The expected lifetime N^{exp} for a given strain amplitude α and mean η can be found by the following procedure (see also Figure 4-2):

- Draw the point P in the constant amplitude life diagram representing the given strain amplitude α and mean η .
- Draw a line a from the origin of the constant amplitude life diagram (0 mean, 0 amplitude) through and beyond the point P.
- Identify the two closest constant life lines nearest to P, n_1 and n_2 , where n_2 is the line with the higher number of cycles to failure.
- Measure the length a_1 on line a between the two constant life lines n_1 and n_2 nearest to P.
- Measure the length a_2 on line a between point P and the constant life line n_2 with the higher number of cycles nearest to P.
- Find the line b nearest to P representing fatigue life of a measured R-ratio, e.g. R=10, or R=-1, or R=0.1.
- Measure the length b_1 on b between n_1 and n_2 .
- Calculate $b_2 = b_1 a_2 / a_1$
- Find the strain amplitude ϵ_{CLD} corresponding to point Q that lies on b at a distance b_2 away from the intersection of b and n_2 .
- Obtain the characteristic value of the expected number of cycles N^{exp} for ϵ_{Cal} using the measured characteristic S-N curve.

This geometrical description can be fairly easily put into a computer program.

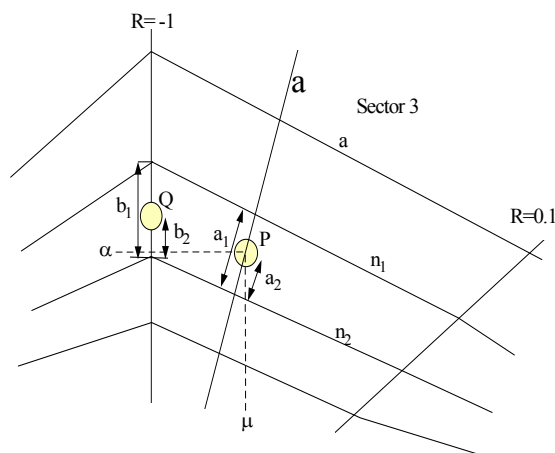

(Enlargement of the region with the points P and Q)

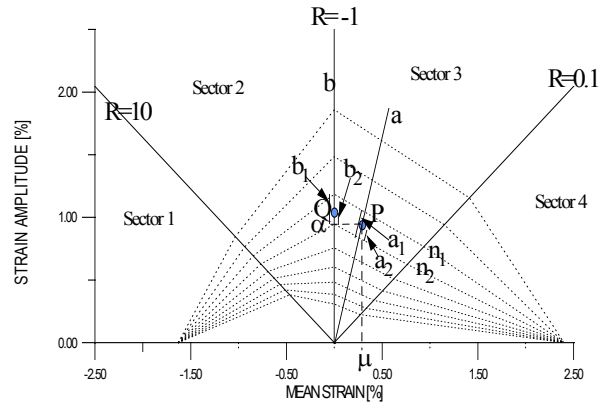

Figure 11 - A typical Constant Lifetime Diagram diagram.

This figure illustrates how the fatigue life for a strain amplitude α at mean μ (described by point P as an example) can be found.

---e-n-d---o-f---G-u-i-d-a-n-c-e---n-o-t-e---

504 The following design criterion for fatigue shall be used:

$$t_y \sum_{j=1}^N \frac{n^{actual} \{ \epsilon^j_{applied} \}}{n^{characterist} \{ \gamma_m \gamma_n \epsilon^j_{applied} \}} < 1$$

Where:

$n \{ \dots \}$ n as a function of...

$\epsilon_{applied}$ Local response of the structure to the strain condition applied including material factor

n^{actual} Number of cycles per year at a particular strain condition

$n^{characterist}$ Number of cycles to failure under a given design strain condition including material factor γ_m and consequence of failure factor γ_n

N The total number of strain conditions

j Index for strain condition

t_y Number of years for the fatigue evaluation (typically equal to the design life)

505 A stress based fatigue analysis may be used as an alternative by replacing strains with stresses.

506 If the structure is exposed to a known load sequence and the S-N curve has been obtained for that load sequence the Miner sum calculation is not required. If the load sequence changes, Miner sum calculations will be needed.

507 The fatigue analyses shall use material curves allowing for the expected operating environment of the wind turbine.

508 The selection of partial safety factors assumes that the fatigue loading is defined as a conservative mean value i.e., no uncertainty needs to be considered.

A600 Growth of fatigue damage

601 The growth of damage is a complicated process that is to be documented for the structure

under consideration with specific reference to test data. The simplified approach of assuming that the component is always completely saturated with damage may be used.

602 If a structural area accumulates fatigue damage, then the area is to be evaluated with and without that damage.

APPENDIX I – IMPACT DAMAGE (INFORMATIVE)

A100 General

101 Impact damage on FRP structure can produce little or no detectable surface damage; however result in severe sub-lamina damage. There are two possible effects of this impact damage on the structure:

- Introduce failure modes that reduce the load carrying capacity below the design load.
- Introduce minor failures that lead to further damage growth and possible failure.

102 It is difficult to achieve complete protection from impact damage, however to minimise impact damage all parts (e.g. vortex generators, stall strips) with an external surface vulnerable to impact damage should have a minimum thickness of 1.5mm.

A200 Detailed Considerations

201 When considering the effects of impact, the unintended failure mechanisms introduced due to impact (such as de-lamination) shall be evaluated.

202 The sensitivity of a structure to impact is to be determined by test. This can be done in two ways:

- The material or a small section shall be exposed to a relevant impact scenario.
- The entire component shall be exposed to a relevant impact scenario. The component is tested afterwards to demonstrate that it can still tolerate the critical loads.

203 The impact testing should verify that no unacceptable damage is introduced into the tested component. Once the tested component has been exposed to impact it should be carefully inspected to ensure that no unexpected failure mechanisms have occurred during the testing that may reduce the component's performance, in particular its long term performance. If the component is to be replaced after an impact, long term considerations do not have to be made.

Guidance note:

The maximum hail size to be considered is Ø 50 mm unless otherwise specified in the technical specification for the blade.

In the absence of specific guidance, an impact scenario of 8.13J with a 12.7mm diameter hemispherical head can be taken as a conservative approach.

---e-n-d--- o-f---G-u-i-d-a-n-c-e---n-o-t-e---

204 In impact testing the geometry of the impactor and the boundary conditions should represent a worst case for the blade. A change of

impactor geometry, boundary conditions, material properties or testing rate often changes the structural response completely.

205 It is to be demonstrated that the component can carry all relevant loads after impact until it can be taken out of service for repair or replacement. This can be done by analysis taking the observed impact damage into account, by testing, or a combination of analysis and testing.

206 Damages that will be realistically detected by the maintenance and inspection program can be excluded from testing.

207 The locations investigated for impact testing should be chosen carefully to represent worst case scenarios. In some cases a single point may be sufficient for testing. If multiple impacts are expected, then the tested component should be exposed to the expected number of impact events.

End