**Fibre-reinforced plastic composites —
Determination of the in-plane shear stress/
shear strain response, including the
in-plane shear modulus and strength,
by the $\pm 45^\circ$ tension test method**

*Composites plastiques renforcés de fibres — Détermination de la réponse
contrainte-déformation en cisaillement plan, module et résistance compris,
par essai de traction à $\pm 45^\circ$*



Contents	Page
1 Scope	1
2 Normative references	1
3 Principle	2
4 Definitions	2
5 Apparatus	2
6 Test specimens	4
7 Number of test specimens	4
8 Conditioning	5
9 Procedure	5
10 Calculation and expression of results	6
11 Precision	7
12 Test report	7
Annex	
A Specimen preparation	8

© ISO 1997

All rights reserved. Unless otherwise specified, no part of this publication may be reproduced or utilized in any form or by any means, electronic or mechanical, including photocopying and microfilm, without permission in writing from the publisher.

International Organization for Standardization
Case postale 56 • CH-1211 Genève 20 • Switzerland
Internet central@iso.ch
X.400 c=ch; a=400net; p=iso; o=isocs; s=central

Printed in Switzerland

Foreword

ISO (the International Organization for Standardization) is a worldwide federation of national standards bodies (ISO member bodies). The work of preparing International Standards is normally carried out through ISO technical committees. Each member body interested in a subject for which a technical committee has been established has the right to be represented on that committee. International organizations, governmental and non-governmental, in liaison with ISO, also take part in the work. ISO collaborates closely with the International Electrotechnical Commission (IEC) on all matters of electrotechnical standardization.

Draft International Standards adopted by the technical committees are circulated to the member bodies for voting. Publication as an International Standard requires approval by at least 75 % of the member bodies casting a vote.

International Standard ISO 14129 was prepared by Technical Committee ISO/TC 61, *Plastics*, Subcommittee SC 13, *Composites and reinforcement fibres*.

Annex A forms an integral part of this International Standard.

Introduction

This International Standard covers all current and future fibre-reinforced plastic composites which fail in the required manner. Harmonisation with the new tensile standard, ISO 527-5:1997, *Plastics — Determination of tensile properties — Part 5: Test conditions for unidirectional fibre-reinforced plastic composites*, has been achieved where relevant (e.g. document format, specimen size and related strains for modulus measurement).

The test is acceptable for modulus but there is concern over its use for the ultimate shear strength for high shear-elongation materials due to the high strain at failure with only a small further increase in load, fibre rotation and associated temperature rise. Therefore, the stress at a maximum shear strain of 5 % or less is used as the failure criterion. This failure criterion is also used in ASTM D 3518 (1995).

Fibre-reinforced plastic composites — Determination of the in-plane shear stress/shear strain response, including the in-plane shear modulus and strength, by the $\pm 45^\circ$ tension test method

1 Scope

1.1 This International Standard specifies a procedure for determining the in-plane shear stress/shear strain response, including the in-plane shear modulus and shear strength, of fibre-reinforced plastic composites by the $\pm 45^\circ$ tension test method.

1.2 The method is suitable for use with thermoset and thermoplastic matrix laminates made from unidirectional layers and/or fabrics including unidirectional fabrics, with the fibres oriented at $\pm 45^\circ$ to the specimen axis, where the lay-up is symmetrical and balanced about the specimen mid-plane.

NOTE — The method is not suitable for coarse fabrics.

1.3 As the test has been shown to be sensitive to the number and distribution of layers, comparisons should be undertaken using the same number of layers, which must be well distributed.

2 Normative references

The following standards contain provisions which, through reference in this text, constitute provisions of this International Standard. At the time of publication, the editions indicated were valid. All standards are subject to revision, and parties to agreements based on this International Standard are encouraged to investigate the possibility of applying the most recent editions of the standards indicated below. Members of IEC and ISO maintain registers of currently valid International Standards.

ISO 291:1997, *Plastics — Standard atmospheres for conditioning and testing*.

ISO 1268:1974, *Plastics — Preparation of glass fibre reinforced, resin bonded, low-pressure laminated plates or panels for test purposes*.¹⁾

ISO 2602:1980, *Statistical interpretation of test results — Estimation of the mean — Confidence interval*.

ISO 2818:1994, *Plastics — Preparation of test specimens by machining*.

ISO 5893:1993, *Rubber and plastics test equipment — Tensile, flexural and compression types (constant rate of traverse) — Description*.

¹⁾ Under revision.

3 Principle

A test specimen consisting of a strip of rectangular cross-section with the fibres oriented at $\pm 45^\circ$ to the specimen axis is loaded in tension. To determine the shear modulus the strains parallel and perpendicular to the specimen axis are measured. The test is terminated at $\gamma_{12} = 0,05$ if failure (excluding premature failure at or within the grip) has not occurred.

NOTE — Although this test method can establish shear stress/shear strain response well into the nonlinear region, the ultimate stress and strain values so obtained should be evaluated with the following caution. The material in the gauge section of this specimen is not in a state of pure shear, as normal stress components are present, even in the rotated ply coordinate system. It has been established that when a $\pm 45^\circ$ laminate is loaded in tension, normal stress components, though small, generally decrease the calculated ultimate stress and strain values of the material below the actual capability of the material, thus resulting in lower values of ultimate strength and strain than those obtained by more ideal methods, such as the tube torsion test.

4 Definitions

For the purposes of this International Standard, the following definitions apply:

4.1 in-plane shear stress, τ_{12} : The shear stress obtained by dividing the instantaneous load by twice the specimen cross-sectional area.

It is expressed in megapascals (MPa).

4.2 in-plane shear strength, τ_{12M} : The maximum in the shear stress prior to or at termination of the test at $\gamma_{12} = 0,05$.

It is expressed in megapascals (MPa).

4.3 shear strain, γ_{12} : The sum total of strain in the direction parallel and perpendicular to the specimen axis, i.e. $(\varepsilon_x - \varepsilon_y)$.

NOTE — ε_y has a negative sign when ε_x is positive.

4.4 in-plane shear (chord) modulus, G_{12} : The shear stress difference $(\tau_{12}'' - \tau_{12}')$ divided by the corresponding shear strain difference $(\gamma_{12}'' = 0,005 - \gamma_{12}' = 0,001)$ [see 10.3, equation (3)].

It is expressed in megapascals (MPa).

4.5 specimen coordinate axes: For the specimen shown in figure 1, the direction parallel to the specimen longitudinal axis is the "x" direction and the direction perpendicular to it is the "y" direction. The fibres are oriented at $\pm 45^\circ$ to these directions. The coordinate axes for a unidirectional reinforced composite material plate element are shown in figure 2.

5 Apparatus

5.1 Test machine

5.1.1 General

The machine shall conform to ISO 5893 as appropriate to the requirements given in 5.1.2 and 5.1.3.

5.1.2 Speed of testing

The speed of testing v shall be kept constant in accordance with ISO 5893.

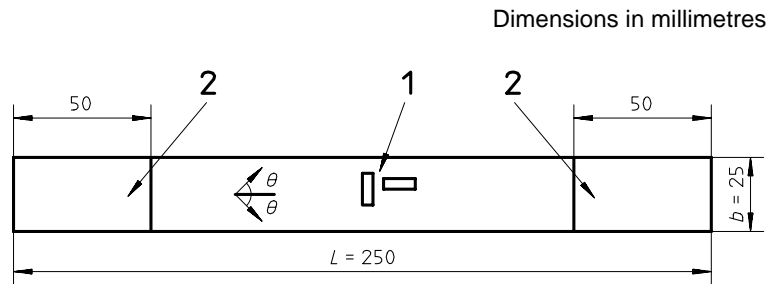
**Key**

- 1 Strain gauges
- 2 Tab
- θ Fibre angle ($= 45^\circ$)
- Specimen thickness $h = 2$ mm

Figure 1 — Fibre-reinforced plastic composite specimen showing fibre axes

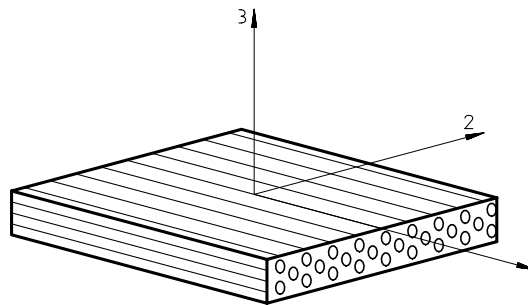

Figure 2 — Unidirectional reinforced composite plate element showing symmetry axes

5.1.3 Load indicator

The load indicator shall be such that the error in the indicated force is less than $\pm 1\%$ of the full-scale reading (see ISO 5893).

5.2 Strain measurement

The procedure requires the strain to be measured both parallel and perpendicular to the specimen axis. Strain gauges, applied as in figure 2, or extensometers shall be accurate to $\pm 1\%$ of the full scale. The gauges, surface preparation and bonding agents shall be chosen to give adequate performance on the subject materials, and suitable strain-recording equipment shall be employed.

5.3 Micrometer, or equivalent, capable of reading to 0,01 mm or less, and suitable for measuring the thickness h and width b of the test specimen.

The micrometer shall have contact faces appropriate to the surface being measured (i.e. flat faces for flat, polished surfaces and hemispherical faces for irregular surfaces).

6 Test specimens

6.1 Shape and dimensions

The specimen shall have a width of $25 \text{ mm} \pm 0,5 \text{ mm}$ and a length of 250 mm. Unless otherwise specified, the thickness shall be $2 \text{ mm} \pm 0,2 \text{ mm}$. The longitudinal edges of individual specimens shall be parallel to within 0,2 mm. The dimensions of the specimen are shown in figure 1.

For materials made with layers thicker than 0,125 mm, the laminate shall consist of 16 layers.

6.2 Preparation of specimens

6.2.1 General

A panel shall be prepared in accordance with ISO 1268 or another specified/agreed procedure with the required balanced and symmetrical $\pm 45^\circ$ fibre orientation.

Cut individual specimens or groups of specimens to the required size. Some parameters for machining are specified in ISO 2818. Further guidance on cutting specimens is given in annex A.

6.2.2 End tab material

Providing failure does not occur at or within the grip, unbonded tabs or no tabs may be used. If tabs are used, they shall be constructed from a cross-ply or fabric laminate made of glass-fibre/resin, or from the material under test, with the fibre axes of the fabric set at $\pm 45^\circ$ to the specimen axis. The tab material thickness shall be between 0,5 mm and 2 mm, with a tab angle of 90° (i.e. not tapered).

6.2.3 Application of end tabs

Bonded end tabs, if used, shall be applied to the specimen with a high-elongation adhesive, as shown in annex A.

NOTE — A similar procedure can be used for individual specimens or for a group of specimens.

6.2.4 Machining the specimens

The test specimens shall be cut with their axis at 45° to the fibre directions.

6.3 Checking the test specimens

The specimens shall be flat and free of twist. The surfaces and edges shall be free from scratches, pits, sink marks and flashes. The specimens shall be checked for conformity to these requirements by visual observation against straight-edges, squares and flat plates, and by measuring with micrometer callipers. Specimens showing measurable or observable departure from one or more of these requirements shall be rejected or machined to the required size and shape before testing.

7 Number of test specimens

7.1 At least five test specimens shall be tested. The number of measurements may be more than five if greater precision of the mean value is required.

It is possible to evaluate this by means of the confidence interval (95 % probability, see ISO 2602).

7.2 The results from test specimens that rupture at or inside the grips or end tabs shall be discarded and new specimens tested in their place.

8 Conditioning

Where applicable, condition the test specimens as specified in the standard for the material under test. In the absence of such information, select the most appropriate conditions from ISO 291, unless agreed otherwise by the interested parties.

9 Procedure

9.1 Test atmosphere

Where applicable, test the specimen as specified in the standard for the material under test. In the absence of such information, select the most appropriate conditions from ISO 291, unless agreed otherwise by the interested parties (e.g. for testing at elevated or reduced temperatures).

9.2 Measurement of specimen dimensions

Measure, at the mid-point of each test specimen, the width of the specimen to the nearest 0,1 mm and the thickness to the nearest 0,02 mm.

9.3 Specimen strain measurement

Apply extensometers or strain gauges along and perpendicular to the specimen axis (see figure 2) to measure the longitudinal (ϵ_x) and transverse (ϵ_y) strains, respectively.

9.4 Speed of testing

Where applicable, set the speed of testing as given in the standard for the material being tested. In the absence of this information, the speed of testing v shall be 2 mm/min.

9.5 Data collection

Monitor the load and both of the strain values throughout the test.

9.6 Test termination

Terminate the test at $\gamma_{12} = 0,05$ if failure has not occurred.

9.7 Maximum load

Record the failure load or the load at $\gamma_{12} = 0,05$.

9.8 Mode of failure

Check and record the mode of failure (see also 7.2).

10 Calculation and expression of results

10.1 Calculate the in-plane shear stress τ_{12} , expressed in megapascals, using the following equation:

$$\tau_{12} = \frac{F}{2bh} \quad \dots (1)$$

where

- F is the instantaneous load, in newtons;
- b is the width, in millimetres, of the test specimen;
- h is the thickness, in millimetres, of the test specimen.

10.2 Calculate the in-plane shear strength τ_{12M} , expressed in megapascals, using the following equation:

$$\tau_{12M} = \frac{F_m}{2bh} \quad \dots (2)$$

where F_m is the load, in newtons, at failure, or at $\gamma_{12} = 0,05$ if the test was terminated prior to failure.

10.3 Calculate the shear strain γ_{12} using the following equation:

$$\gamma_{12} = \varepsilon_x - \varepsilon_y \quad \dots (3)$$

where

- ε_x is the strain in the direction parallel to the specimen axis;
- ε_y is the strain in the direction perpendicular to the specimen axis.

10.4 Calculate the in-plane shear (chord) modulus G_{12} , expressed in megapascals, using the following equation (see figure 3):

$$G_{12} = \frac{\tau_{12}'' - \tau_{12}'}{\gamma_{12}'' - \gamma_{12}'} \quad \dots (4)$$

where

- τ_{12}' is the shear stress at a shear strain $\gamma_{12}' = 0,001$;
- τ_{12}'' is the shear stress at a shear strain $\gamma_{12}'' = 0,005$.

10.5 Calculate the arithmetic mean of the individual determinations and, if required, the standard deviation and the 95 % confidence interval of the mean value using the procedure given in ISO 2602.

10.6 Calculate the stresses and the modulus to three significant figures.

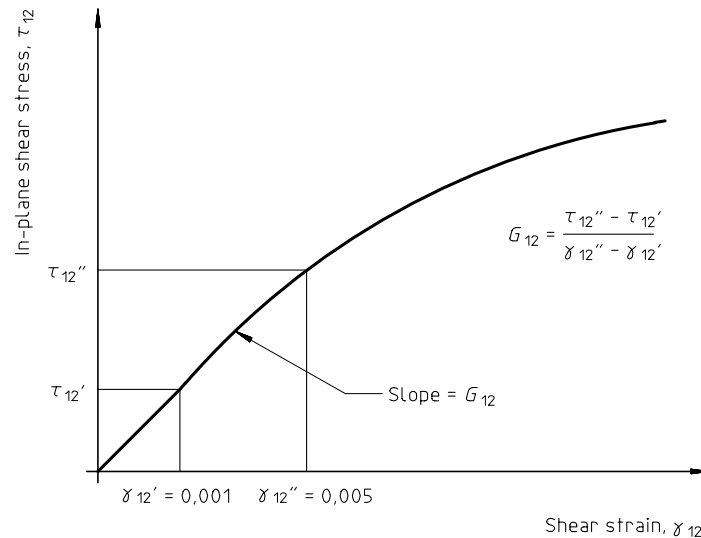

Figure 3 — Shear stress/shear strain diagram

11 Precision

The precision of this test method is not known because interlaboratory data are not available. When interlaboratory data are obtained, a precision statement will be added at the following revision. This method may not be suitable for use in specifications or in the case of disputed results as long as these data are not available.

12 Test report

The test report shall include the following information:

- a) a reference to this International Standard (i.e. ISO 14129);
- b) all details necessary for complete identification of the material tested, including type, source, manufacturer's code number, form and previous history, where these are known;
- c) the accuracy grading of the test machine (see ISO 5893);
- d) the method of preparing the test specimens;
- e) the dimensions of the test specimens;
- f) the number of specimens tested;
- g) the test conditions and the conditioning procedures, if applicable;
- h) the type of strain measurement used;
- i) the individual determinations, including shear stress/shear strain diagrams, if required;
- j) the mean values of the individual determinations;
- k) the standard deviations and the 95 % confidence intervals of the mean values, if required;
- l) the type(s) of failure obtained;
- m) a statement as to whether any test specimens were rejected and, if so, the reasons;
- n) any operation not specified in this International Standard, as well as any incident likely to have affected the results;
- o) the date of the test.

Annex A (normative)

Specimen preparation

A.1 Machining the specimens

In all cases, take the following precautions:

- Avoid working under conditions that would create a large build-up of heat in the test specimen; it is recommended that a coolant is used. If a liquid coolant is used, dry the test specimens immediately after machining.
- Check that all cut surfaces of the test specimen are free from machining defects.

A.2 Attachment of end tabs

A recommended method is as follows:

Cut out from the material under test a sheet having the length of the intended test specimens and of a width suitable for the number of specimens required. To form the end tabs, cut rectangular strips of the required width and length.

Attach the strips as follows (see figure A.1):

- a) If required, rub with fine abrasive paper or lightly blast with suitable grit all surfaces to which adhesive will be applied.
- b) Remove any dust and clean these surfaces with a suitable solvent.
- c) For bonding, use a high-elongation adhesive system, strictly following the manufacturer's instructions.

NOTE — It is recommended that a film adhesive with a thin carrier be used. The adhesive should preferably have a shear strength greater than 30 MPa. It is desirable that the adhesive used be flexible in nature with an elongation at break greater than that of the material under test.

- d) Keep the assembled parts at the pressure and temperature recommended by the adhesive manufacturer for the time recommended by the manufacturer.
- e) Superpose the strips at the ends, parallel with each other and normal to the length direction of the specimens.
- f) The sheets together with the strips constituting the end tabs are the test blanks ready for cutting into test specimens.

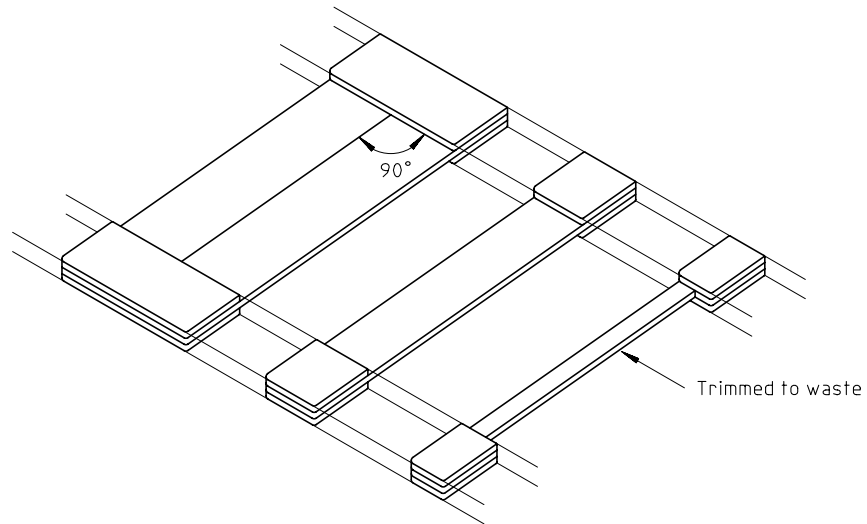

Figure A.1 — Tabbed panel for specimen preparation

ICS 83.120

Descriptors: plastics, reinforced plastics, tests, shear tests, determination, shear strength, shear modulus, test specimens.

Price based on 9 pages
