

QUALITY ASSURANCE





A stringent integrated quality control system established for Manufacturing, Inspection, Storage and Delivery procedures has resulted in the very high quality of TORAYCA products.



These quality standards are the inherited experience of Toray's synthetic fiber manufacturing processes for the past 70 years. This dedicated quality control system has been certified by today's aerospace manufacturers and has resulted in our Ehime, Japan facility achieving ISO 9000 registration. The Toray CFA plant in Alabama will be ISO 9000 registered in July of 2000.

A Certificate of Analysis (COA) will be issued to you on request. This to certify the fiber properties of TORAYCA and to state the lot average values for tensile strength, tensile modulus, ultimate strain at failure, density, yield, and sizing amount. These values are tested in accordance with Toray Test Methods. Please see Appendix for a copy of the test method procedures, including the sampling plan.

LABELING

TORAYCA carbon fiber is identified by labels attached to the Case and to the Bobbin. Examples of case labels from CFA, Toray Industries, and Soficar are shown below.

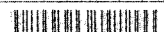
QUALITY CARBON FIBER	
'TORAY' TORAYCA	
TYPE	T700SC
FILAMENTS, etc.	12000-50C
	
GRADE K	NET wt. 24.0 kg (52.9 lb)
No. of BB 4	WT./BB 6.0 kg (13.2 lb)
	
LOT No.	A110021
CASE No.	0021009
	
600 K A 8 A 	
Toray Carbon Fibers America, Inc. Made in USA	

QUALITY CARBON FIBER	
'TORAY' TORAYCA	
TYPE	T300B
FILAMENTS, etc.	3000-40B
	
GRADE K	NET wt. 24.0 kg
WT./BB 2.0	kg/No. of BB 12
	
LOT No.	419011
CASE No.	9010953
	
200 K E 3 A 	
Toray Industries, Inc. Made in Japan	

QUALITY CARBON FIBER	
SOFICAR	TORAYCA MADE IN FRANCE
T800HB	
6000-40B	
GRADE	K
NET-WEIGHT	16.00 Kg
BOBBINS OF 1.00 Kg	NO. OF BOBBINS 16
LOT-NO	F219096
CASE-NO	9101291
SOFICAR S.A. MADE IN FRANCE	
	
3014 0010219096/01091	

QUALITY ASSURANCE

Manufacturing records of a particular TORAYCA carbon fiber product are easily traceable through Lot and Case numbers. Therefore, the Lot, Trace, and Case numbers are critical to the tracking of specific TORAYCA product history.

The designation contains the following information.

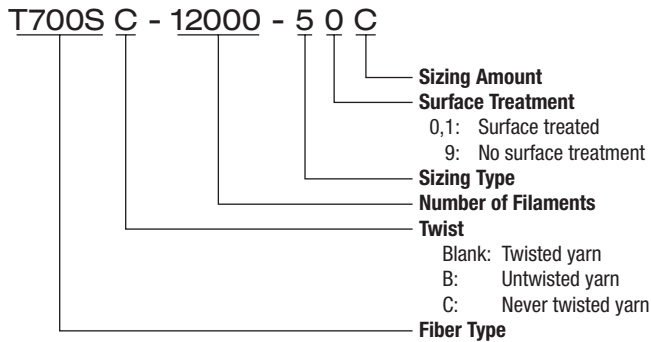

The lot number contains this information.

