**Gas cylinders — Refillable composite
gas cylinders and tubes — Design,
construction and testing —**

Part 1:

**Hoop wrapped fibre reinforced composite
gas cylinders and tubes up to 450 l**

*Bouteilles à gaz — Bouteilles à gaz rechargeables en matériau
composite et tubes — Conception, construction et essais —*

*Partie 1: Bouteilles à gaz frettées en matériau composite renforcé par
des fibres et tubes d'une contenance allant jusqu'à 450 l*





COPYRIGHT PROTECTED DOCUMENT

© ISO 2012

All rights reserved. Unless otherwise specified, no part of this publication may be reproduced or utilized in any form or by any means, electronic or mechanical, including photocopying and microfilm, without permission in writing from either ISO at the address below or ISO's member body in the country of the requester.

ISO copyright office
Case postale 56 • CH-1211 Geneva 20
Tel. + 41 22 749 01 11
Fax + 41 22 749 09 47
E-mail copyright@iso.org
Web www.iso.org

Published in Switzerland

Contents

Page

Foreword	iv
Introduction	v
1 Scope	1
2 Normative references	1
3 Terms and definitions	2
4 Symbols and units	3
5 Inspection and testing	4
6 Materials	4
6.1 Liner materials	4
6.2 Composite materials	4
7 Design and manufacture	5
7.1 General	5
7.2 Design submission	5
7.3 Manufacturing	6
8 Type approval procedure	7
8.1 General requirements	7
8.2 Prototype tests	7
8.3 New design	8
8.4 Design variants	9
8.5 Type approval test procedures and criteria	11
8.6 Failure of type approval tests	20
9 Batch inspection and testing	20
9.1 Liner	20
9.2 Failure of liner batch tests	21
9.3 Overwrap materials	21
9.4 Composite cylinder	22
9.5 Cylinder failure during type approval or batch testing	23
10 Cylinder marking	23
10.1 General	23
10.2 Additional markings	23
Annex A (informative) Example of design approval certificate	25
Annex B (informative) Specimen test reports	26
Bibliography	29

Foreword

ISO (the International Organization for Standardization) is a worldwide federation of national standards bodies (ISO member bodies). The work of preparing International Standards is normally carried out through ISO technical committees. Each member body interested in a subject for which a technical committee has been established has the right to be represented on that committee. International organizations, governmental and non-governmental, in liaison with ISO, also take part in the work. ISO collaborates closely with the International Electrotechnical Commission (IEC) on all matters of electrotechnical standardization.

International Standards are drafted in accordance with the rules given in the ISO/IEC Directives, Part 2.

The main task of technical committees is to prepare International Standards. Draft International Standards adopted by the technical committees are circulated to the member bodies for voting. Publication as an International Standard requires approval by at least 75 % of the member bodies casting a vote.

Attention is drawn to the possibility that some of the elements of this document may be the subject of patent rights. ISO shall not be held responsible for identifying any or all such patent rights.

ISO 11119-1 was prepared by Technical Committee ISO/TC 58, *Gas cylinders*, Subcommittee SC 3, *Cylinder design*.

This edition cancels and replaces ISO 11119-1:2002.

ISO 11119 consists of the following parts, under the general title *Gas cylinders — Refillable composite gas cylinders and tubes — Design, construction and testing*:

- *Part 1: Hoop wrapped fibre reinforced composite gas cylinders and tubes up to 450 l*
- *Part 2: Fully wrapped fibre reinforced composite gas cylinders and tubes up to 450 l with load-sharing metal liners*
- *Part 3: Fully wrapped fibre reinforced composite gas cylinders and tubes up to 450 l with non-load-sharing metallic or non-metallic liners*

The following part is under preparation:

- *Part 4: Fully wrapped fibre reinforced composite gas cylinders with load-sharing welded metal liners*

Introduction

The purpose of this International Standard is to provide a specification for the design, manufacture, inspection and testing of cylinders for worldwide usage. The objective is to balance design and economic efficiency against international acceptance and universal utility.

This International Standard aims to eliminate the concern about climate, duplicate inspection and restrictions currently existing because of lack of definitive International Standards and is not to be construed as reflecting on the suitability of the practice of any nation or region.

This part of ISO 11119 addresses the general requirements on design, construction and initial inspection and testing of pressure receptacles of the *Recommendations on the transport of dangerous goods: Model regulations* developed by the United Nations (Reference [15]).

Gas cylinders — Refillable composite gas cylinders and tubes — Design, construction and testing —

Part 1: Hoop wrapped fibre reinforced composite gas cylinders and tubes up to 450 l

1 Scope

This part of ISO 11119 specifies requirements for composite gas cylinders and tubes between 0,5 l and 450 l water capacity, for the storage and conveyance of compressed or liquefied gases.

This part of ISO 11119 applies to type 2 hoop wrapped cylinder or tube with a load-sharing metal liner and composite reinforcement on the cylindrical portion only.

This part of ISO 11119 is limited to cylinders and tubes with composite reinforcement of carbon fibre, aramid fibre or glass fibre (or a mixture thereof) within a matrix or steel wire to provide circumferential reinforcement.

Cylinders complying with this part of ISO 11119 have a minimum design life of 15 years.

This part of ISO 11119 does not address the design, fitting, and performance of removable protective sleeves.

NOTE ISO 11439^[5] applies to cylinders intended for use as fuel containers on natural gas vehicles and ISO 11623^[6] covers periodic inspection and re-testing of composite cylinders.

2 Normative references

The following referenced documents are indispensable for the application of this document. For dated references, only the edition cited applies. For undated references, the latest edition of the referenced document (including any amendments) applies.

ISO 3341, *Textile glass — Yarns — Determination of breaking force and breaking elongation*

ISO 6506-1, *Metallic materials — Brinell hardness test — Part 1: Test method*

ISO 6508-1, *Metallic materials — Rockwell hardness test — Part 1: Test method (scales A, B, C, D, E, F, G, H, K, N, T)*

ISO 6892-1, *Metallic materials — Tensile testing — Part 1: Method of test at room temperature*

ISO 7225, *Gas cylinders — Precautionary labels*

ISO 7866, *Gas cylinders — Refillable seamless aluminium alloy gas cylinders — Design, construction and testing*

ISO 9809-1, *Gas cylinders — Refillable seamless steel gas cylinders — Design, construction and testing — Part 1: Quenched and tempered steel cylinders with tensile strength less than 1 100 MPa*

ISO 9809-2, *Gas cylinders — Refillable seamless steel gas cylinders — Design, construction and testing — Part 2: Quenched and tempered steel cylinders with tensile strength greater than or equal to 1 100 MPa*

ISO 9809-3, *Gas cylinders — Refillable seamless steel gas cylinders — Design, construction and testing — Part 3: Normalized steel cylinders*

ISO 10618, *Carbon fibre — Determination of tensile properties of resin-impregnated yarn*

ISO 11119-1:2012(E)

ISO 11114-1, *Gas cylinders — Compatibility of cylinder and valve materials with gas contents — Part 1: Metallic materials*

ISO 13341, *Gas cylinders — Fitting of valves to gas cylinders*

ISO 13769, *Gas cylinders — Stamp marking*

EN 1964-3, *Transportable gas cylinders — Specification for the design and construction of refillable transportable seamless steel gas cylinders of water capacities from 0,5 litre up to and including 150 litres — Part 3: Cylinders made of seamless stainless steel with an R_m value of less than 1 100 MPa*

ASTM D7269, *Standard test methods for tensile testing of aramid yarns*

3 Terms and definitions

For the purposes of this document, the following terms and definitions apply. References to cylinders are to include composite tubes as appropriate.

3.1

aramid fibre

continuous filaments of aramid laid up in tow form

3.2

autofrettage

pressure application procedure which strains the metal liner past its yield point sufficient to cause permanent plastic deformation, and results in the liner having compressive stresses and the fibres having tensile stresses when at zero internal gauge pressure

3.3

batch

set of homogeneous items or material

NOTE The number of items in a batch can vary according to the context in which the term is used.

3.4

batch of liners

production quantity of up to 200 finished liners successively produced, plus units required for destructive testing of the same nominal diameter, length, thickness and design, from the same material cast and heat treated to the same conditions of temperature and time

3.5

batch of finished cylinders

production quantity of up to 200 finished cylinders successively produced by the same manufacturing process plus finished cylinders required for destructive testing, of the same nominal diameter, length, thickness and design

3.6

burst pressure

highest pressure reached in a cylinder during a burst test

3.7

carbon fibre

continuous filaments of carbon laid up in tow form

3.8

composite overwrap

combination of fibres (including steel wire) and matrix

3.9

dedicated gas service

service in which a cylinder is to be used only with a specified gas or gases

3.10**equivalent fibre or wire**

fibre or wire equivalent to a fibre or wire in a previously prototype tested cylinder

3.11**equivalent liner**

liner that has certified properties and performance so as to be a direct equivalent to a liner used in an already approved cylinder

3.12**exterior coating**

layers of material applied to the cylinder as protection or for cosmetic purposes

NOTE The coating can be clear or pigmented.

3.14**glass fibre**

continuous filaments of glass laid up in tow form

3.15**liner**

inner portion of the composite cylinder, comprising a metallic vessel, whose purpose is both to contain the gas and transmit the gas pressure to the fibres

3.16**matrix**

material that is used to bind and hold the fibres in place

3.17**steel wire**

steel wire wound under tension

3.18**thermoplastic material**

plastics capable of being repeatedly softened by increase of temperature and hardened by decrease of temperature

3.19**thermosetting material**

plastics that, when cured by the application of heat or chemical means, harden permanently into a substantially infusible and insoluble product

3.20**type 2 cylinder**

hoop wrapped cylinder with a load-sharing metal liner and composite reinforcement on the cylindrical portion only

3.21**working pressure**

settled pressure of a compressed gas at a reference temperature of 15 °C in a full gas cylinder

3.22**nominal outside diameter**

diameter of the cylinder specified by the manufacturer for the type approval including tolerances (e.g. ± 1 %)

4 Symbols and units

Symbols and their designations

p_b	burst pressure of finished cylinder	bar
p_h	test pressure	bar
p_{max}	maximum developed pressure at 65 °C	bar
p_w	working pressure	bar

5 Inspection and testing

This part of ISO 11119 is intended to be used under a variety of national regulatory regimes, but has been written so that it is suitable for use with the conformity assessment system of the *Recommendations on the transport of dangerous goods: Model regulations* developed by the United Nations (Reference [15]). Attention is drawn to requirements in specified relevant national regulations of the country (countries) where the cylinders are intended to be used that might override the requirements given in this part of ISO 11119.

To ensure that the cylinders conform to this part of ISO 11119, they shall be subject to inspection and testing in accordance with Clauses 6, 7, 8, and 9 by an inspection body (hereafter referred to as “the inspector”) authorized to do so. Example forms of certificates that can be used are shown in Annexes A and B.

Equipment used for measurement, testing, and examination during production shall be maintained and calibrated within a documented quality management system.

6 Materials

6.1 Liner materials

6.1.1 The liner materials shall conform in all relevant respects to the appropriate standard:

- a) seamless steel liners: ISO 9809-1, ISO 9809-2 or ISO 9809-3, as appropriate;
- b) seamless stainless steel liners: EN 1964-3;
- c) seamless aluminium alloy liners: ISO 7866.

Relevant sections are those covering materials, thermal treatments, neck design, construction and workmanship, and mechanical tests. This excludes the design requirements, since these are specified by the manufacturer for the design of the composite cylinder (see 7.2.2).

6.1.2 The materials used shall be of uniform and consistent quality. The composite cylinder manufacturer shall verify that each new batch of materials has the correct properties and is of satisfactory quality, and shall maintain records so that the cast of material and the heat treatment batch (where applicable) used for the manufacture of each cylinder can be identified.

6.1.3 The liner shall be manufactured from a metal or alloy suitable for containing the gas in accordance with ISO 11114-1.

6.1.4 When a neck ring is provided, it shall be of a material compatible with that of the cylinder, and shall be securely attached by a method appropriate to the liner material.

6.2 Composite materials

6.2.1 The overwrap filament materials shall be carbon fibre or aramid fibre or glass fibre (or any mixture thereof) or steel wire.

6.2.2 The matrix shall be a polymer suited to the application, environment, and intended life of the product.

6.2.3 The supplier of the filament material and the matrix system component materials or steel wire shall provide sufficient documentation for the composite cylinder manufacturer to be able to identify fully the batch of materials used in the manufacture of each cylinder.

6.2.4 The materials used shall be of uniform and consistent quality. The composite cylinder manufacturer shall verify that each new batch of materials has the correct properties and is of satisfactory quality, and maintain records from which the batch of materials used for the manufacture of each cylinder can be identified. A certificate of conformity from the material manufacturer is considered acceptable for the purposes of verification.

6.2.5 Batches of materials shall be identified and documented to the satisfaction of the inspector.

7 Design and manufacture

7.1 General

7.1.1 A hoop-wrapped composite gas cylinder shall comprise:

- a) an internal metal liner, which carries the total longitudinal load and a substantial circumferential load;
- b) either a composite overwrap formed by layers of continuous fibres in a matrix or a composite overwrap formed by steel wire reinforcement;
- c) an optional external protection system.

Where necessary, care shall be taken to ensure that there is no adverse reaction between the liner and the reinforcing fibre by the application of a suitable protective coating to the liner prior to the wrapping process.

7.1.2 Cylinders shall be designed with one or two openings along the central axis only. Threads shall extend completely through the neck or have sufficient threads to allow full engagement of the valve.

The cylinder can also include additional fittings (e.g. neck rings).

7.1.3 Example forms of certificates are shown in Annexes A and B.

7.2 Design submission

7.2.1 The design submission for each new cylinder shall include a detailed drawing, along with documentation of the design including manufacturing and inspection particulars as specified in 7.2.2, 7.2.3, and 7.2.4.

7.2.2 Documentation for the liner shall include (but not be limited to):

- a) material, including limits of chemical analysis;
- b) dimensions, minimum thickness, straightness, and out-of-roundness, with tolerances;
- c) process and specification of manufacture;
- d) heat treatment, temperatures, duration, and tolerances;
- e) inspection procedures (minimum requirements);
- f) material properties (mechanical properties requirements);
- g) minimum design burst pressure;
- h) dimensional details of valve threads and any other permanent features.

7.2.3 Documentation for the composite overwrap shall include (but not be limited to):

- a) fibre or wire material, specification, and mechanical properties requirements;
- b) fibre or wire construction, strand geometry and treatment;
- c) minimum composite thickness
- d) thermosetting matrix — specifications (including resin, curing agent and accelerator), and resin bath temperature where applicable;
- e) thermoplastic matrix system — main component materials, specifications and process temperatures;
- f) overwrap construction including the number of strands, number of layers, layer orientation, and tensioning of the fibre at wrapping (where applicable) ;
- g) curing process, temperatures, duration, and tolerances.

7.2.4 Documentation for the composite cylinder shall include (but not be limited to):

- a) nominal water capacity, in litres, under ambient conditions;
- b) dimensions with tolerances;
- c) list of intended contents, if intended for dedicated gas service;
- d) test pressure, p_h ;
- e) working pressure, p_w (if applicable, in which case it shall not exceed $0,67 \times p_h$);
- f) maximum developed pressure at 65 °C for specific dedicated gas(es), p_{max} ;
- g) minimum design burst pressure;
- h) design life in years, although cylinders with a test pressure of less than 60 bar shall have a non-limited design life;
- i) autofrettage pressure and approximate duration (where applicable);
- j) tensioning of the fibre or wire at wrapping (where applicable);
- k) nominal mass of the finished composite cylinder, including tolerances;
- l) details of components which are permanently attached and form part of the qualified design (neck rings, protective boots, etc.).

7.3 Manufacturing

7.3.1 The liner shall be manufactured in accordance with the manufacturer's design (see 7.2.2) and the International Standard for the relevant metallic material (as listed in 6.1.1).

7.3.2 The composite cylinder shall be fabricated from a load-sharing liner overwrapped with layers of continuous fibres in a matrix or steel wire applied under controlled tension wrapping to develop the design composite thickness as specified in 7.2.3.

Liners can be stripped and re-wound provided that the overwrap has not been cured. The liner shall not be overwrapped if it has been damaged or scored by the stripping process.

7.3.3 After wrapping is completed, the composite shall be cured (if appropriate) using a controlled temperature profile as specified in the documentation in 7.2.3. The maximum temperature shall be such that the mechanical properties of the liner material are not adversely affected.

7.3.4 If cylinders are subjected to an autofrettage operation, the autofrettage pressure and duration shall be as specified in the documentation in 7.2.4. The manufacturer shall demonstrate the effectiveness of the autofrettage by appropriate measurement technique(s) acceptable to the inspector.

7.3.5 If cylinders are subjected to a prestressing or fibre tensioning during wrapping in order to actively change the final stresses in the finished cylinder, the level of stress shall be as specified in the documentation in 7.2.4 and levels of stress of tensioning shall be recorded or monitored.

8 Type approval procedure

8.1 General requirements

Each new cylinder design shall be submitted by the manufacturer to the inspector. The type approval tests detailed in 8.2 shall be performed, under the supervision of the inspector, on each new cylinder design or design variant.

8.2 Prototype tests

8.2.1 A minimum of 30 cylinders that are representative of the new design shall be made available for prototype testing. Upon successful completion of all prototype tests, the remaining untested cylinders from the prototype qualification batch can be used for service.

8.2.2 If, for special applications, the total number of cylinders required is less than 30, sufficient cylinders shall be made to complete the prototype tests required, in addition to the production quantity. In this case, the approval validity shall be limited to this batch only.

For a limited design change (design variant), in accordance with Table 1, a reduced number of cylinders shall be selected by the inspector.

8.2.3 The batch of liners, prior to being wrapped, shall conform to the design requirements and shall be inspected and tested in accordance with 9.1. Where specified in Table 1, one liner shall be selected and subjected to a burst test in accordance with 8.5.3.

8.2.4 The composite material(s), prior to the cylinders being wrapped, shall conform to the design requirements and shall be tested in accordance with 9.3.

8.2.5 Tests for a new cylinder design shall be supervised by an inspector and shall consist of:

- a) hydraulic proof pressure test, in accordance with 8.5.1, or hydraulic volumetric expansion test, in accordance with 8.5.2;
- b) liner burst test in accordance with 8.5.3;
- c) cylinder burst test in accordance with 8.5.4;
- d) ambient cycle test, in accordance with 8.5.5;
- e) environmental cycle test, in accordance with 8.5.6;
- f) torque test in accordance with 8.5.10;

8.2.6 Tests that are optional depending upon the design and intended use of the cylinder are:

- a) high velocity impact (gunfire) test, in accordance with 8.5.7 (mandatory for military applications);
- b) fire resistance test, if a pressure relief device is fitted to prevent failure in case of fire in service, in accordance with 8.5.8;

- c) salt water immersion test, in accordance with 8.5.9 (mandatory for underwater applications);
- d) environmentally assisted stress rupture, in accordance with 8.5.11;
- e) drop test for cylinders with test pressure less than 60 bar, in accordance with 8.5.12.

8.2.7 For approval of a design variant as specified in 8.4, it is only necessary to carry out the tests as stated in Table 1 under supervision of the inspector. A cylinder approval by a reduced series of tests shall not be used as a basis for a second design variant approval with a reduced set of tests (i.e. multiple changes from an approved design are not permitted), although individual test results can be used as applicable (see 8.4.2).

8.2.8 Tests can be combined such that one cylinder can be used for more than one test. For example, the cylinder burst test in the drop test (8.5.12) can be used to satisfy the requirement of the burst test (8.5.4).

8.2.9 If the results of the above prototype tests are satisfactory, the inspector shall issue a design approval certificate, a typical example of which is given in Annex A.

8.2.10 After completion of the tests, the cylinders shall be destroyed or made incapable of holding pressure.

8.3 New design

8.3.1 After approval, no alteration shall be made to the design or to the method of manufacture without requalification

8.3.2 A new cylinder design requires full type approval testing. A cylinder shall be considered to be of a new design compared with an existing approved design if the method of manufacture or cylinder design has changed to a significant extent. Examples are given in a) to g).

- a) It is manufactured in a different factory. A relocation of a factory does not require a new cylinder design approval provided all equipment and procedures remain the same as for the original design approval.
- b) It is manufactured by a process that is significantly different from the process used in the design type approval. A significant change is regarded as one that would give rise to measurable change in the performance of the liner and/or finished cylinder. The inspector determines when a change in process or design or manufacture is significantly different from the original qualified design.
- c) The nominal outside diameter had changed more than 50 % from the qualified design.
- d) A fibre of the same specification classification and mechanical properties, but with a different linear density shall not be considered a new fibre type. Minor changes in the wrapping pattern shall not be considered to be a new design.
- e) The cylinder is manufactured with a new fibre type. A fibre shall be considered to be of a new fibre type when:
 - 1) the fibre is of a different classification (e.g. glass, aramid or carbon);
 - 2) the fibre is produced from a different precursor [e.g. polyacrylonitrile (PAN) or pitch for carbon];
 - 3) The fibre is not equivalent [see 8.4.1 i)] to the fibre in the original design.
- f) The matrix materials (i.e. resin, curing agent, accelerator) are different and not chemically equivalent to the original design.
- g) The test pressure has increased more than 60 % from the qualified design.

8.3.3 A cylinder shall also be considered to be of a new design compared with an existing approved design if the method of liner manufacture or design has changed to a significant extent. Examples are given in a) to c).

- a) It is manufactured in a different factory. A relocation of factory does not require a new cylinder design approval provided all equipment and procedures remain the same as for the original design approval.
- b) It is manufactured from a material of different composition or composition limits from that used in the original type tests.
- c) The material properties are outside the original design limits.

8.4 Design variants

8.4.1 For cylinders that are variants of another design, a reduced type approval testing programme is required as specified in Table 1. A cylinder shall be considered to be a design variant if changes are limited to items a) to k).

- a) The nominal length of the cylinder has changed by more than 5 %.
- b) The nominal outside diameter has changed by 50 % or less.
- c) The autofrettage pressure has changed by more than 5 % or 10 bar, whichever is the lower.
- d) There is a change in the design test pressure up to and including 60 %.

NOTE Where a cylinder is to be used and marked for a lower test pressure than that for which design approval has been given, it is not to be deemed to be a new design or design variant.

- e) The base profile and/or base thickness of the liner has changed relative to the cylinder diameter and minimum wall thickness.
- f) The minimum wall thickness of the liner has changed by more than 5 %.
- g) There have been changes to the composite thickness or wrap pattern other than the changes necessary to accommodate the changes of diameter and/or length.
- h) Matrix materials (i.e. resin, curing agent, accelerator) are different but are chemically equivalent to the original design.
- i) When equivalent overwrapping fibres or wire are used.

Equivalent fibres and wire are manufactured from the same nominal raw materials, using the same process of manufacture and having the same physical structure and the same nominal physical properties, and where the average tensile strength and modulus is within ± 5 % of the fibre or wire properties in an approved cylinder design. Carbon fibres made from the same precursor can be equivalent. Aramid, carbon and glass fibres are not equivalent.

NOTE Where a new equivalent fibre or wire has been prototype tested for an existing design, all the manufacturer's existing prototype tested designs are regarded as prototype tested with the new fibre or wire without the need for any additional prototype testing.

- j) When an equivalent liner is used:

equivalent liners are manufactured from the same nominal raw materials, using the same process of manufacture and having the same physical structure and where the average tensile strength and modulus is within ± 5 % of the approved cylinder design;

the equivalent liner material shall be subjected to the material tests specified in 9.1.3 and the liner burst test specified in 8.5.3 and in both cases shall meet the minimum requirements specified in 7.2.2;

where a new equivalent liner has been prototype tested for an existing design, all the manufacturer's existing prototype tested designs are regarded as prototype tested with the new liner without the need for any additional prototype testing.

Table 1 — Type approval tests

Test No.	Test	New design	Nominal length		Nominal diameter		Design variant changes									
			>5 % and ≤50 %	>50 %	≤20 %	>20 % and ≤50 %	Equi-valent liners	Equi-valent matrix materials	Liner thickness change	Test pressure ≤20 %	Test pressure >20 % and ≤60 %	Fibre or wire thick or liner base form	Equi-valent fibre or wire	Thread	Auto-frettage	
9.1	Liner material test							x								
9.4	Composite material tests													x		
8.5.1-2	Hydraulic pressure	x	x	x	x	x	x	x	x	x	x	x	x	x		x
8.5.3	Liner burst	x	x	x	x	x	x	x								
8.5.4	Cylinder burst	x	x	x	x	x	x	x	x	x	x	x	x	x		x
8.5.5	Ambient cycle	x	x	x	x	x	x	x	x	x	x	x	x	x		x
8.5.6	Environmental cycle	x														
8.5.7	High velocity impact (gunfire) ^a	x				x ^b			x ^c		x					
8.5.8	Fire resistance ^a	x				x			x ^c		x					
8.5.9	Salt water ^a	x														
8.5.10	Torque test ^f	x													x	
8.5.11	Stress rupture test ^a	x														x ^e
8.5.12	Drop test ^d	x		x		x			x							

a Optional test required according to the design and intended use of the cylinder of an approved design only.

b Test to be conducted for reduction in diameter only.

c Test to be conducted if thickness decreases only.

d Test to be conducted on cylinders with test pressure below 60 bar only.

e For an increase in autofretage pressure of more than 15 %.

f When a cylinder design has only a different thread compared to the torque test in accordance with 8.5.10, shall be performed.

k) When the cylinder thread has changed:

when a cylinder design has only a different thread compared to an approved design, only the torque test, in accordance with 8.5.10, shall be performed.

8.4.2 A cylinder approval by a reduced series of tests (a “design variant”) shall not be used as a basis for a second design variant approval with a reduced set of tests (i.e. multiple changes from an approved design are not permitted). If a test has been conducted on a design variant (A) that falls within the design change for a second variant (B), then the result for (A) can be applied to the new design variant (B) test programme. However, design variant (A) cannot be used as the reference for determining the testing required for any new design variant.

8.4.3 Where a design variant involves more than one parameter change, all the tests required by those parameter changes shall be performed once only.

8.4.4 The inspector shall determine the level of reduced testing if not defined in Table 1, but a fully approved design shall always be used as a reference for the new design variant (i.e. new design variants shall not be approved by reference only to a previous design variant).

8.5 Type approval test procedures and criteria

8.5.1 Proof pressure test

8.5.1.1 Procedure

When carrying out the pressure test, a suitable fluid (normally water) shall be used as the test medium. This test requires that the pressure in the cylinder be increased gradually and regularly until the test pressure, p_h , is reached. The cylinder test pressure shall be held for at least 30 s with the cylinder isolated from the pressure source, during which time there shall be no decrease in the recorded pressure or evidence of any leakage. Adequate safety precautions shall be taken during the test.

If leakage occurs in the piping or fittings, the cylinders shall be retested after repairing such leakages.

Where cylinders are subjected to autofrettage, the hydraulic proof pressure test can immediately follow the autofrettage process.

The limit deviation on attaining test pressure shall be $(p_h + 3) \%$ or $(p_h + 10)_0$ bar, whichever is the lower. Pressure gauges with the appropriate accuracy shall be used.

All internal surfaces of cylinders shall be dried (to ensure no free water) immediately after testing:

Alternatively a pneumatic pressure test can be used provided that appropriate measures are taken to ensure safe operation and to contain any energy that can be released, which is considerably more than in the hydraulic test.

8.5.1.2 Criteria

The cylinder shall be rejected if there are leaks, failure to hold pressure or visible permanent deformation after the cylinder is depressurized.

NOTE Cracking of resin is not necessarily a sign of permanent deformation.

8.5.2 Hydraulic volumetric expansion test

8.5.2.1 Procedure

When carrying out the pressure test, a suitable fluid (e.g. normally water) shall be used as the test medium. This test requires that the pressure in the cylinder be increased gradually and regularly until the test pressure,

p_h , is reached. The cylinder test pressure shall be held for at least 30 s with the cylinder isolated from the pressure source, during which time there shall be no decrease in the recorded pressure or evidence of any leakage. Adequate safety precautions shall be taken during the test.

If leakage occurs in the piping or fittings, the cylinders shall be retested after repairing such leakages.

The total volumetric expansion of each cylinder under the test pressure, p_h , and the permanent volumetric expansion of the cylinder after the pressure is released shall be recorded. The elastic expansion (i.e. total expansion less permanent expansion) under test pressure shall then be established for each cylinder.

Where cylinders are subjected to autofrettage, the hydraulic volumetric expansion test can immediately follow the autofrettage process.

The limit deviation on attaining test pressure shall be $(p_h + 3) \%$ or $(p_h^{+10}_0)$ bar, whichever is the lower.

All internal surfaces of cylinders shall be dried (to ensure no free water) immediately after testing.

8.5.2.2 Criteria

The cylinder shall be rejected if:

- a) there are leaks or failure to hold pressure;
- b) there is permanent expansion (i.e. volumetric expansion after the pressure has been released) in excess of 5 % of the total expansion.

8.5.3 Liner burst test

8.5.3.1 Procedure

One liner shall be tested hydraulically to destruction by pressurizing at a rate of no more than 5 bar/s. The test shall be carried out under ambient conditions.

The parameters that shall be monitored and recorded are:

- a) burst pressure;
- b) the number of pieces;
- c) description of failure;
- d) pressure–time curve or pressure–volume curve.

8.5.3.2 Criteria

The minimum burst pressure p_{bl} , shall be $\geq 0,85 \times p_h$, where p_h is the cylinder design test pressure, and shall be not less than the minimum burst pressure specified in the design submission (7.2.2). Failure shall initiate in the liner side wall and the liner shall remain in one piece.

8.5.4 Cylinder burst test

8.5.4.1 Procedure

Three cylinders shall be hydraulically tested to destruction by pressurizing at a rate of no more than 10 bar/s. The test shall be performed under ambient conditions. Prior to the commencement of the test, it shall be ensured that no air is trapped within the system.

The parameters that shall be monitored and recorded are:

- a) burst pressure;

- b) description of failure;
- c) pressure–time curve or pressure–volume curve.

8.5.4.2 Criteria

- a) The burst pressure shall exceed the minimum design burst pressure specified by the cylinder manufacturer (see 7.2.4).
- b) The burst pressure, p_b , for cylinders with carbon fibre reinforcement shall be not less than $1,67 \times p_h$, where p_h is the test pressure.
- c) The burst pressure, p_b , for cylinders with aramid or glass fibre reinforcement shall be not less than $2,00 \times p_h$.
- d) For cylinders with test pressure <60 bar, the burst pressure, p_b , shall be not less than $2 \times p_h$ of the composite cylinder design.

8.5.5 Ambient cycle test

8.5.5.1 For cylinders with test pressure equal to or greater than 60 bar

8.5.5.1.1 General

Where a cylinder is intended for use only with one or more specific gases, the design can be designated for dedicated gas use. The gases permitted in the cylinder shall be identified clearly on the cylinder label (see 10.2).

8.5.5.1.2 Procedure

Two cylinders shall be subjected to a hydraulic pressure cycle test to test pressure, p_h , for unspecified gas service or maximum developed pressure at 65 °C, p_{max} , for the dedicated gas which has the greatest developed pressure.

The test shall be performed using a non-corrosive fluid under ambient conditions, subjecting the cylinders to successive reversals at an upper cyclic pressure that is equal to the hydraulic test pressure, p_h , or maximum developed pressure at 65 °C, p_{max} , as appropriate.

The value of the lower cyclic pressure shall not exceed 10 % of the upper cyclic pressure, but shall have an absolute maximum of 30 bar. The frequency of reversals of pressure shall not exceed 0,25 Hz (15 cycle/min). The temperature on the outside surface of the cylinder shall not exceed 50 °C during the test.

The parameters that shall be monitored and recorded are:

- a) temperature of the cylinder;
- b) number of cycles achieving upper cyclic pressure;
- c) minimum and maximum cyclic pressures;
- d) cycle frequency;
- e) test medium used;
- f) mode of failure, if appropriate.

8.5.5.1.3 Criteria

Both the cylinders shall withstand N pressurization cycles to test pressure, p_h , or N_d pressurization cycles to maximum developed pressure, p_{max} , without failure by burst or leakage, where:

$$N = t \times 250 \text{ cycle/year of design life};$$

$$N_d = t \times 500 \text{ cycle/year of design life;}$$

where *t* is the number of years of design life, which shall be a whole number, not less than 10.

The test shall continue for a further *N* or *N_d* cycles, or until the cylinder fails by leakage, whichever is the sooner. In either case, the cylinder shall be deemed to have passed the test. However, if failure during this second part of the test is by bursting, then the cylinder shall have failed the test (see Table 2).

If the cylinder is designed to pass 12 000 hydraulic cycles to test pressure or 24 000 cycles to maximum developed pressure, and achieves this level consistently in the test it shall not be necessary to limit the design life of the cylinder.

Table 2 — Criteria for ambient cycle test

	1st part	2nd part
Number of cycles	0 to <i>N</i>	<i>N</i> to 2 <i>N</i> but 2 <i>N</i> no more than 12 000
	0 to <i>N_d</i>	<i>N_d</i> to 2 <i>N_d</i> but 2 <i>N_d</i> no more than 24 000
Criteria	No leakage/burst = Pass	
	No leakage or burst	Leakage = Pass
	Pass 1st part	Burst = Fail

8.5.5.2 For cylinders with test pressure less than 60 bar

8.5.5.2.1 Procedure

Two cylinders shall be subjected to a hydraulic pressure cycle test to test pressure.

The test shall be performed using a non-corrosive fluid under ambient conditions, subjecting the cylinders to successive reversals at an upper cyclic pressure that is equal to the hydraulic test pressure, *p_h*.

The value of the lower cyclic pressure shall not exceed 10 % of the upper cyclic pressure. The frequency of reversals of pressure shall not exceed 0,25 Hz (15 cycle/min). The temperature on the outside surface of the cylinder shall not exceed 50 °C during the test.

The parameters that shall be monitored and recorded are:

- a) temperature of the cylinder;
- b) number of cycles achieving upper cyclic pressure;
- c) minimum and maximum cyclic pressures;
- d) cycle frequency;
- e) test medium used;
- f) mode of failure, if appropriate.

8.5.5.2.2 Criteria

Both the cylinders shall withstand 12 000 pressurization cycles to test pressure, *p_h*. If the cylinder is designed to pass 12 000 hydraulic cycles to test pressure and achieves this level consistently in the test, it shall not be necessary to limit the design life of the cylinder.

8.5.6 Environmental cycle test

8.5.6.1 General

Perform the tests in this section in an environmental chamber. One cylinder, without paint or removable protective coating and/or casing shall be tested.

8.5.6.2 Procedure

The cylinder to be tested shall be filled at the ambient atmospheric pressure using a suitable medium (e.g. a non-corrosive fluid) such that its properties do not degrade from those at ambient temperature when used at the test temperature extremes.

Condition cylinder and contained pressurizing medium for 48 h at atmospheric pressure, at a temperature between 60 °C and 70 °C and at a relative humidity greater than or equal to 90 %. The intent of this requirement can be met by spraying with a continuous fine spray or mist of water in a chamber held between 60 °C and 70 °C.

Then install the cylinder to be tested in an environmental chamber capable of meeting the temperature and humidity requirements for the test.

Connect the cylinder to be tested to a source of pressure, mounted externally to the environmental chamber, which is capable of meeting the cylinder pressure cycling requirements.

Seal the cylinder in the environmental test chamber and follow a) to c).

- a) Carry out the hot cycle test phase starting with the cylinder at ambient temperature, pressure, and humidity. Change the test chamber environment until a cylinder surface temperature of between 60 °C and 70 °C is achieved. Cycle the internal pressure between $0,67 \times p_h$ and less than 10 % of working pressure (6.67 % of test pressure) for 5 000 cycles using the external pressurizing medium supplied at ambient temperature.

The cycling frequency shall not exceed 5 cycle/min.

During the test, the cylinder surface temperature shall be maintained at between 60 °C and 70 °C (e.g. by regulating the environmental chamber parameters and the pressure cycling frequency).

Once the required number of pressure cycles have been completed, release the cylinder internal pressure and stabilize its temperature at approximately 20 °C.

- b) Carry out the cold cycle test phase starting the cylinder at ambient atmospheric temperature, pressure, and humidity. Change the test chamber environment until a cylinder surface temperature of between –50 °C and –60 °C is achieved. Cycle the internal less than 10 % of working pressure (6,67 % of test pressure) and $0,67 \times p_h$ for 5 000 cycles using the external pressurizing medium supplied at ambient temperature.

The cycling frequency shall not exceed 5 cycle/min.

During the test, the cylinder surface temperature shall be maintained at between –50 °C and –60 °C (e.g. by regulating the environmental chamber parameters and the pressure cycling frequency).

Once the required number of pressure cycles have been completed, release the cylinder internal pressure and stabilize its temperature at approximately 20 °C.

- c) Carry out a burst test in accordance with the requirements of 8.5.4.

The parameters that shall be monitored and recorded are:

- 1) the cylinder surface temperature throughout the test;
- 2) the test chamber humidity;
- 3) the cylinder pressurization medium used;
- 4) the number of pressure cycles completed (a complete cycle will have achieved the required test pressure, e.g. $p_{max d}$);

- 5) the minimum and maximum cyclic pressures achieved for each test cycle;
- 6) the pressure cycle frequency;
- 7) the parameters specified in 8.5.4.

8.5.6.3 Criteria

- a) The burst pressure shall be greater than 85 % of the minimum design burst pressure.
- b) The burst pressure, p_b , for cylinders with carbon fibre reinforcement shall be not less than $1,5 \times p_h$.
- c) The burst pressure, p_b , for cylinders with aramid fibre reinforcement shall be not less than $1,7 \times p_h$.
- d) The burst pressure, p_b , for cylinders with glass fibre reinforcement shall be not less than $1,7 \times p_h$.

8.5.7 High velocity impact (gunfire) test

8.5.7.1 General

This test is mandatory for military applications, and is optional for other uses.

8.5.7.2 Procedure

One cylinder shall be filled to working pressure ($0,67 \times p_h$) with air or nitrogen or the gas to be contained.

WARNING — Appropriate measures shall be taken to ensure safe operation and to contain any energy that can be released.

The cylinder shall be positioned in such a way that the point of impact of the projectile is in the cylinder side wall at a nominal angle of 45° and such that the bullet would also exit through the cylinder side wall.

Cylinders with diameter of above 120 mm shall be impacted by a 7,62 mm (0,3 calibre) armour-piercing projectile (of length between 37 mm and 51 mm) with a nominal speed of 850 m/s. The bullet shall be fired from a distance of not more than 45 m. The cylinder shall be safely vented before removal from the test site.

Cylinders with diameter of 120 mm and below shall be impacted by a 5,6 mm armour-piercing (or similar) bullet with a nominal speed of 850 m/s. The bullet shall be fired from a distance of not more than 45 m. The cylinder shall be safely vented before removal from the test site.

The parameters that shall be monitored and recorded are:

- a) type of projectile;
- b) initial pressure;
- c) description of failure;
- d) approximate size of the entrance and exit openings.

8.5.7.3 Criteria

The cylinder shall remain in one piece. If a cylinder is not penetrated by the above projectile, then the cylinder will have passed the test.

8.5.8 Fire resistance test

8.5.8.1 General

This test is mandatory if pressure relief devices (PRDs) are fitted to prevent failure in case of fire in service and is optional for other uses.

8.5.8.2 Procedure

Two cylinders shall be fitted with either:

- a) the valves and PRDs intended for use (if known); or
- b) a valve fitted with bursting disc set to operate at between p_h and $1,15 \times p_h$.

If the test is conducted with the PRDs and valve intended for use in service [i.e. option a)], the specification of the valve and PRDs shall be marked on the design drawing and the approval certificate.

The cylinder shall be charged with either air or nitrogen or the gas intended for use to the working pressure ($0,67 \times p_h$).

A uniform fire source of 1,65 m length shall be used that is capable of enveloping the entire diameter of the cylinder, when in the horizontal position, and producing a temperature ≥ 590 °C, measured 25 mm below the cylinder within 2 min.

Any fuel can be used for the fire source provided it supplies uniform heat sufficient to maintain the specified test temperatures until the cylinder is vented. The selection of a fuel should take into consideration pollution concerns.

The cylinders shall be tested in both the vertical or horizontal position as follows.

Vertical. One cylinder shall be placed in an upright position (valve uppermost for cylinders with one valve and PRD), with the lowest part of the cylinder approximately 0,1 m from the top of the firewood, in the case of a wood fire, or 0,1 m from the surface of the liquid in a fuel-based fire. The relief device shall be shielded from direct flame impingement.

Horizontal. One cylinder shall be placed in a horizontal position with the centre of the fire at the mid-point of the cylinder and with the lowest part of the cylinder approximately 0,1 m from the top of the firewood, in the case of a wood fire, or 0,1 m from the surface of the liquid in a fuel-based fire. The relief device shall be shielded from direct flame impingement.

The cylinder shall be exposed to the fire until it has vented to a pressure less than 7 bar. After the test, the cylinder shall be rendered unserviceable.

The parameters that shall be monitored and recorded are:

- a) type and characteristics of pressure relief device;
- b) initial pressure;
- c) location of leak;
- d) temperature;
- e) time.

8.5.8.3 Criteria

The cylinder shall not burst during a period of 2 min from the start of the fire test. It can vent through the pressure relief device or leak through the cylinder wall or other surfaces.

NOTE This test does not imply that only one pressure relief device assembly provides fire protection for the valve and PRD system.

8.5.9 Salt water immersion test

8.5.9.1 General

This test is mandatory for all cylinders intended for underwater applications and for cylinders using steel wire reinforcement, but is not required for other applications.

8.5.9.2 Procedure

The cylinders shall be unpainted, but otherwise finished as for the intended application. The liner can be painted or protected from corrosion in any manner that is included in the design submission.

a) Immersion period.

Two closed unpressurized cylinders shall be immersed for a period of between 1 h and 2 h in an aqueous solution containing 35 g/l of sodium chloride at a temperature not less than 20 °C.

After 2 h the hydraulic pressure of the cylinder shall be increased to and maintained at $0,67 \times p_h$ for not less than 22 h.

b) Drying period

The pressurized cylinders shall then be removed from the salt water and subjected to natural drying conditions in ambient atmosphere for not less than 22 h.

During this drying-out period, the cylinders shall be pressurized. The hydraulic pressure of the cylinder shall be increased to and maintained at $0,67 \times p_h$ for not less than 2 h. Pressure shall then be released.

Repeat the cycle consisting of these two periods, a) and b), 45 times.

On completion of these tests, one of the two cylinders shall be submitted to hydraulic pressure to burst, in accordance with 8.5.4, and the other cylinder submitted to pressure cycling in accordance with 8.5.5.

The parameters that shall be monitored and recorded are:

- 1) temperature of the solution, at least once a day;
- 2) filling pressure;
- 3) duration of immersion;
- 4) parameters specified in 8.5.4;
- 5) parameters specified in 8.5.5.

8.5.9.3 Criteria

- a) The burst pressure, p_b , shall be not less than $1,67 \times p_h$ of the composite cylinder design.
- b) The second cylinder shall satisfy the criteria for the ambient cycle test, 8.5.5.

8.5.10 Torque test

8.5.10.1 Procedure

The body of the cylinder shall be held in such a manner as to prevent it rotating. The cylinder shall be fitted with a corresponding valve and tightened to 150 % of the maximum torque specified in ISO 13341 for the relevant liner material or as recommended by the manufacturer where ISO 13341 does not apply.

The parameters that shall be monitored and recorded are:

- a) type of valve and plug material;
- b) valving procedure;
- c) applied torque.

8.5.10.2 Criteria

The cylinder neck and threads shall remain within drawing and gauge tolerance.

8.5.11 Environmentally assisted stress rupture test

8.5.11.1 Procedure

This test shall be conducted only on cylinders where glass or aramid fibre has a load-sharing application.

For a design life of up to 20 years, two cylinders shall be hydraulically pressurized to test pressure, p_h , and maintained at this pressure for 1 000 h. For a design life equal to or greater than 20 years, the test shall run for 2 000 h. The test shall be conducted at a minimum temperature of $70\text{ °C} \pm 5\text{ °C}$ and a relative humidity greater than or equal to 95 %. Use of a water spray or suspending the cylinder over water bath meets the requirements of this test.

After this test, the cylinders shall be subjected to the burst test (see 8.5.4).

The parameters that shall be monitored and recorded are:

- a) temperature and relative humidity at least twice a day;
- b) cylinder pressure at least twice a day;
- c) burst pressure.

8.5.11.2 Criteria

The cylinder shall not exhibit any visible deformation or loose fibres (unravelling) and the burst pressure, p_b , shall be equal to or greater than 100 % of the minimum burst level required in the burst test (see 8.5.4) for the relevant fibre.

8.5.12 Drop test

8.5.12.1 General

This test is only applicable to cylinders with test pressure <60 bar.

8.5.12.2 Procedure

Two cylinders shall be filled with water to 50 % capacity and fitted with a plug flush with the end of each cylinder.

Both cylinders shall be dropped twice, in each of the five positions shown in Figure 1, from a height of 1,2 m on to a steel plate of a minimum of 5 mm thickness. The protective plate shall be sufficiently flat so that the difference in level between any two points on the surface is no more than 2 mm.

One cylinder shall be subjected to the burst test in 8.5.4.

The other cylinder shall be subjected to the pressure cycling test in 8.5.5.

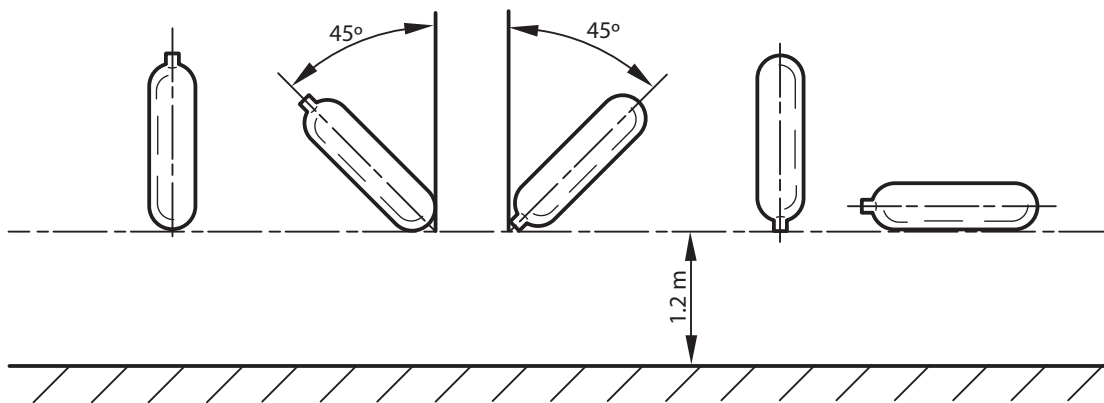

Figure 1 — Drop test

The following parameters that shall be monitored and recorded are:

- a) visual appearance after each drop — record position and dimensions of impact damage;
- b) parameters specified in 8.5.4;
- c) parameters specified in 8.5.5.

8.5.12.3 Criteria

First cylinder: burst pressure, p_b , shall be equal to or greater or equal to 100 % of the minimum burst level required in the burst test (see 8.5.4) for the relevant fibre.

Second cylinder: the cylinder shall satisfy the requirements of the ambient cycle test (see 8.5.5).

8.6 Failure of type approval tests

In the event of failure to meet test requirements, an investigation into the cause of failure and retesting shall be performed in accordance with 9.5.

9 Batch inspection and testing

9.1 Liner

9.1.1 Each batch of liners shall be examined and dimensionally checked to ensure compliance with the design specification. The inspections to be carried out in accordance with the manufacturer's quality assurance procedures are listed in a) to f).

- a) Visual inspection of external and internal surface finish.
- b) Dimensions.
- c) Neck folds. Interior folding in the liner neck area shall be prohibited. Smooth gathering of the material in the neck in which there are no sharp rooted folds shall be allowed.
- d) Minimum wall thickness.
- e) Water capacity.
- f) Thread conformity.

9.1.2 If finished cylinders are subjected to a hydraulic proof pressure test, then 100 % of liners (if they are heat treated) shall be subjected to hardness testing after heat treatment in accordance with either ISO 6506-1 or ISO 6508-1 and shall achieve the limits specified in 7.2.2.

If a finished cylinder is subjected to a hydraulic volumetric expansion test, then 5 % of liners shall be subjected to hardness testing in accordance with either ISO 6506-1 or ISO 6508-1 and shall achieve the limits specified in 7.2.2.

9.1.3 For heat treated liners, one liner from every batch of liners shall be tested to verify that the mechanical properties meet the minimum design requirements in accordance with the relevant standard for the liner material (see Clause 2). For cylinders above 10 l water capacity a representative coupon for heat treatment can be substituted.

9.1.4 For non-heat treated liners, one liner from every batch of liners shall be tested in accordance with the liner burst test (8.5.3) to verify that the mechanical properties meet the minimum design requirements.

9.1.5 A record of the tests performed shall be kept by the cylinder manufacturer. Suitable forms of test certificate are shown in Annex B.

9.1.6 In the event of failure to meet test requirements, an investigation into the cause of failure and re-testing shall be performed in accordance with 9.2.

9.2 Failure of liner batch tests

9.2.1 If any of the test results are not satisfactory, and if the inspector is satisfied that this was due to an error in performing the test, a retest shall be authorized using the same liner or if that is not possible, follow either a) or b).

- a) The test in question shall be repeated on a liner or test ring from the same batch, and if the results are satisfactory the batch shall be accepted.
- b) Where heat treatment has been shown to be inadequate, liners shall be subjected to re-treatment, and re-tested in accordance with 9.1.2 and 9.1.3. If the results are satisfactory, the batch shall be accepted. This re-treatment can be conducted only once.

9.2.2 Where heat treatment furnace records show that artificial ageing has been inadequate, additional time at the ageing temperature shall be given.

9.2.3 If the test results, having allowed for retesting or reheat treatment, are not satisfactory, liners in the batch shall be rendered unserviceable.

9.3 Overwrap materials

9.3.1 Supplier's attestation of the material properties shall serve as verification of compliance. The strength of fibres shall be not less than specified in the documentation listed in 7.2.3.

9.3.2 If attestation is not available, each batch of filament materials shall be subjected to an impregnated strand test in accordance with ISO 3341 for glass fibre, ASTM D7269 for aramid and ISO 10618 for carbon fibre or an appropriate equivalent standard. The strength of fibres shall be not less than specified in the documentation listed in 7.2.3.

9.3.3 Each batch of steel wire shall be subjected to a tensile test in accordance with ISO 6892-1 or identified equivalent standards accepted by the inspector. The strength of the wire shall be not less than specified in the documentation listed in 7.2.3.

9.4 Composite cylinder

9.4.1 The inspector shall certify that the design, manufacture, inspection, and testing were carried out in accordance with this part of ISO 11119. An example form of certificate is shown in Annex B.

9.4.2 Each batch of composite cylinders shall be examined and checked in order to ensure compliance with the design standard. The inspections that shall be carried out in accordance with the manufacturer's quality assurance procedures are:

- a) visual inspection of external and internal surface finish;
- b) dimensions;
- c) markings;
- d) water capacity;
- e) mass;
- f) cleanliness;
- g) fibre tension (where applicable).

9.4.3 The internal and external surfaces of the finished cylinder shall be free from defects and residues from the manufacturing process which would adversely affect the safe working of the cylinders.

NOTE See ISO 9809-1, ISO 9809-2, ISO 9809-3 and ISO 7866 for guidance on possible defects in metallic liners.

9.4.4 Each completed cylinder shall be subjected to either a hydraulic proof test (in accordance with 8.5.1) or a volumetric expansion test (in accordance with 8.5.2) at the design test pressure specified in the documentation in 7.2.4 as specified in the manufacturer's quality assurance procedures.

9.4.5 A pressure cycling test shall be conducted on no less than one finished cylinder per five batches (a maximum of 1 000 pieces produced sequentially). The cylinder to be tested shall be selected at random from the five batches. If the cylinder fails the test all five batches shall not be released until the investigation carried out in accordance with 9.5 is completed.

The cylinder shall be subjected to a hydraulic pressure cycle test to test pressure, p_h , for unspecified gas service or maximum developed pressure at 65 °C, p_{max} , for dedicated gas service. The procedure shall be in accordance with 8.5.5, except that the test can be suspended, as appropriate to the design, either after 12 000 hydraulic cycles to test pressure or 24 000 cycles to maximum developed pressure or after N or N_d cycles where:

$$N = t \times 250 \text{ cycles to test pressure per year of design life or}$$

$$N_d = t \times 500 \text{ cycles to maximum developed pressure per year of design life}$$

where t is the number of years of design life.

Cylinders with a test pressure of 60 bar and above shall withstand N pressurization cycles to test pressure, p_h , (up to a maximum of 12 000 cycles), or N_d pressurization cycles to maximum developed pressure, p_{max} (up to a maximum of 24 000 cycles), without failure by bursting or leakage. Cylinders with a test pressure below 60 bar shall withstand 12 000 pressurization cycles to test pressure, p_h , without failure by bursting or leakage.

9.4.6 One cylinder per batch of finished cylinders shall be subjected to a burst test in accordance with 8.5.4.

NOTE The cylinder subjected to the pressure cycle test (see 9.4.5) can be used for this test.

The burst pressure, p_b , shall be in accordance with the criteria for the cylinder burst test specified in 8.5.4 for the relevant fibre.

9.5 Cylinder failure during type approval or batch testing

9.5.1 In the event of failure to meet test requirements either during a production run (batch test) or when design type approval tests do not give satisfactory results, an investigation into the cause of failure and retesting shall be carried out.

9.5.2 If there is evidence of a fault in carrying out a test, or an error of measurement, if possible a second test shall be performed on the same cylinder. If this is not possible, then a second test shall be performed on a cylinder selected at random from the batch. If the results of this test are satisfactory, the first test shall be ignored.

9.5.3 If the test has been carried out in a satisfactory manner, either:

- a) the cause of failure shall be identified and the procedure detailed in 9.5.4 or 9.5.5 shall be followed; or
- b) the batch shall be rejected and made unserviceable.

9.5.4 If the cause of failure is identified, the defective cylinders can be reclaimed by an approved method or shall be rejected. All cylinders from the batch represented by the failed cylinder shall be tested and the passed and failed cylinders shall be separated into two batches. The failed test shall be repeated with the quantities required in 8.5.4 or 8.5.5 (as applicable) for both batches. For failures found during 100 % batch testing, only the repaired cylinders need to be re-tested. If one or more tests prove even partially unsatisfactory, all the cylinders of the batch(es) covered by the tests shall be rejected.

9.5.5 Alternatively the cause of failure can be investigated and if this is identified the defective cylinders in the batch shall be removed from the batch and the failed test shall be repeated with the quantities required in 8.5.4 or 8.5.5 (as applicable) for the original batch.

9.5.6 If a batch fails the second series of tests, the batch of cylinders shall be scrapped and rendered unserviceable for holding gas under pressure.

10 Cylinder marking

10.1 General

Each finished composite cylinder which satisfies the requirements of this part of ISO 11119 shall be permanently and legibly marked in accordance with ISO 13769 and ISO 7225 or the relevant marking regulations of the countries of use, except that the empty mass shall be the nominal mass.

Stamped markings shall be in a low stress area.

IMPORTANT Attention is drawn to requirements for marking in relevant regulations that might override the requirements given in this part of ISO 11119.

10.2 Additional markings

10.2.1 When applicable, the cylinder shall be permanently and legibly marked using a label which is either attached to the cylinder surface, in the resin or under a glass fibre layer. The applicable information to be included on the label is dependent upon cylinder use, but shall be selected from:

- a) **“WARNING — FILL THIS CYLINDER ONLY WITH << Named Gas(es) >>”** where a cylinder is to be used for dedicated gas service;
- b) **“WARNING — THIS CYLINDER HAS BEEN QUALIFIED WITH A << Named >> PRESSURE RELIEF DEVICE”** where a cylinder is approved with a specific pressure relief device (see 8.5.8);
- c) **“Maximum torque <<manufacturer’s recommended torque>>”**, where fitting torque does not correspond to the values given in ISO 13341 or where the thread is not listed in ISO 13341.

- d) details of components that are permanently attached to the cylinder and form part of the qualified design (neck rings, protective boots, etc.) with instructions that they shall not be removed at periodic inspection.
- e) other additional markings such as re-test dates (in accordance with national legislation), customer names etc.

10.2.2 All labels shall be clearly marked with letters of height not less than 3 mm.

Annex A
(informative)

Example of design approval certificate

Design approval certificate – hoop-wrapped composite cylinders

Issued by *(Relevant authority)* on the basis of applying ISO 11119-1, *Gas cylinders — Refillable composite gas cylinders and tubes — Design, construction and testing — Part 1: Hoop-wrapping fibre reinforced composite gas cylinders and tubes up to 450 l.*

Approval No. Date

Cylinder description *(Family of cylinders which has received type approval)*.....

Manufacturer's drawing No.

Design life Underwater Special torque Pressure relief device

Liner heat treatment Details

Finished cylinder		Liner		Composite material	
Capacity	l	Material		Fibre(s)/wire	
Test pressure	bar	Min. thickness	mm	Fibre(s)/wire tensile strength	MPa
Diameter	mm	Min. yield strength	MPa	Fibre(s)/wire modulus	GPa
Length	mm	Min. tensile strength	MPa	Matrix components	
Thread		Elongation	%	Shear strength	MPa
Autofrettage pressure	bar	Min. burst pressure	bar	Thickness	mm

Compatible gases

Manufacturer or agent *(Name and address of manufacturer or its agent)*

Type of approval mark

Details of the results of the examination of the design for design approval are detailed in Type approval Test Report

All information can be obtained from *(Name and address of the approving body)*

Date Place

Signature

Annex B
(informative)

Specimen test reports

VERIFICATION BODIES REPORT ON:

THE MANUFACTURE OF HOOP-WRAPPED COMPOSITE GAS CYLINDERS TO STANDARD

Approved inspection body _____

Mark of approved inspection body _____

Certificate No. _____

Place _____ Date _____

Cylinders manufactured by _____

Manufacturer's mark _____

Manufactured for _____

Consigned to _____

Quantity _____ Overall size (mm) _____ Outside diameter by _____ Length _____

Serial numbers _____ to _____ inclusive

Standard

Drawing No. _____

Date of hydraulic pressure test _____

Test pressure (bar) _____

Water capacity (litres) _____

Gas _____ Filling pressure (permanent) (bar) _____

Filling ratio (liquefied) (bar) _____

Mass of container (in kg) Minimum _____ Maximum _____ Without valve

Minimum _____ Maximum _____ With valve

NOTE Items in brackets below refer to the clauses of ISO 11119-1:2012.

Each cylinder was made by over-wrapping a seamless liner with resin-impregnated filament or steel wire reinforcement (delete as appropriate).

Liner material designated as _____ was supplied by _____ and the cast analysis was within the required limits.

Each liner was produced by an approved process (4.4.1), heat treated by an appropriate method and checked for hardness. The results of the mechanical tests have been found satisfactory (see 9.1.3).

Overwrap was applied by wrapping under controlled tension.

Filament Glass Carbon Aramid Steel

designated _____

supplied by _____

impregnated with resin designated _____

manufactured by _____

Identified by package number and cured after wrapping to the manufacturer's standard.

Filament strand strength was verified and found satisfactory.

Each cylinder was subjected to an autofrettage pressure of _____ for approximately _____ (if appropriate)

Each cylinder was subjected to a proof pressure test (8.5.1) or hydraulic volumetric expansion test (8.5.2) at the test pressure stated above.

The results of the batch pressure cycle and burst tests were satisfactory.

Each cylinder has been marked as required by ISO 11119-1 (clause 10).

WE HEREBY CERTIFY that each of the above cylinders meets, in full, the requirements of ISO 11119-1.

For and on behalf of the manufacturer _____

For and on behalf of the Approved Inspection Body

Specimen test reports (continued)

1. Mechanical tests on seamless liners

Batch No. Code	Test piece dimensions mm	0,2 % yield strength MPa	Tensile strength MPa	Elongation %
----------------	-----------------------------	-----------------------------	-------------------------	-----------------

For and on behalf of the manufacturer _____

2 Hydraulic volumetric expansion test certificate for composite cylinders

Customer order No. _____

Tested to a pressure and conforming to _____

Manufacturer's No. _____

Container No.	Test date	Cast No.	Total expansion ml	Permanent expansion ml	Perm./Total expansion ratio %	Mass full kg	Mass empty kg	Water capacity l
---------------	-----------	----------	-----------------------	---------------------------	----------------------------------	-----------------	------------------	---------------------

Declared by _____ on behalf of _____ Date _____

(for manufacturer)

Certified by _____ Date _____

(approved inspection body)

Bibliography

- [1] ISO 7438, *Metallic materials — Bend test*
- [2] ISO 10156, *Gases and gas mixtures — Determination of fire potential and oxidizing ability for the selection of cylinder valve outlets*
- [3] ISO 11114-2: *Gas cylinders — Compatibility of cylinder and valve materials with gas contents — Part 2: Non-metallic materials*
- [4] ISO 11117, *Gas cylinders — Valve protection caps and valve guards — Design, construction and tests*
- [5] ISO 11439, *Gas cylinders — High pressure cylinders for the on-board storage of natural gas as a fuel for automotive vehicles*
- [6] ISO 11623, *Transportable gas cylinders — Periodic inspection and testing of composite gas cylinders*
- [7] ISO 14130, *Fibre-reinforced plastic composites — Determination of apparent interlaminar shear strength by short-beam method*
- [8] ASTM D2290, *Standard test method for apparent hoop tensile strength of plastic or reinforced plastic pipe by split disk method*
- [9] ASTM D 2291, *Standard practice for fabrication of ring test specimens for glass–resin composites*
- [10] ASTM D2344, *Standard test method for short-beam strength of polymer matrix composite materials and their laminates*
- [11] EN 3-7, *Portable fire extinguishers — Part 7: Characteristics, performance requirements and test methods*
- [12] EN 144-1, *Respiratory protective devices — Gas cylinder valves — Part 1: Thread connections for insert connector*
- [13] CGA Pamphlet C-6.2, *Guidelines for visual inspection and re-qualification of fiber reinforced high pressure cylinders*. Arlington, VA: Compressed Gas Association
- [14] CGA C14, *Procedures for testing of DOT cylinder pressure relief device systems*. Arlington, VA: Compressed Gas Association
- [15] UNITED NATIONS. *Recommendations on the transport of dangerous goods: Model regulations*, 17th edition, 2 vols. New York, NY: United Nations, 2011. (ST/SG/AC.10/1/Rev.17). Available (viewed 2012-04-25) from: http://www.unece.org/trans/danger/publi/unrec/rev17/17files_e.html

