



DRAFT INTERNATIONAL STANDARD ISO/DIS 11515.2

ISO/TC 58/SC 3

Secretariat: BSI

Voting begins on
2012-01-13

Voting terminates on
2012-03-13

INTERNATIONAL ORGANIZATION FOR STANDARDIZATION • МЕЖДУНАРОДНАЯ ОРГАНИЗАЦИЯ ПО СТАНДАРТИЗАЦИИ • ORGANISATION INTERNATIONALE DE NORMALISATION

Gas cylinders — Refillable composite reinforced tubes of water capacity between 450 L and 3000 L — Design, construction and testing

Bouteilles à gaz — Bouteilles tubulaires en composite renforcé rechargeables d'une capacité de 450 L à 3000 L — Conception, construction et essais

ICS 23.020.30

In accordance with the provisions of Council Resolution 15/1993 this document is circulated in the English language only.

Conformément aux dispositions de la Résolution du Conseil 15/1993, ce document est distribué en version anglaise seulement.

To expedite distribution, this document is circulated as received from the committee secretariat. ISO Central Secretariat work of editing and text composition will be undertaken at publication stage.

Pour accélérer la distribution, le présent document est distribué tel qu'il est parvenu du secrétariat du comité. Le travail de rédaction et de composition de texte sera effectué au Secrétariat central de l'ISO au stade de publication.

THIS DOCUMENT IS A DRAFT CIRCULATED FOR COMMENT AND APPROVAL. IT IS THEREFORE SUBJECT TO CHANGE AND MAY NOT BE REFERRED TO AS AN INTERNATIONAL STANDARD UNTIL PUBLISHED AS SUCH.

IN ADDITION TO THEIR EVALUATION AS BEING ACCEPTABLE FOR INDUSTRIAL, TECHNOLOGICAL, COMMERCIAL AND USER PURPOSES, DRAFT INTERNATIONAL STANDARDS MAY ON OCCASION HAVE TO BE CONSIDERED IN THE LIGHT OF THEIR POTENTIAL TO BECOME STANDARDS TO WHICH REFERENCE MAY BE MADE IN NATIONAL REGULATIONS.

RECIPIENTS OF THIS DRAFT ARE INVITED TO SUBMIT, WITH THEIR COMMENTS, NOTIFICATION OF ANY RELEVANT PATENT RIGHTS OF WHICH THEY ARE AWARE AND TO PROVIDE SUPPORTING DOCUMENTATION.

Copyright notice

This ISO document is a Draft International Standard and is copyright-protected by ISO. Except as permitted under the applicable laws of the user's country, neither this ISO draft nor any extract from it may be reproduced, stored in a retrieval system or transmitted in any form or by any means, electronic, photocopying, recording or otherwise, without prior written permission being secured.

Requests for permission to reproduce should be addressed to either ISO at the address below or ISO's member body in the country of the requester.

ISO copyright office
Case postale 56 • CH-1211 Geneva 20
Tel. + 41 22 749 01 11
Fax + 41 22 749 09 47
E-mail copyright@iso.org
Web www.iso.org

Reproduction may be subject to royalty payments or a licensing agreement.

Violators may be prosecuted.

Contents

	Page
Foreword	v
Introduction.....	vi
1 Scope	1
2 Normative references	1
3 Terms and definitions	3
4 Symbols.....	5
5 Inspection and testing	5
6 Materials	5
6.1 Liner materials	5
6.2 Composite overwrap	6
7 Design and manufacture.....	7
7.1 General	7
7.2 Design submission.....	7
7.3 Manufacturing.....	9
8 Type approval procedure.....	9
8.1 General requirements	9
8.2 Prototype tests	9
8.3 New design.....	10
8.4 Design variants.....	11
8.5 Type Approval test procedures and criteria.....	16
8.5.1 Hydraulic proof pressure test.....	16
8.5.2 Hydraulic volumetric expansion test.....	16
8.5.3 Liner burst test	17
8.5.4 Tube burst test.....	17
8.5.5 Ambient cycle test.....	18
8.5.6 Environmental cycle test	19
8.5.7 Flaw test	20
8.5.8 Blunt impact test	22
8.5.9 Fire resistance test.....	22
8.5.10 Neck strength test	23
8.5.11 Leak test	24
8.5.12 Accelerated stress rupture test	24
8.5.13 Permeability test.....	25
8.5.14 Gas cycle test	25
8.5.15 Coatings test.....	26
8.5.16 Salt Spray Test.....	27
8.5.17 Acid Environment test	27
8.5.18 High velocity impact (Gunfire) test.....	28
8.5.19 Vacuum test	28
8.6 Failure of Type Approval tests.....	29
9 Inspection and testing at time of manufacture.....	29
9.1 Liners for Type 2 and Type 3 Tubes	29
9.2 Liners for Type 4 Tubes	30
9.3 Failure of liner batch tests.....	30
9.4 Overwrap materials	31
9.5 Composite tube	31
9.6 Failure of Batch tests	32

10	Tube marking	32
10.1	General.....	32
10.2	Additional marking	32
Annex A (informative) Examples of design approval certificate		33
Annex B (informative) Specimen test reports		34
Annex C (normative) Ultrasonic inspection		37
C.1	General.....	37
C.2	General requirements.....	37
C.3	Flaw detection of the cylindrical parts	37
C.3.1	Procedure	37
C.3.2	Reference Standard	38
C.3.3	Calibration of equipment	40
C.3.4	Wall thickness measurement	40
C.3.5	Interpretation of results	40
C.3.6	Certification	40
Bibliography		41

D
R
A
F
T
2

Foreword

ISO (the International Organization for Standardization) is a worldwide federation of national standards bodies (ISO member bodies). The work of preparing International Standards is normally carried out through ISO technical committees. Each member body interested in a subject for which a technical committee has been established has the right to be represented on that committee. International organizations, governmental and non-governmental, in liaison with ISO, also take part in the work. ISO collaborates closely with the International Electrotechnical Commission (IEC) on all matters of electrotechnical standardization.

International Standards are drafted in accordance with the rules given in the ISO/IEC Directives, Part 2.

The main task of technical committees is to prepare International Standards. Draft International Standards adopted by the technical committees are circulated to the member bodies for voting. Publication as an International Standard requires approval by at least 75 % of the member bodies casting a vote.

Attention is drawn to the possibility that some of the elements of this document may be the subject of patent rights. ISO shall not be held responsible for identifying any or all such patent rights.

ISO 11515 was prepared by Technical Committee ISO/TC 58, *Gas cylinders*, Subcommittee SC 3, *Cylinder design*.

This is a first edition.

Introduction

The purpose of this International Standard is to provide a specification for the design, manufacture, inspection and testing of a composite tube for worldwide usage. The objective is to balance design and economic efficiency against international acceptance and universal utility.

ISO 11515 aims to eliminate the concern about climate, duplicate inspection and restrictions currently existing because of lack of definitive International Standards. This standard should not be construed as reflecting on the suitability of the practice of any nation or region.

ISO 11515 addresses the general requirements on design, construction and initial inspection and testing of pressure receptacles of the United Nations *Recommendations on the Transport of Dangerous Goods Model Regulations*.

Annexes A and B of ISO 11515 are for information only.

DRAFT

Gas cylinders — Refillable composite reinforced tubes of water capacity between 450 L and 3000 L — Design, construction and testing

1 Scope

This International Standard specifies minimum requirements for the design, construction and performance testing of composite reinforced tubes between 450 l and 3 000 l water capacity, for the storage and conveyance of compressed or liquefied gases with test pressures up to and including 1600 bar with a design life of between 15 and 30 years. The expected service temperatures are between -40°C and $+65^{\circ}\text{C}$.

The tubes in this standard are defined as one of three Types":

Type 2 - a Hoop Wrapped Tube with a load sharing metal liner and composite reinforcement on the cylindrical portion only.

Type 3 - a Fully Wrapped Tube with a load sharing metal liner and composite reinforcement on both the cylindrical portion and the dome ends.

Type 4 - a Fully Wrapped Tube with a non-load sharing liner and composite reinforcement on both the cylindrical portion and the dome ends.

Type 4 tubes manufactured and tested to this standard are not intended to contain toxic, oxidizing or corrosive gases.

This standard is limited to tubes with composite reinforcement of carbon fibre or aramid fibre or glass fibre (or a mixture thereof) in a matrix.

Composite tubes can be used alone or in batteries to equip trailers or skids (ISO modules) or MEGCs for the transportation and distribution of gases. This International Standard does not include consideration of any additional stresses that can occur during service or transport, e.g. torsional / bending stresses, etc. However it is important that the stresses associated with mounting the tube are considered by the assembly manufacturer and the tube manufacturer.

2 Normative references

The following referenced documents are indispensable for the application of this document. For dated references, only the edition cited applies. For undated references, the latest edition of the referenced document (including any amendments) applies.

ISO 306, *Plastics — Thermoplastic materials — Determination of Vicat softening temperature (VST)*

ISO 527-1: *Plastics — Determination of tensile properties — Part 1: General principles*

ISO 527-2: *Plastics — Determination of tensile properties — Part 2: Test conditions for moulding and extrusion plastics*

ISO 3341: *Textile glass – Yarns – Determination of breaking force and breaking elongation*

ISO 4624, *Paints and varnishes — Pull-off test for adhesion*

ISO 9227, *Corrosion tests in artificial atmospheres — Salt spray tests*

ISO 6506-1, *Metallic materials — Brinell hardness test — Part 1: Test method*

ISO 6508-1, *Metallic materials — Rockwell hardness test — Part 1: Test method (scales A,B,C,D,E,F,G,H,K,N,T)*

ISO 6892-1: *Metallic materials — Tensile testing at ambient temperature*

ISO 7225, *Gas cylinders — Precautionary labels*

ISO 7866, *Gas cylinders — Refillable seamless aluminium alloy gas cylinders — Design, construction and testing*

ISO 9809-1, *Gas cylinders — Refillable seamless steel gas cylinders — Design, construction and testing — Part 1. Quenched and tempered steel cylinders with tensile strength less than 1 100 MPa*

ISO 9809-2, *Gas cylinders — Refillable seamless steel gas cylinders — Design, construction and testing — Part 2: Quenched and tempered steel cylinders with tensile strength greater than or equal to 1 100 Mpa*

ISO 9809-3, *Gas Cylinders – Refillable seamless steel gas cylinders – Design, construction and testing – Part 3: Normalized steel cylinders* ISO 10618: *Carbon Fibre – Determination of tensile properties of resin impregnated yarn*

ISO 11114-1, *Transportable gas cylinders — Compatibility of cylinder and valve materials with gas contents — Part 1: Metallic materials*

ISO 11114-2, *Transportable gas cylinders — Compatibility of cylinder and valve materials with gas contents — Part 2: Non-metallic materials*

ISO 11120, *Gas cylinders – Refillable seamless steel tubes for compressed gas transport, of water capacity between 150 l and 3000 l – Design, construction and testing*

ISO 13341, *Transportable gas cylinders — Fitting of valves to gas cylinders*

ISO 13769, *Gas cylinders — Stamp marking*

ASTM D 522-93a, *Standard Test Methods for Mandrel Bend Test of Attached Organic Coatings.*

ASTM D1308, *Standard Test Method for Effect of Household Chemicals on Clear and Pigmented Organic Finishes.*

ASTM D2794, *Standard Test Method for Resistance of Organic Coatings to the Effects of Rapid Deformation (Impact).* ASTM D3170, *Standard Test Method for Chipping Resistance of Coatings.*

ASTM D7269, *Standard Test Methods for Tensile Testing of Aramid Yarns*

ASTM G53-93, *Standard Practice for Operating Light and Water-Exposure Apparatus (Fluorescent UV Condensation Type) for Exposure of Non-metallic Materials.*

3 Terms and definitions

For the purposes of this document, the following terms and definitions apply :

3.1

aramid fibre

continuous filaments of aramid laid up in tow form, used for reinforcement

3.2

autofrettage

pressure application procedure which strains the metal liner past its yield point sufficient to cause permanent plastic deformation, and results in the liner having compressive stresses and the fibres having tensile stresses when at zero internal gauge pressure

3.3

batch

collective term for a set of homogeneous items or material

NOTE The number of items in a batch can vary according to the context in which the term is used.

3.4

batch of load sharing liners

quantity of up to 30 liners of the same nominal diameter, length, thickness and design, made successively from the same material cast (heat) and processed in the same heat treatment equipment (i.e. a continuous furnace process or a single furnace charge) using the same heat treatment parameters

3.5

batch of non-metallic liners

quantity of non-metallic liners of the same nominal diameter, length, thickness and design, made successively and subjected to the same continuous manufacturing process

3.6

batch of non-load sharing metal liners or metal bosses

quantity of non-load sharing metal liners or metal bosses of the same nominal diameter, length, thickness and design, made successively from the same material cast (heat) and processed in the same heat treatment equipment using the same heat treatment parameters

3.7

batch of finished tubes

production quantity of up to 200 finished tubes successively produced (plus finished tubes required for destructive testing), of the same nominal diameter, length, thickness and design

NOTE The batch of finished tubes can contain different batches of liners, fibres and matrix materials.

3.7

burst pressure

highest pressure reached in a tube during a burst test

3.8

carbon fibre

continuous filaments of carbon laid up in tow form, used for reinforcement

3.9

composite overwrap

the combination of fibres and matrix used to reinforce the tube, including any barrier layers that are a permanent part of the design

**3.10
dedicated gas service**
service in which a tube is to be used only with specified gas or gases

**3.11
equivalent fibre**
fibre equivalent to a fibre used in a previously prototype tested tube

**3.12
exterior coating**
layers of material applied to the tube as protection or for cosmetic purposes

NOTE The coating can be transparent or opaque.

**3.13
equivalent liner**
liner that has certified properties and performance so as to be a direct equivalent to a liner used in an approved tube

**3.14
glass fibre**
continuous filaments of glass laid up in tow form, used for reinforcement

**3.15
leak**
an escape of gas at a rate greater than 5×10^{-3} mbar.l/s through a defect rather than permeation.

**3.16
liner**
inner portion of the composite tube, whose purpose is both to contain the gas and transmit the gas pressure to the fibres

**3.17
load sharing liner**
a liner that has a burst pressure greater than or equal to 5 % of the nominal burst pressure of the finished composite tube

**3.18
non-load-sharing liner**
a liner which has a burst pressure less than 5 % of the nominal burst pressure of the finished composite tube

**3.19
matrix**
material that is used to bind and hold the fibres in place

**3.20
minimum design burst pressure:**
the minimum burst pressure achieved during a burst test

**3.21
tube**
transportable pressure receptacle of a water capacity exceeding 450 litres but not more than 3000 litres

**3.22
representative composite tube**
a shorter tube with the same nominal diameter, and manufactured using the same materials and manufacturing technique, and using a representative wrapping pattern (same number of strands and same number of layers) so as to represent an equivalent stress compared to a full scale prototype

3.23**tubing**

hollow cylindrical body of metal or other material, used for conveying or containing liquids or gases

3.24**Type 2 tube**

hoop wrapped tube with a load sharing metal liner and composite reinforcement on the cylindrical portion only

3.25**Type 3 tube**

fully wrapped tube with a load sharing metal liner and composite reinforcement on both cylindrical and dome ends

3.26**Type 4 tube**

fully wrapped tube with a non-load sharing liner and composite reinforcement on both cylindrical and dome ends

3.27**working pressure**

settled pressure of a compressed gas at a reference temperature of 15 °C in a full tube

4 Symbols

Symbols and their designations

p_b	Burst pressure of finished tube	bar
p_h	Test pressure	bar
p_{max}	Maximum developed pressure at 65 °C	bar
p_w	Working pressure	bar

5 Inspection and testing

ISO 11515 is intended to be used under a variety of national regulatory regimes but has been written so that it is suitable for use with the conformity assessment system of the UN Model Regulations for the Transportation of Dangerous Goods. Attention is drawn to requirements in specified relevant national regulations of the country (countries) where the tubes are intended to be used that might override the requirements given in this International Standard. To ensure that the tubes conform to this International Standard, they shall be subject to inspection and testing in accordance with clauses 6, 7, 8 and 9 by an inspection body (hereafter referred to as "the inspector") authorized to do so.

Equipment used for measurement, testing and examination during production shall be maintained and calibrated within a documented quality management system.

6 Materials**6.1 Liner materials**

6.1.1 Load sharing liner materials shall conform in all relevant respects to the appropriate standards,:

- a) seamless steel liners: ISO 9809-1, ISO 9809-2, ISO 9809-3 or ISO 11120 as appropriate;

- b) seamless aluminium alloy liners: ISO 7866;

Relevant sections are those covering materials, thermal treatments, neck design, construction and workmanship, mechanical tests. Design requirements are excluded since these are specified by the manufacturer for the design of the composite tube (see 7.2.2)

6.1.2 The materials used shall be of uniform and consistent quality. The composite tube manufacturer shall verify that each new batch of materials has the specified properties and qualities, and shall maintain records so that the cast of material and the heat treatment batch (where applicable) used for the manufacture of each tube can be identified. A certificate of conformance from the liner material manufacturer is considered acceptable for the purposes of verification.

6.1.3 The liner shall be manufactured from a metal or alloy suitable for the gas to be contained (see ISO 11114-1). If the gas to be contained is corrosive or embrittling and is not included in ISO 11114-1 and ISO 11114-2 then test 8.5.14 shall be conducted.

6.1.4 When a neck ring is provided, it shall be of a material compatible with that of the tube, and shall be securely attached by a method appropriate to the liner material.

6.1.5 Non-load sharing liner materials shall conform in all relevant respects to the appropriate standards, as follows:

- a) The liner (including metal boss) shall be manufactured from a material suitable for the gas to be contained in accordance with ISO 11114-1 and ISO 11114-2. If the gas to be contained is corrosive or embrittling and is not included in ISO 11114-1 and ISO 11114-2 then test 8.5.14 shall be conducted.
- b) Metal bosses attached to a non-metallic liner shall fulfil the performance requirements of this International Standard.
- c) The tensile yield strength and ultimate elongation of plastic liner material shall be determined at – 50 °C in accordance with ISO 527-2. The test results shall demonstrate the ductile properties of the plastic liner material at temperatures of – 50 °C or lower by meeting the values specified by the manufacturer.
- d) Polymeric materials from finished liners shall be tested in accordance with a method described in ISO 306. The softening temperature shall be at least 100 °C.
- e) If the non-metallic liner materials are not listed in ISO 11114-2 the manufacturer must demonstrate compatibility with the intended gas including passing the requirements of Clause 8.5.18 of ISO 11114-2 for the intended gas of use.

6.2 Composite overwrap

6.2.1 The overwrap filament materials shall be carbon fibre or aramid fibre or glass fibre (or any mixture thereof).

6.2.2 The resin matrix shall be a polymer suited to the application, environment and intended life of the product, e.g. epoxy or modified epoxy with amine or anhydride curing agent, vinyl esters and polyesters.

6.2.3 The supplier of the filament material and the resin matrix system component materials shall provide sufficient documentation for the composite tube manufacturer to be able to identify fully the batch of materials used in the manufacture of each tube.

6.2.4 The materials used shall be of uniform and consistent quality. The composite tube manufacturer shall verify that each new batch of materials has the correct properties and is of satisfactory quality, and maintain records from which the batch of materials used for the manufacture of each tube can be identified. A certificate of conformance from the material manufacturer is considered acceptable for the purposes of verification.

6.2.5 Batches of materials shall be identified and documented to the satisfaction of the inspector.

6.2.6 The manufacturer shall ensure there is no adverse reaction between the liner and the reinforcing fibre, e.g. by the application of a suitable protective coating to the liner prior to the wrapping process (if necessary). NOTE Glass fibre reinforced composite tubes can be susceptible to chemical attack and degradation after being in contact with aggressive acids (e.g. battery acid).

7 Design and manufacture

7.1 General

7.1.1 A Type 2 composite tube shall comprise of:

- 1) an internal metal liner with one or two openings along the central axis only, which carries all the longitudinal load and part of the circumferential load;
- 2) the liner, designed to withstand a burst pressure greater than 0,85 of the test pressure of the finished tube.
- 3) a composite overwrap formed by layers of continuous fibres in a matrix along the parallel portions of the tube sidewall;
- 4) an optional exterior coating to provide external protection. When this is an integral part of the design it shall be permanent.

A Type 3 composite tube shall comprise of:

- 1) an internal metal liner with one or two openings along the central axis only, which carries part of the longitudinal and circumferential load;
- 2) a composite overwrap formed by layers of continuous fibres in a matrix;
- 3) an optional exterior coating to provide external protection. When this is an integral part of the design it shall be permanent.

A Type 4 composite tube shall comprise of:

- 1) an internal metal or non-metallic non-load sharing liner with one or two openings along the central axis only;
- 2) metallic boss(es) for thread connections, where these are part of the design;
- 3) a composite overwrap formed by layers of continuous fibres in a matrix;
- 4) an optional exterior coating to provide external protection. When this is an integral part of the design it shall be permanent.

Composite tubes shall be designed to be suitable to contain gas with a settled temperature between $-40\text{ }^{\circ}\text{C}$ to $65\text{ }^{\circ}\text{C}$.

7.2 Design submission

7.2.1 The design submission for each new design of tube shall include a detailed drawing, along with documentation of the design including, manufacturing and inspection particulars as detailed in 7.2.2, 7.2.3, and 7.2.4.

7.2.2 Documentation for the liner and/or metal boss(es) shall include:

- a) Material details, including limits of chemical analysis;
- b) dimensions, minimum thickness, straightness and out of roundness with tolerances;
- c) process and specification of manufacture;
- d) heat-treatment, temperatures, duration and tolerances (where applicable);
- e) inspection procedures (minimum requirements);
- f) material properties (including hardness for Type 2 and Type 3 tubes);
- g) minimum design burst pressure (for Type 2 and Type 3 tube liners);
- h) dimensional details of valve threads.
- i) method of sealing boss to liner for Type 4 tubes.

7.2.3 Documentation for the composite overwrap shall include:

- a) fibre material, specification and mechanical properties requirements;
- b) minimum composite thickness;
- c) resin system - main components and resin bath temperature where applicable;
- d) thermoplastic matrix system – main component materials, specifications and process temperatures
- e) thermosetting matrix – specifications (including resin, curing agent and accelerator), and resin bath temperature where applicable;
- f) overwrap construction including the number of strands used, number of layers, and layer orientation.

7.2.4 Documentation for the composite tube shall include:

- a) water capacity in litres;
- b) dimensions, minimum thickness, straightness and out of roundness with tolerances;
- c) list of intended contents if intended for dedicated gas service;
- d) working pressure p_w which shall not exceed 2/3 test pressure);
- e) composite tube test pressure, p_h ;
- f) maximum developed pressure at 65 °C for specific dedicated gas(es) p_{max} .
- g) minimum design burst pressure
- h) design life in years between 15 and 30 years.
- i) autofrettage pressure and approximate duration (where applicable);

- j) tensioning of the fibre at winding (where applicable);
- k) weight and manufacturing tolerance;
- l) details of components which are permanently attached and form part of the qualified design (e.g. neck rings, protective boots etc).

7.3 Manufacturing

7.3.1 The liner and metal bosses, where incorporated, shall be manufactured in accordance with the manufacturer's design (see 7.2.2).

7.3.2 The composite tube shall be fabricated from a load sharing or non-load sharing liner over-wrapped with resin impregnated continuous fibres. Winding shall be applied under controlled conditions to develop the design composite thickness and as specified in 7.2.3.

Liners can be stripped and re-wound provided that the overwrap has not been cured. The liner shall not be over-wrapped if it has been damaged or scored by the stripping process.

7.3.3 After winding is completed the composite shall be cured (if appropriate) using a controlled temperature profile as specified in 7.2.3. The maximum temperature shall be such that the mechanical properties of the liner material are not adversely affected.

7.3.4 If tubes are subjected to an autofrettage operation, the autofrettage pressure and duration shall be as specified in 7.2.4. The manufacturer shall demonstrate the effectiveness of the autofrettage by appropriate measurement technique(s) acceptable to the inspector.

7.3.5 If tubes are subjected to a pre-stressing or fibre tensioning during winding to actively change the final stresses in the finished tube, the level of stress shall be as specified in 7.2.4 and levels of stress of tensioning shall be recorded or monitored

8 Type approval procedure

8.1 General requirements

The design submission of each new design of composite tube shall be submitted by the manufacturer to the inspector. The type approval tests detailed in 8.2 shall be carried out on each new design or design variant under the supervision of the inspector.

8.2 Prototype tests

8.2.1 A sufficient number of tubes shall be made available to complete the prototype testing or testing of the design variant.

8.2.4 The inspector shall verify that the batch of liners, prior to being wrapped, conforms to the design requirements and are inspected and tested in accordance with 9.1 or 9.2, as appropriate.

8.2.5 The inspector shall verify that the composite material(s), prior to the tubes being wrapped, conform to the design requirements and are tested in accordance with 9.4.

8.2.6 The inspector shall verify that all tubes in the batch produced for new design approval conform to the design submission and are tested in accordance with 9.5.

8.2.7 Except for the cases identified in 8.2.8, the inspector shall supervise the tests shown in Table 2. An "X" in the relevant column of Table 1 shows that the test is required for the appropriate tube category. A "XX" in the relevant column of Table 1 shows that the test is required for particular materials or particular uses as appropriate. The relevant test describes when the test is required.

Table 1 — Prototype Testing

TEST	TYPE 2 TUBES	TYPE 3 TUBES	TYPE 4 TUBES
8.5.1 Hydraulic proof pressure test, or,	X	X	X
8.5.2 Hydraulic volumetric expansion test	X	X	X
8.5.3 Liner burst test	X	X	
8.5.4 Tube burst test	X	X	X
8.5.5 Ambient temperature cycling test	X	X	X
8.5.6 Environmental cycling test	X	X	X
8.5.7 Flaw test		X	X
8.5.8 Blunt impact test	X	X	X
8.5.9 Fire resistance test	X	X	X
8.5.10 Neck strength test			X
8.5.11 Leak test			X
8.5.12 Accelerated stress rupture	XX	XX	XX
8.5.13 Permeability			XX
8.5.14 Gas cycling test			XX
8.5.15 Coatings test	X	X	X
8.5.16 Salt Spray test	XX	XX	XX
8.5.17 Acid environment	XX	XX	XX
8.5.18 High velocity impact (Gunfire) test	XX	X	X
8.5.19 Vacuum test			XX

8.2.8 For variations in design from the new design tube as specified in 8.4, it is only necessary to carry out the tests as prescribed in Tables 1 to 3 as appropriate. A tube approval by a reduced series of tests shall not be used as a basis for a second design variant approval with a reduced set of tests (i.e. multiple changes from an approved design are not permitted) although individual test results can be used as applicable (see 8.4.2).

8.2.9 If the results of the verifications according to 8.2.4, 8.2.5, 8.2.6 and either 8.2.7 or 8.2.8, as applicable, are satisfactory, the inspector shall issue a type approval certificate, a typical example of which is given in annex A.

8.2.10 After completion of the tests the tubes shall be destroyed or made incapable of holding pressure.

8.3 New design

8.3.1 No alteration shall be made to the design or the method of manufacture after approval unless such alteration has received written prior agreement of the inspector.

8.3.2 A new tube design requires full Type Approval testing. A tube shall be considered to be of a new design compared with an existing approved design if the method of manufacture or tube design has changed to a significant extent, e.g.

- a) It is manufactured in a different factory. A relocation of a factory does not require a new cylinder design approval provided all equipment and procedures remain the same as for the original design approval.

- b) It is manufactured by a process that is significantly different from the process used in the design Type Approval. A significant change is regarded as a change that would have a measurable change in the performance of the liner and/or finished tube. The inspector shall determine when a change in process or design or manufacture is significantly different from the original qualified design.
- c) The nominal outside diameter has changed more than 50 % from the qualified design;
- d) The composite overwrap materials are significantly different from the qualified design e.g. different resin system or fibre type;
- e) The test pressure has increased more than 60% from the qualified design.

8.3.3 A tube shall also be considered to be of a new design compared with an existing approved design if the liner method of manufacture or design has changed to a significant extent, e.g.

- a) It is manufactured from a material of different composition or composition limits from that used in the original type tests;
- b) The material properties are outside the original design limits;

8.4 Design variants

8.4.1 For tubes similar to an approved design a reduced Type Approval testing programme is allowed. A tube shall be considered to be a design variant if :

- a) The length of the tube has changed outside the tolerance of the design drawing;
- b) The outside diameter has changed by has changed by 50% or less ;
- c) The autofrettage pressure has changed by more than 5%.
- d) The base profile and/or base thickness of the liner has changed relative to the tube diameter and minimum wall thickness;
- e) There is a change in the design test pressure up to and including 60 %;

Where a tube is to be used and marked for a lower test pressure than that for which design approval has been given, it is not deemed to be of a new design or design variant.

- f) When changes in diameter or pressure are made the structural wall elements must be operating at the same, or lower nominal stress levels as the original design (e.g. if pressure or diameter increase the wall thickness must increase proportionally)
- g) The composite thickness has changed by more than 5% for reasons other than a change in test pressure or diameter.
- h) The minimum wall thickness of the liner has changed by more than 5%;
- i) When matrix materials (i.e. resin, curing agent, accelerator) are chemically equivalent to the original design;
- j) When equivalent overwrapping fibres are used;

Equivalent fibres are manufactured from the same nominal raw materials, using the same process of manufacture and having the same physical structure and the same nominal physical properties, and where the average tensile strength and modulus is within $\pm 5\%$ of the fibre properties in an approved tube design. Carbon fibres made from the same precursor can be equivalent. Aramid, carbon and glass fibres are not equivalent.

Where a new equivalent fibre has been prototype tested for an existing design, then all the manufacturer's existing prototype tested designs are regarded as prototype tested with the new fibre without the need for any additional prototype testing.

- k) When equivalent liner is used;

Equivalent liners are manufactured from the same nominal raw materials, using the same process of manufacture and having the same physical structure and the same nominal physical properties, are within $\pm 5\%$ of the approved cylinder design and fulfil the requirements of the relevant standard.

- l) When the tube thread has changed.

When a tube design has only a different thread compared to an approved design only the torque test, in accordance with 8.5.10, shall be carried out.

8.4.2 A tube approval by a reduced series of tests (a design variant) shall not be used as a basis for a second design variant approval with a reduced set of tests (i.e. multiple changes from an approved design are not permitted). If a test has been conducted on a design variant (A) that falls within the testing requirements for a second variant (B) then the result for (A) can be applied to the new design variant (B) test program. However design variant (A) cannot be used as the reference for determining the testing required for any new design variant.

8.4.3 Where a design variant involves more than one parameter change all the tests required by those parameter changes shall be performed once only.

8.4.4 The inspector shall determine the level of reduced testing if not defined in Table 2, 3 or 4 for the appropriate tube category, but a fully approved design shall always be used as a reference for the new design variant (i.e. new design variants shall not be approved by reference only to a previous design variant).

Table 2 — Type Approval tests for Type 2 Tubes

Test No.	Test	New Design	Design changes										
			Nominal Length		Nominal Diameter		Equiv. liner	Liner Thickness >5%	Test pressure		Composite thick' >5%	Equiv. fibre	Autofrettage
			≤ 100 %	> 100 %	≤ 20 %	> 20 % ≤ 50 %			≤ 20 %	> 20 % ≤ 60 %			
9.1	Liner material test	X					X	X					
9.4	Composite material tests	X										X	
8.5.1/2	Hydraulic pressure test	X	X	X	X	X	X	X	X	X	X	X	X
8.5.3	Liner burst test	X		X	X	X	X	X					
8.5.4	Tube burst test	X	X	X	X	X	X	X	X	X	X	X	X
8.5.5	Ambient cycle test	X	X	X	X	X	X	X	X	X	X	X	X
8.5.6	Environmental cycle	X											
8.5.8	Blunt impact	X		X		X ^e	X	X ^a		X		X	
8.5.9	Fire resistance	X		X ^f		X		X ^a		X			
8.5.12	Stress rupture	X				X					X	X	
8.5.16	Salt Spray Test ^c	X					X						
8.5.17	Acid Environment Test ^d	X						X		X	X		
8.5.18	High Velocity Impact ^b	X				X ^e				X	X		

^a Test to be conducted on tubes for a reduction in liner thickness of 10% or more. ^b For military applications only.

^c Test to be conducted on tubes with steel liners

^d Test to be conducted on tubes with load bearing glass fibre

^e Test to be conducted for reduction in diameter only.

Table 3 — Type Approval tests for Type 3 Tubes

Test No.	Test	New Design	Design changes										
			Nominal Length		Nominal Diameter		Equiv. liner	Liner thickness >5%	Test pressure		Composite thick' or pattern	Equiv.' fibre	Autofrettage
			≤ 100 %	> 100 %	≤ 20 %	> 20 % ≤ 50 %			≤ 20 %	> 20 % ≤ 60%			
9.1	Liner material test	X					X	X					
9.4	Composite material tests	X										X	
8.5.1/2	Hydraulic pressure test	X	X	X	X	X	X	X	X ^a	X	X	X	X
8.5.3	Liner burst test	X		X	X	X	X	X					
8.5.4	Tube burst test	X	X	X	X	X	X	X	X ^a	X	X	X	X
8.5.5	Ambient cycle test	X	X	X	X	X	X	X	X ^a	X	X	X	X
8.5.6	Environmental cycle	X											
8.5.7	Flaw test	X								X			
8.5.8	Blunt impact	X		X		X ^e			X ^a	X		X	
8.5.9	Fire resistance	X		X		X			X ^a	X			
8.5.12	Stress rupture	X				X				X	X	X	
8.5.16	Salt Spray Test ^d	X					X						
8.5.17	Acid Environment Test ^c	X								X	X		
8.5.18	High Velocity Impact	X				X ^e				X	X		

^a Tests to be conducted on tubes for a reduction in liner thickness of 20% or more. ^b
^c Test to be conducted on tubes with load bearing glass fibre
^d Test to be conducted on tubes with steel liners only
^e Test to be conducted for reduction in diameter only.

Table 4 — Type Approval tests for Type 4 Tubes

Test No.	Test	New Design	Design changes										
			Nominal Length		Nominal Diameter		Equiv. liner	Liner thickness >5%	Test pressure		Composite thick' or pattern	Equiv.' fibre	
			≤ 100 %	> 100 %	≤ 20 %	> 20 % ≤ 50 %			≤ 20 %	> 20 % ≤ 60 %			
9.1	Liner material test	X					X	X					
9.4	Composite material tests	X									X	X	
8.5.1/2	Hydraulic pressure test	X	X	X	X	X	X	X	X ^a	X	X	X	
8.5.4	Tube burst test	X	X	X	X	X	X	X	X ^a	X	X	X	
8.5.5	Ambient cycle test	X	X	X	X	X	X	X	X ^a	X	X	X	
8.5.6	Environmental cycle	X											
8.5.7	Flaw test	X								X			
8.5.8	Blunt impact	X		X		X ^c				X		X	
8.5.9	Fire resistance	X		X		X				X			
8.5.10	Neck strength test	X											
8.5.11	Leak test	X											
8.5.12	Stress rupture	X				X				X	X	X	
8.5.13	Permeability	X				X		X		X			
8.5.14	Gas cycling test	X											
8.5.16	Salt Spray Test ^d	X					X						
8.5.17	Acid Environment Test ^b	X						X		X	X		
8.5.18	High Velocity Impact	X				X ^d				X	X		
8.5.19	Vacuum Test	X											

^a Tests to be conducted on tubes for a reduction in liner thickness of 20% or more. ^b Test to be conducted on tubes with load bearing glass fibre
^c Test to be conducted for reduction in diameter only. ^d Test to be conducted on tubes with steel liners

8.5 Type Approval test procedures and criteria

The manufacturer can conduct more than one of the Type Approval tests on a particular tube with the agreement of the inspector.

Each completed tube shall be subjected to either a hydraulic proof test (in accordance with 8.5.1) or a volumetric expansion test (in accordance with 8.5.2) at the design test pressure specified in 7.2.4

8.5.1 Hydraulic proof pressure test

8.5.1.1 Procedure

When carrying out the pressure test, a suitable fluid (e.g. normally water) shall be used as the test medium. This test requires that the pressure in the tube be increased gradually and regularly until the test pressure, p_h , is reached. The test pressure shall be held for at least 2 min with the tube isolated from the pressure source, during which time there shall be no decrease in the recorded pressure or evidence of any leakage. Adequate safety precautions shall be taken during the test.

If leakage occurs in the piping or fittings, the tube shall be re-tested after repairing such leakages.

The limit deviation on attaining test pressure shall be test pressure +3% / -0 or +10 bar whichever is the lower. Pressure gauges with the appropriate accuracy shall be used.

All internal surfaces of tubes shall be dried (to ensure no free water) immediately after testing.

Where tubes are subjected to autofrettage the hydraulic proof pressure test can be part of, or immediately follow, the autofrettage process.

8.5.1.2 Criteria

The tube shall be rejected if there are leaks, failure to hold pressure or visible permanent deformation after the tube is depressurised.

NOTE Cracking of resin is not necessarily a sign of permanent deformation

8.5.2 Hydraulic volumetric expansion test

8.5.2.1 Procedure

When carrying out the pressure test, a suitable fluid (e.g. normally water) shall be used as the test medium. This test requires that the pressure in the tube be increased gradually and regularly until the test pressure, p_h , is reached. The tube test pressure shall be held for at least 30 s with the tube isolated from the pressure source, during which time there shall be no decrease in the recorded pressure or evidence of any leakage. Adequate safety precautions shall be taken during the test.

If leakage occurs in the piping or fittings, the tube shall be re-tested after repairing such leakages.

The limit deviation on attaining test pressure shall be test pressure +3% / -0 or +10 bar whichever is the lower. Pressure gauges with the appropriate accuracy shall be used.

All internal surfaces of tubes shall be dried (to ensure no free water) immediately after testing.

The total volumetric expansion of each tube under the test pressure, p_h , and the permanent volumetric expansion of the tube after the pressure is released shall be recorded. The elastic expansion (i.e. total expansion less permanent expansion) under test pressure shall be established for each tube.

Where tubes are subjected to autofrettage the hydraulic volumetric expansion pressure test may be part of or immediately follow the autofrettage process.

8.5.2.2 Criteria

The tube shall be rejected if either:

- a) there are leaks or failure to hold pressure, or
- b) it shows a permanent expansion (i.e. volumetric expansion after the pressure has been released) in excess of 5 % of the total expansion.

8.5.3 Liner burst test

8.5.3.1 General

This test is required for liners in Type 2 and Type 3 tubes

8.5.3.2 Procedure

One tube liner shall be tested hydraulically to destruction at a rate of no more than 10 bar/s. The test shall be carried out under ambient conditions.

Parameters to monitor and record are :

- a) burst pressure;
- b) the number of pieces;
- c) description of failure;
- d) pressure/time curve .

8.5.3.3 Criteria

For Type 2 tubes the minimum burst pressure shall be equal to or greater than 0,85 of the tube design test pressure, p_h , and shall be not less than the minimum burst pressure, specified in the design submission 7.2.2. Failure shall initiate in the liner side wall and the liner shall remain in one piece.

For Type 3 tubes the minimum burst pressure shall be not less than the minimum burst pressure, specified in the design submission 7.2.2. Failure shall initiate in the liner side wall and the liner shall remain in one piece.

8.5.4 Tube burst test

8.5.4.1 Procedure

Three tubes shall be tested hydraulically to destruction by pressurising at a rate of no more than 10 bar/s. The test shall be carried out under ambient conditions. Prior to the commencement of the test, it shall be ensured that no air is trapped within the system.

NOTE. There have been examples of premature failure by environmentally assisted stress rupture of pressure vessels reinforced with glass fibre so a higher burst ratio is required for these fibres in this standard. Parameters to monitor and record are:

- a) burst pressure;
- b) description of failure;

c) pressure/time curve or pressure/volume curve.

8.5.4.2 Criteria

8.5.4.2.1 Type 2 Tubes

The burst pressure, p_b , for tubes with carbon fibre reinforcement shall be equal to or greater than the minimum design burst pressure and not less than the test pressure, $p_h \times 1,67$ of the composite tube design.

The burst pressure, p_b , tubes with aramid or glass fibre reinforcement, or a mixture of fibres containing aramid or glass as a structural component, shall be equal to or greater than the minimum design burst pressure and shall be not less than the test pressure, $p_h \times 2,00$ of the composite tube design.

Failure shall initiate in the tube side wall and the tube liner shall not fail into more than one piece.

8.5.4.2.2 Type 3 and Type 4 Tubes

The burst pressure, p_b , for tubes with carbon fibre reinforcement shall be equal to or greater than the minimum design burst pressure and shall be not less than the test pressure, $p_h \times 2$, of the composite tube design.

The burst pressure, p_b , tubes with aramid or glass fibre reinforcement, or a mixture of fibres containing aramid or glass as a structural component, shall be equal to or greater than the minimum design burst pressure and shall be not less than the test pressure, $p_h \times 2,43$ of the composite tube design.

8.5.5 Ambient cycle test

NOTE It is recommended that no air is trapped within the system prior to the commencement of the test.

8.5.5.1 General

Where a tube is intended for use only with one or more specific gases the design can be designated for dedicated gas use. The gases permitted in the tube shall be identified clearly on the tube label (see 10.2).

8.5.5.2 Procedure

Two tubes shall be subjected to a hydraulic pressure cycle test to test pressure, p_h , for unspecified gas service or maximum developed pressure at 65 °C, p_{max} , for the dedicated gas which has the greatest developed pressure.

The test shall be carried out using a non-corrosive fluid under ambient conditions, subjecting the tubes to successive reversals at an upper cyclic pressure that is equal to the hydraulic test pressure, p_h , or maximum developed pressure at 65 °C, p_{max} , as appropriate.

The value of the lower cyclic pressure shall not exceed 10 % of the upper cyclic pressure, but shall have an absolute maximum of 30 bar. The frequency of reversals of pressure shall not exceed 0,25 Hz (15 cycles per min). The temperature on the outside surface of the tube shall not exceed 50 °C during the test.

Parameters to monitor and record are :

- a) temperature of the tube;
- b) number of cycles achieving upper cyclic pressure;
- c) minimum and maximum cyclic pressures;

- d) cycle frequency;
- e) test medium used;
- f) mode of failure, if appropriate.

8.5.5.3 Criteria

The tubes shall withstand N pressurization cycles to test pressure, p_h , or N_d pressurization cycles to maximum developed pressure, p_{max} , without failure by burst or leakage, where:

$$N = y \times 250 \text{ cycles per year of design life;}$$

$$N_d = y \times 500 \text{ cycles per year of design life;}$$

y is the number of years of design life.

y shall be a whole number which is not less than 15 years.

The test shall continue to a total of 15 000 or 30 000 cycles as shown in Table 5, or until the tube fails by leakage, whichever is the sooner. In either case the tube shall be deemed to have passed the test. However, if failure during this second part of the test is by bursting, then the tube shall have failed the test.

Table 5 — Criteria for ambient cycle test

	1st part	2nd part
Number of cycles	0 to N	N to $2N$ but $2N$ no more than 15 000
	0 to N_d	N_d to $2N_d$ but $2N_d$ no more than 30 000
Criteria	No leakage/burst = Pass	
	No leakage or burst	Leakage = Pass
	Pass 1st part	Burst = Fail

8.5.6 Environmental cycle test

8.5.6.1 General

When the vacuum test (see 8.5.19) is performed, the vacuum-tested tube shall be used for the environmental cycle test. When the vacuum test is not performed, a warning shall be permanently marked on the cylinder label (see 10.2).

The tests in this section will be performed in an environmental chamber.

8.5.6.2 Procedure

One tube, as-wrapped and without paint or removable protective coating, shall be tested as follows. Alternatively a representative tube can be tested with the same diameter as the prototype tube but with a cylindrical length of at least twice the diameter. Wrapping pattern of the subscale tube shall be representative of the actual tube.

Condition the tube and contained hydraulic pressurizing medium for 48 h at atmospheric pressure, at a temperature between 60 °C and 70 °C and at a relative humidity greater than or equal to 90 %. The intent of this requirement can be met by spraying with a fine spray or mist of water in a chamber held between 60 °C and 70 °C

The hydraulic pressurizing medium external to the tube under test shall commence the cycle testing at ambient temperature. Hydraulically apply 5 000 cycles from a pressure approximately equal to atmospheric pressure to 2/3 of the test pressure, p_h . The tube skin temperature shall be maintained at between 60 °C and 70 °C by regulating the environmental chamber and the cycling frequency. The cycling frequency shall not exceed 10 cycles/min.

Release the pressure and stabilize the tube at 20 °C approximately.

Stabilize the tube and the contained pressurizing medium until the temperature is between – 40 °C and – 50 °C. The hydraulic pressurizing medium external to the tube under test shall commence the cycle testing at ambient temperature. Apply 5 000 cycles from a pressure less than 10% of working pressure to 2/3 of the test pressure, p_h . The tube skin temperature shall be maintained at between – 40 °C and – 50 °C by regulating the environmental chamber and the cycling frequency. The cycling frequency shall not exceed 10 cycles/min. The fluid shall also be selected to ensure that it functions at the temperatures specified in the various cycle tests.

Release the pressure and stabilize the tube at approximately 20 °C.

Type 4 tubes shall be subjected to the leak test (see 8.5.11)

On completion of these tests the tube shall be subjected to the burst test (see 8.5.4).

Parameters to monitor and record:

- a) temperatures during each part;
- b) humidity during 1st part of test;
- c) test medium used;
- d) number of cycles, achieving upper cyclic pressure, at each stage;
- e) minimum and maximum cyclic pressures;
- f) cycle frequency;
- g) parameters specified in 8.5.4.

8.5.6.3 Criteria

Type 4 tubes must pass the leak test (8.5.11)

The burst pressure, p_b , shall be not less than 85% of the minimum design burst pressure.

8.5.7 Flaw test

8.5.7.1 General

This test is required for all Type 3 and 4 tubes.

One tube shall be tested in accordance with the requirements of 8.5.7.2.

A representative tube can be tested with the same diameter as the prototype tube but with a cylindrical length of at least twice the diameter. Wrapping pattern of the subscale tube shall be representative of the actual tube.

8.5.7.2 Procedure

One longitudinal flaw is cut into each tube, in the mid-length of the cylindrical wall of the tube. The flaw shall be made with a cutter 1 to 3 mm thickness to a depth equal to 20% of the nominal composite thickness and to a length between the centres of the cutter equal to five times the composite thickness.

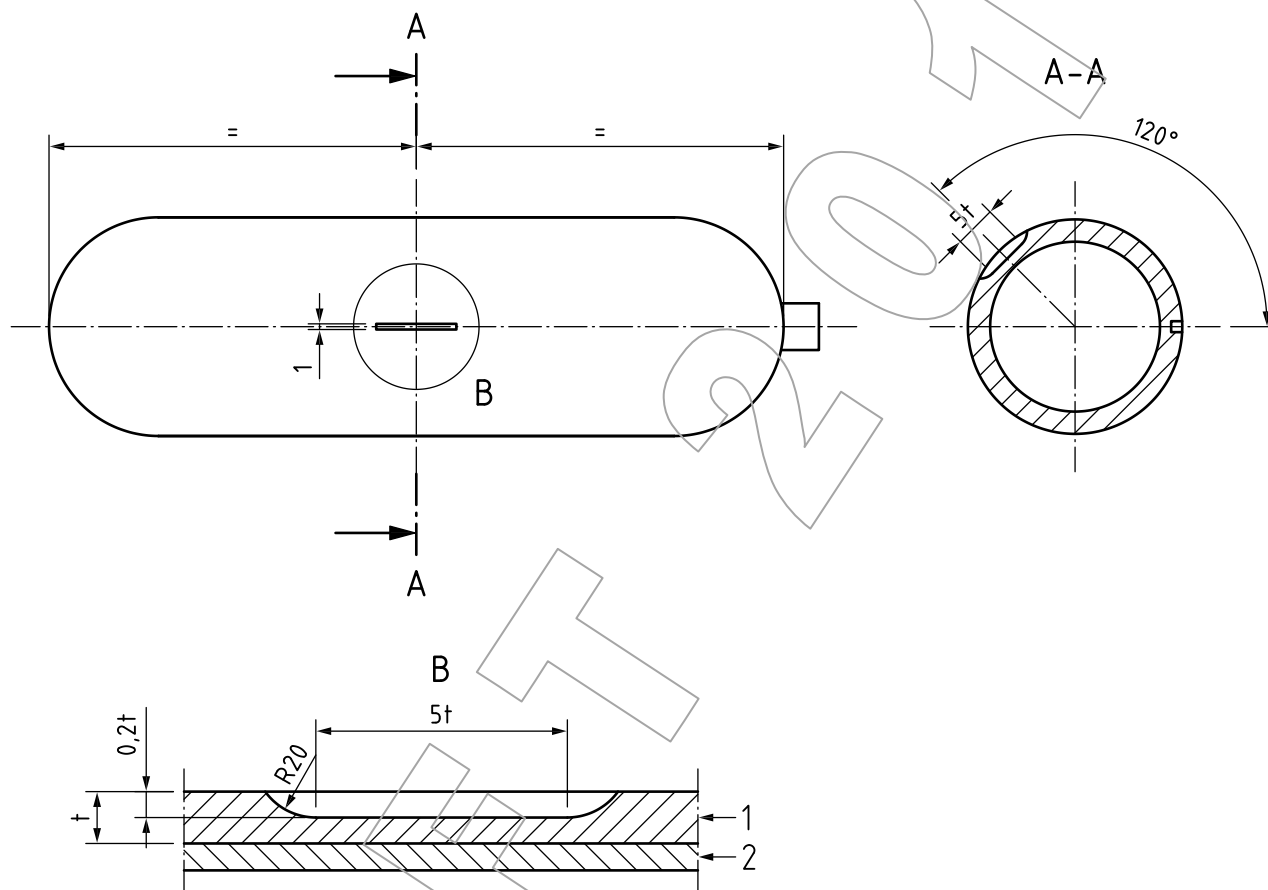

Key

- 1 wrap
- 2 liner

Figure 1 — Flaw test procedure

The tube shall be subjected to the ambient cycle test specified in 8.5.5, but the upper cyclic pressure shall be $2/3$ of the test pressure, p_h , and the test shall be suspended after 3 000 cycles if the tube has not failed.

The flawed tube used for the cycle test is permitted to be used for the burst test in 8.5.4.

Parameters to monitor and record:

- a) dimensions of flaws;
- b) temperature of the tube;
- c) number of cycles achieving upper cyclic pressure;
- d) minimum and maximum cyclic pressures;
- e) cycle frequency;

- f) test medium used;
- g) mode of failure, if appropriate.

At the completion of the test the tube shall be made unserviceable.

8.5.7.3 Criteria

The composite tube shall withstand 3 000 pressure cycles to 2/3 of the test pressure, p_h , without leakage or burst.

8.5.8 Blunt impact test

8.5.8.1 Procedure

For Type 2 tubes, one empty tube shall be subjected to two impacts :

- a) at the tube sidewall midway between the ends;
- b) at the termination of the overwrap near the domes.

For Type 3 and 4 tubes, one empty tube shall be subjected to two impacts in each of the following positions:

- a) at the tube sidewall midway between the ends;
- b) at an angle of 45° to strike the shoulder of the tube (mid arc length at the dome).

The impact can be conducted by dropping a suitable weight or by a pendulum impact.

The tube shall be secured to ensure it does not move during the impact. The impactor shall have a diameter of approximately 10% of the tube diameter and strike the tube with an energy of 1200 joules.

The tube shall then be subjected to the appropriate ambient cycle test as described in 8.5.5.

Parameters to monitor and record are:

- visual appearance after each impact - record position and dimensions of impact damage;
- parameters specified in test 8.5.5.

8.5.8.2 Criteria

The tubes shall withstand 3 000 pressurisation cycles at maximum developed pressure p_{max} without failure by burst or leakage. The test shall continue for a further 12 000 cycles, or until the tube fails by leakage, whichever is the sooner. In either case the tube shall be deemed to have passed the test. However if failure during this second part of the test is by burst, then the tube shall have failed the test.

8.5.9 Fire resistance test

8.5.9.1 General

Precautions shall be taken during fire testing in the event that tube rupture occurs.

8.5.9.2 Procedure

A uniform fire source of 1,65 m length shall be used to provide direct flame impingement on the tube surface across its entire diameter.

Any fuel may be used for the fire source provided it supplies uniform heat sufficient to maintain the specified test temperatures until the tube is vented. The selection of a fuel should take into consideration air pollution concerns. The arrangement of the fire shall be recorded in sufficient detail to ensure the rate of heat input to the tube is reproducible.

Immediately following ignition, the fire shall produce flame impingement on the surface of the tube along the 1,65 m length of the fire source and across the tube diameter.

The fire temperature shall be monitored by at least three thermocouples located along the bottom of the tube and spaced not more than 0,75 m apart. The thermocouples may be inserted into blocks of metal measuring less than 25 mm square to allow stable readings.

Thermocouple temperatures and the tube pressure shall be recorded at intervals of every 30 seconds or less during the test. Within 5 minutes of ignition the temperature at least at one thermocouple shall indicate at least 590 °C. This minimum temperature shall be maintained for the remaining duration of the test.

The tube shall be charged with air or nitrogen or with the gas intended for use to 2/3 of the test pressure, p_t .

The tube shall be placed horizontally with the tube bottom approximately 100 mm above the fire source

- a) If the tube is fitted with a pressure relief device at one end, the fire source shall commence at the opposite end of the tube;
- b) If the tube is fitted with pressure relief devices at both ends, or at more than one location along the length of the tube, the centre of the fire source shall be centred midway between the pressure relief devices that are separated by the greatest horizontal distance;
- c) If the tube is additionally protected using thermal insulation, then two fire tests at service pressure shall be performed, one with the fire centred midway along the tube length, and the other with the fire commencing at one of the ends of a second tube.

8.5.9.3 Criteria

The cylinder shall not burst during a period of two minutes from the start of the fire test. It can vent through the pressure relief device or leak through the cylinder wall or other surfaces.

When multiple tubes are mounted together in an assembly with a fire protection system the manufacturer of the system shall demonstrate that the tubes will vent safely and prevent tube rupture.

8.5.10 Neck strength test

8.5.10.1 General

This test is required for all Type 4 designs. One tube shall be tested.

8.5.10.2 Procedure

The body of the tube shall be held in a manner to prevent it rotating. The tube shall be fitted with a corresponding valve or suitable plug and tightened to 150 % of the maximum torque recommended in ISO 13341 for the relevant liner material and/or boss material, or as recommended by the manufacturer on the design drawing, where this standard does not apply.

Parameters to monitor and record are:

- a) type of valve/plug material;
- b) valving procedure;

c) applied torque.

The valve or plug shall be removed after the first installation and the neck thread and boss inspected. The valve shall then be re-installed as specified above.

The tube shall then be subjected to the Leak Test specified in 8.5.11.

8.5.10.3 Criteria

There shall be no permanent visible damage to any combination of the boss, liner and composite interfaces.

A leakage rate greater than 2 bubble/ min in the bubble leak test or leakage greater than 5×10^{-3} mbar.l/s of gaseous helium (or equivalent) shall constitute a failure of the test.

8.5.11 Leak test

8.5.11.1 General

This test is required for all Type 4 tubes

8.5.11.2 Procedure

Leak testing shall be conducted on the completed tube.

Acceptable methods for leakage testing include bubble testing using dry air or gas or measurement of trace gases using a mass spectrometer, portable gas detector or other suitable technique.

Leak testing of completed tubes shall be performed at $2/3$ times test pressure, p_n .

8.5.11.3 Criteria

Leakage greater than 2 bubble/ min in the bubble leak test or leakage greater than 5×10^{-3} mbar.l/s of gaseous helium (or equivalent) shall constitute a failure of the test.

8.5.12 Accelerated stress rupture test

8.5.12.1 General

This test shall be conducted only on cylinders where glass or aramid fibre has a load sharing application.

Alternatively a representative tube can be tested with the same diameter as the prototype tube but with a cylindrical length of at least twice the diameter. Wrapping pattern of the subscale tube shall be representative of the actual tube

8.5.12.2 Procedure

One tube, as-wrapped and without paint or removable protective coating, shall be tested

For a design life of up to 20 years, one tube shall be hydraulically pressurized to test pressure at 85°C, and shall be maintained at this pressure and at a temperature of 85 °C for 1 000 h.

For a design life equal to or greater than 20 years, one tube shall be hydraulically pressurized to test pressure at 85°C, and shall be maintained at this pressure and at a temperature of 85 °C for 2 000 h.

The tube shall be then be subjected to the burst test (8.5.4).

Parameters to monitor and record are:

- a) temperature at least twice a day;
- b) tube pressure at least twice a day;
- c) burst pressure.

8.5.12.3 Criteria

The tube must not rupture during the 1000 h or 2000 h hold at 85 °C.
The burst pressure shall exceed 85 % of the minimum design burst pressure.

8.5.13 Permeability test

8.5.13.1 General

This test is required for all Type 4 tubes with non-metallic liners. A representative tube can be tested with the same diameter as the prototype tube but with a cylindrical length of at least twice the diameter. Wrapping pattern of the subscale tube shall be representative of the actual tube.

8.5.13.2 Procedure

One finished tube shall be filled with the test gas to working pressure, placed in an enclosed sealed chamber at ambient temperature for 500 h.

Parameters to monitor and record:

- a) test gas used;
- b) permeation rate

8.5.13.3 Criteria

The permeation rate shall be less than the equivalent of 2 ml of hydrogen gas per hour per litre water capacity

8.5.14 Gas cycle test

8.5.14.1 General

This test is required for all Type 4 tubes. A representative tube can be tested with the same diameter as the prototype tube but with a cylindrical length of at least twice the diameter. Wrapping pattern of the subscale tube shall be representative of the actual tube

For other designs (i.e. Type 2 and 3) used in embrittling or corrosive gas service where the material is not explicitly approved in other recognized standards for service this test shall be performed to as part of the Type Approval

Special consideration shall be given to safety when conducting this test. Prior to conducting this test, tubes of this design shall have successfully passed the test requirements of the leak test (8.5.11), the burst test (8.5.4), and the ambient cycle test (8.5.5).

8.5.14.2 Procedure

For dedicated gas service one tube shall be tested with gas to be used in service and subjected to 1000 cycles to maximum developed pressure at 65 °C, p_{max} .

For any compatible gas service, then the tube shall be pneumatically tested with air, natural gas, hydrogen or nitrogen and subjected to 1000 cycles to test pressure.

The value of the lower cyclic pressure shall not exceed 10 % of the upper cyclic pressure, but shall have an absolute maximum of 30 bar. The test shall be suspended if the temperature of the contained gas either exceeds 65 °C or drops below -40 °C during the test and can be resumed once the gas temperature is within the range of -40 °C and 65 °C.

After testing the tube is subjected to the leak test (8.5.11) and must meet the requirements of this test.

The tube shall then be sectioned and the liner and liner/end boss interface inspected for evidence of any deterioration, such as fatigue cracking or electrostatic discharge

Parameters to monitor and record are:

- a) the external surface temperature of the tube boss shall be measured ;
- b) number of cycles achieving upper cyclic pressure;
- c) minimum and maximum cyclic pressures;
- d) cycle frequency;
- e) test medium used;
- f) mode of failure, if appropriate;
- g) results of the leak test
- h) results of visual inspection.

8.5.14.3 Criteria

The tube must not leak or fail during the 1000 cycles.

The tube must pass the leak test (8.5.11) after cycling.

The tube must show no evidence of any deterioration, such as fatigue cracking or electrostatic discharge

8.5.15 Coatings test

Coatings shall be evaluated by: (or using equivalent standards acceptable to the Competent Authority):

- a) adhesion testing, in accordance with ISO 4624, using method A or B as applicable. The coating shall exhibit an adhesion rating of either 4A or 4B, as applicable;
- b) flexibility, in accordance with ASTM D522, using test method B with a 12,7 mm (0,5 in) mandrel at the specified thickness at - 20 °C. Samples for the flexibility test shall be prepared in accordance with ASTM D522-93. There shall be no visually apparent cracks;
- c) impact resistance, in accordance with ASTM D2794. The coating at room temperature shall pass a forward impact test of 18 J (13,3 ft lbs);
- d) chemical resistance, in accordance with ASTM D1308 except that the tests shall be conducted using the open spot test method and 100 h exposure to a 30% sulphuric acid solution (battery acid with a specific gravity of 1,219) and 24 h exposure to a polyalkalene glycol (e.g. brake fluid). There shall be no evidence of lifting, blistering or softening of the coating. The adhesion shall meet a rating of 3 when tested in accordance with ISO 4624;
- e) minimum 1 000 h exposure, in accordance with ASTM G154. There shall be no evidence of blistering and adhesion shall meet a rating of 3 when tested in accordance with ISO 4624. The maximum gloss loss allowed is 20 %;

- f) minimum 500 h exposure in accordance with ISO 9227. Undercutting shall not exceed 2 mm at the scribe mark, there shall be no evidence of blistering and adhesion shall meet a rating of 3 when tested in accordance with ISO 4624;
- g) resistance to chipping at room temperature, in accordance with ASTM D3170. The coating shall have a rating of 7A or better, and there shall be no exposure of the substrate.

8.5.16 Salt Spray Test

8.5.16.1 General

This test is required for composite tubes with steel liners and steel bosses, where these have been designed and constructed for use on road trailers.

The testing shall be performed in accordance with the requirements of ISO 9227.

8.5.16.2 Procedure

For tubes with steel liners the test ring shall be cut from one of the prototype tubes or tubes used as the representative production batch. This shall use the same material/composite wrap combination.

Sample test ring shall have a length of at least 300 mm.

The test ring must be produced by the same method and have the same liner / composite fibre and resin.

Each test ring shall have all exposed fibres around the cut edges sealed and protected by the same resin used in the manufacture of the prototype tubes

Steel bosses shall be tested separately in the final condition intended for service.

The test method shall be as described in 8 to 12 of ISO 9227 using the Neutral Salt Spray (NSS) (described in Table 2 of this document) and with an exposure time of at least 240 Hrs.

After testing has been completed the composite material shall be removed from the liner using a method which does not damage or change the surface of the liner's external surface.

The liner's external surface and that of the composite in contact with liner shall then be examined for signs of corrosion.

8.5.16.3 Criteria

The sample surface must not show pitting greater than 10% of the liner wall thickness. Minor surface rust bloom is acceptable.

8.5.17 Acid Environment test

8.5.17.1 General

This test is required for all composite tubes using either all glass fibre reinforcement or glass fibre to provide some of the load sharing in a hybrid design. A representative tube can be tested with the same diameter as the prototype tube but with a cylindrical length of at least twice the diameter. Wrapping pattern of the subscale tube shall be representative of the actual tube

8.5.17.2 Procedure

One finished tube shall be hydraulically pressurized to 130% of working pressure and a 150 mm diameter area on the tube surface exposed for 100 h to a 30 % sulphuric acid solution (battery acid with a specific gravity of 1,219).

The tube shall then be subjected to the burst test specified in 8.5.4.

8.5.17.3 Criteria

The burst pressure, p_b , shall be not less than 85 % of the minimum design burst pressure.

8.5.18 High velocity impact (Gunfire) test

8.5.18.1 General

This test is mandatory for Type 3 and Type 4 composite tubes. It is mandatory for Type 2 composite tubes that are for military applications, and is optional for other uses.

8.5.18.2 Procedure

One tube shall be filled to the working pressure ($p_h \times 2/3$) with air or nitrogen or the gas to be contained.

The point of impact of the projectile is in the tube side wall and such that the path of the bullet would exit through the tube side wall.

Tubes shall be impacted by a 7,62 mm (30calibre) armour piercing projectile (of length between 37 mm and 51 mm) with a nominal speed of about 850 m/s. The bullet is fired from a distance of not more than 45 m. The tubes must be safely vented before removing from the test.

Parameters to monitor and record are:

- a. type of projectile;
- b. initial pressure;
- c. description of failure;

8.5.18.3 Criteria

The tube shall remain in one piece. If the tube is not penetrated by the projectile then the tube shall have passed the test.

8.5.19 Vacuum test

8.5.19.1 General

When this test is carried out, one tube shall be subjected to a vacuum test prior to the environmental cycle test (see 8.5.6). When this test is not carried out a warning shall be permanently marked on the cylinder label (see 10.2).

8.5.19.2 Procedure

The cylinder shall be subjected to a series of cycles from atmospheric pressure to a vacuum.

The contents (inert gas or air) shall be reduced from atmospheric pressure to a pressure of 0,2 bar absolute at ambient temperature. The vacuum shall be maintained at this level for at least 1 min.

The pressure in the cylinder shall be returned to atmospheric pressure. The total number of cycles shall be 50.

The parameters that shall be monitored and recorded are:

- a) number of cycles achieving lower cyclic pressure;
- b) minimum and maximum cyclic pressures;
- c) cycle frequency;
- d) results of visual inspection.

8.5.19.3 Criteria

After cycling, the interior of the liner shall be inspected for damage. Any evidence of disbonding, folding or other damage shall be noted. If the cylinder then passes the environmental cycle test (see 8.5.6) it shall also be deemed to have passed the vacuum test.

8.6 Failure of Type Approval tests

In the event of failure to meet test requirements, an investigation into the cause of failure and re-testing shall be carried out in accordance with 9.6.

9 Inspection and testing at time of manufacture

9.1 Liners for Type 2 and Type 3 Tubes

9.1.1. Metal tubing used to manufacture Type 2 and Type 3 liners shall be ultrasonically examined in accordance with Annex C.

Additionally all steel liners used to manufacture Type 2 and Type 3 composite tubes shall be ultrasonically examined after completion of all heat treatment in accordance with Annex C.

9.1.2 Every liner shall be inspected for:

- a) surface finish for defects by visual inspection;
- b) dimensions: diameter and length, out of roundness and straightness;
- c) neck folds: Interior folding in the liner neck area shall be prohibited. Smooth gathering of the material in the neck in which there are no sharp rooted folds shall be acceptable.
- d) minimum wall thickness;
- e) weight;
- f) thread conformity.

9.1.3 If finished Type 2 or 3 tubes are subjected to proof test then 100% of liners shall be subjected to hardness test, if they are heat treated, after heat treatment in accordance with ISO 6506-1 or ISO 6508-1 and shall achieve the limits specified in 7.2.2.

If finished tube is subjected to volumetric expansion pressure test then 5% of liners shall be subjected to hardness test after heat treatment in accordance with ISO 6506-1 or ISO 6508-1, and shall achieve the limits specified in 7.2.2.

9.1.4 From every batch, one liner or a representative coupon taken from the supplied tubing subjected to the same heat treatment, shall be tested to determine that the mechanical properties meet the minimum design requirements and according to the relevant standard for the liner material (see clause 2).

9.1.5 A record of the tests carried out shall be kept by the tube manufacturer. Suitable forms of test certificate are shown in annex B.

9.1.6 In the event of failure to meet test requirements, an investigation into the cause of failure and re-testing shall be carried out in accordance with 9.6.

9.2 Liners for Type 4 Tubes

9.2.1 Each liner shall be examined and dimensionally checked to ensure compliance with the design specifications. The following inspections shall be carried out in accordance with the manufacturer's quality assurance procedures:

- a) visual inspection of external and internal surface finish;
- b) dimensions; diameter and length,
- c) thread conformity

9.2.2 Each batch of non-load-sharing metal liners and metallic bosses shall be tested to determine that the required properties specified in 7.2.2 have been achieved. The mechanical properties shall be tested in accordance with ISO 6892-1. Manufacturer's certification (mechanical properties, chemical analysis) shall demonstrate compliance.

9.2.3 Two representative coupons from every batch of non-metallic material shall be tested in accordance with ISO 527-1 and ISO 527-2 to determine that the required properties have been achieved.

Acceptance of non-metallic liners shall take into account:

- a) the properties of the material (raw material as granulate etc.) shall be within the tolerances set by the material manufacturer for melt flow index, density and either glass transition temperature or Vicat softening temperature.;
- b) the process parameters during liner manufacturing shall be within the tolerances agreed during Type Approval of the process;
- c) the material properties of the liner shall be within the tolerances required by the design requirements laid down in 7.2.2.

Manufacturer's certification (mechanical properties, melt flow index, density, glass transition temperature) shall demonstrate compliance.

9.2.4 The liners shall be checked for homogeneity by means of a non-destructive test, specified by the manufacturer, to ensure that the material(s) have been processed correctly.

After heat treatment 5 % of the liners or liner bosses shall be checked for hardness in accordance with either ISO 6506-1 or ISO 6508-1 and shall achieve the limits specified in 7.2.2.

If no heat treat is performed, it is sufficient to check the raw material or have a certificate of conformance to heat treat requirements.

9.2.5 A record of the tests carried out shall be kept at the premises of the tube manufacturer. Suitable forms of test certificates are shown in annex B.

9.3 Failure of liner batch tests

9.3.1 If any of the test results are not satisfactory, and if the inspector is satisfied that this was due to an error carrying out the test, a re-test can be authorised using the same liner otherwise, at the discretion of the manufacturer, either:

- a) the test in question shall be repeated on two specimens, one from the same liner or test ring as for the first test and another one from a liner or test ring from the same batch, and if both results are satisfactory the batch shall be accepted; or
- b) the batch can be re-heat treated (if appropriate) and re-tested in accordance with 9.1.2 and 9.1.3. If the results are satisfactory the batch shall be accepted.

9.3.2 Where heat treatment has been shown to be inadequate, liners can be subjected to re-treatment, once only.

9.3.3 Where heat treatment furnace records show artificial ageing has been inadequate, additional time at the ageing temperature shall be given.

9.3.4 If the test results, having allowed for re-testing or re-heat treatment, are not satisfactory, liners in the batch shall be rendered unserviceable.

9.4 Overwrap materials

9.4.1 The inspector shall certify that the design, manufacture, inspection and testing were carried out in accordance with this standard. An example form of certificate is shown in annex B.

9.4.2 Supplier's certification of the material properties shall serve as verification of compliance. The strength of fibres shall be not less than specified in the documentation listed in 7.2.3.

9.4.3 If certification is not available each batch of filament materials shall be subjected to an impregnated strand test in accordance with ISO 3341 for glass fibre, ASTM D7269 for aramid and ISO 10618 for carbon fibre, or appropriate equivalent standards. The strength of fibres shall be not less than specified in the documentation listed in 7.2.3.

9.4.4 Prototype matrix materials shall be tested on a sample coupon representative of the composite overwrap in accordance with ISO 14130 or an equivalent standard acceptable to the Competent Authority. These tests shall be repeated when matrix materials (i.e. resin, curing agent, accelerator) are changed to be different but are chemically equivalent to the original design.

9.5 Composite tube

9.5.1 The inspector shall certify that the design, manufacture, inspection and testing were carried out in accordance with this standard. An example form of certificate is shown in annex B.

9.5.2 Each batch of composite tubes shall be examined and checked to ensure conformance to the design standard. Inspections shall be carried out in accordance with the manufacturer's quality assurance procedures:

- a) visual inspection of external and internal surface finish;
- b) dimensions;
- c) markings;
- d) water capacity;
- e) weight within the tolerance of the approved design;
- f) cleanliness.

9.5.3 The internal and external surfaces of the finished tube shall be free from defects and residues from the manufacturing process (e.g. swarf, resin), which would adversely affect the safe working of the tubes. See ISO 11120 and ISO 7866 for guidance on possible defects in metallic liners.

9.5.4 Each completed tube shall be subjected to a hydraulic proof test (in accordance with 8.5.1) or a volumetric expansion test (in accordance with 8.5.2) at the design test pressure specified in 7.2.4.

9.5.5 All tubes incorporating non-metallic liners or bonded bosses shall be tested for leakage in accordance with 8.5.11.

Leak testing shall be conducted on the completed tube and shall be performed at 2/3 of the test pressure, p_H .

9.5.6 One tube for each 6 months of production shall be subjected to an ambient cycle test in accordance with 8.5.5.

9.5.7 One tube for each 6 months of production shall be subjected to a burst test in accordance with 8.5.4.

9.6 Failure of Batch tests

9.6.1 In the event of failure to meet test requirements during Batch tests an investigation into the cause of failure and re-testing shall be carried out.

9.6.2 If there is evidence of a fault in carrying out a test, or an error of measurement a second test shall be performed on the same tube, if possible. If this is not possible then a second test shall be performed on a tube selected at random from the batch. If the results of this test are satisfactory, the first test shall be ignored.

10 Tube marking

10.1 General

Each finished composite tube which satisfies the requirement of this International Standard shall be permanently and legibly marked in accordance with ISO 13769 and ISO 7225 or the relevant marking regulations of the countries of use except that the empty weight shall be the nominal weight.

NOTE Attention is drawn to requirements for marking in relevant regulations that might override the requirements given in this International standard.

10.2 Additional marking

- i) **10.2.1** The following information, where applicable, shall be permanently and legibly marked on the tube with a permanent, durable label on the surface or by a label embedded in the resin or under a glass fibre layer. **"WARNING - THIS TUBE MUST BE FILLED ONLY WITH <<Named Gas(es)>>"** where a tube is to be used for dedicated gas service
- ii) **"WARNING - THIS TUBE MUST BE USED ONLY WITH A <<Manufacturer Specified>> PRESSURE RELIEF DEVICE"** where a tube is approved with a specific pressure relief device (see 8.5.10)
- iii) **"Maximum torque <<(manufacturer's recommended torque)>>"** where fitting torque does not correspond to the values given in ISO 13341
- iv) **"WARNING – THIS TUBE MUST NOT BE USED IN VACUUM SERVICE"** when the vacuum test was not successfully completed (see 8.5.19)

10.2.2 Additional markings (e.g. re-test dates in accordance with national legislation, customer names etc.), can be contained on the main label or applied as a secondary label securely affixed to the tube side wall.

10.2.3 All labels shall be clearly marked with letters of not less than 6 mm high.

Annex A (informative) Examples of design approval certificate

Design approval certificate – composite tubes with load bearing metal liners

Issued by.....(*Relevant authority*)..... on the basis of applying ISO 11515- Gas Cylinders - Refillable composite reinforced tubes for compressed gas transport, of water capacity between 450 l and 3 000 l - Design construction and testing.

Approval No.....
Date.....

Tube description.....(*Family of tubes which has received type approval*).....

Manufacturer's Drawing No.....

Design life..... Underwater..... Special torque..... Pressure relief device.....

Liner heat treatment..... Details.....

Finished tube		Liner		Composite material	
Capacity	litres	Material		Fibre(s)	
Test pressure	bar	Min. thickness	mm	Fibre(s) tensile strength	MPa
Diameter	mm	Min. yield strength	MPa	Fibre(s) modulus	GPa
Length	mm	Min. tensile strength	MPa	Matrix components	
Thread		Elongation	%	Shear strength	MPa
Autofrettage pressure	bar	Min. burst pressure	bar	Thickness	mm

Compatible gases:.....

Manufacturer or agent..... (*Name and address of manufacturer or its agent*).....

Type of approval mark.....

Details of the results of the examination of the design for design approval are detailed in Type Approval Test Report.....

All information can be obtained from.....(*Name and address of the approving body*).....

Date.....

Place.....

Signature.....

Annex B
(informative)
Specimen test reports

VERIFICATION BODIES REPORT ON:

THE MANUFACTURE OF COMPOSITE GAS TUBES

Approved Inspection Body _____

Approved Inspection Body's Mark _____

Certificate No. _____

Place _____ Date _____

Tubes manufactured by _____

Manufacturer's mark _____

Manufactured for _____

Consigned to _____

Quantity _____ Overall size (mm) _____ outside diameter by _____ long

Serial numbers _____ to _____ inclusive

Standard

Drawing No _____

Date of hydraulic pressure test _____

Test pressure (bar) _____

Water capacity (litres) _____

Gas _____ Filling pressure (Permanent) (bar) _____

Filling ratio (Liquefied) (bar) _____

Mass of container (in kg) Minimum _____ Maximum _____ Without valve

Minimum _____ Maximum _____ With Valve

Each liner was produced by an approved process in accordance with 6.1 heat treated by an appropriate method and checked for hardness. The results of the mechanical tests have been found satisfactory (see 9.1)

Overwrap was applied by winding under controlled tension.

Filament	Glass	Carbon	Aramid
designated	_____		
supplied by	_____		
Impregnated with resin	_____		
designated	_____		
manufactured by	_____		

Identified by package number and cured after wrapping to the manufacturer's standard. Filaments strand strength and reinforcement were verified and found satisfactory.

Each tube was subjected to an autofrettage pressure of _____ bar for approximately _____ (if appropriate)

Each tube was subjected to a hydraulic proof pressure test (see 8.5.1) or volumetric expansion test (see 8.5.2) at the test pressure stated above.

Each tube has been marked as required by the Standard (see clause 10).

WE HEREBY CERTIFY that each of the above tubes meets in full the requirements of the standard.

For and on behalf of the manufacturer _____

For and on behalf of the Approved Inspection Body _____

DRAFT

Specimen test reports (continued)

1. Mechanical tests on liners

Batch No Code	Test piece dimensions mm	0,2 % yield strength N/mm ²	Tensile strength N/mm ²	Elongation %
---------------	--------------------------	--	------------------------------------	--------------

For and on behalf of the Manufacturer _____

2. Hydraulic volumetric expansion test certificate for composite tubes

Customer Order No _____ Tested to a pressure of _____

and conforming to

Manufacturer's No _____

Container No	Cast No	Total expansion ml	Permanent expansion	Perm/Total expansion ratio %	Mass full kg	Mass empty kg	Water capacity litres	Test date
--------------	---------	--------------------	---------------------	------------------------------	--------------	---------------	-----------------------	-----------

Certified by _____ on behalf of _____ Date _____
(for Manufacturer)

Certified by _____ Date _____
(Approved Inspection Body)

Annex C (normative) **Ultrasonic inspection**

C.1 General

This annex is based on techniques used by cylinder manufacturers. Other techniques of ultrasonic inspection can be used, provided these have been demonstrated to be suitable for the manufacturing method.

C.2 General requirements

The ultrasonic testing equipment shall be capable of at least detecting the reference standard as described in **C.3.2**. It shall be serviced regularly in accordance with the manufacturer's operating instructions to ensure that its accuracy is maintained. Inspection records and approval certificates for the equipment shall be maintained.

The operation of the test equipment shall be by trained personnel and supervised by qualified and experienced personnel certified to level 2 of ISO 9712:1992.

The outer and inner surfaces of any tube which is to be tested ultrasonically shall be in a condition suitable for an accurate and reproducible test.

For flaw detection the pulse echo system shall be used. For thickness measurement either the resonance method or the pulse echo system shall be used. Either contact or immersion techniques of testing shall be used.

A coupling method which ensures adequate transmission of ultrasonic energy between the testing probe and the tube shall be used.

C.3 Flaw detection of the cylindrical parts

C.3.1 Procedure

The tubes to be inspected and the search unit shall have a rotating motion and translation relative to one another such that a helical scan of the tube will be described. The velocity of rotation and translation shall be constant within $\pm 10\%$. The pitch of the helix shall be less than the width covered by the probe (at least a 10% overlap shall be guaranteed) and be related to the effective beam width such as to ensure 100% coverage at the velocity of rotation and translation used during the calibration procedure.

An alternative scanning method may be used for transverse defect detection, in which the scanning or relative movement of the probes and the work piece is longitudinal, the sweeping motion being such as to ensure a 100% surface coverage with about 10% overlap of the sweeps.

The tube wall shall be tested for longitudinal defects with the ultrasonic energy transmitted in both circumferential directions and for transverse defects in both longitudinal directions.

In this case or when optional testing is carried out on the transition areas between the wall and neck and/or wall and base, this can be conducted manually if not carried out automatically.

The effectiveness of the equipment shall be periodically checked by passing a reference standard through the test procedure. This check shall be carried out at least at the beginning and end of each shift. If during this

check the presence of the appropriate reference notch is not detected then all tubes tested subsequent to the last acceptance check shall be retested after the equipment has been reset.

C.3.2 Reference Standard

A reference standard of convenient length shall be prepared from a tube of similar diameter and wall thickness range, and from material with the same acoustic characteristics and surface finish as the tube to be inspected. The reference standard shall be free from discontinuities which can interfere with the detection of the reference notches.

Reference notches, both longitudinal and transverse, shall be machined on the outer and inner surface of the standard. The notches shall be separated such that each notch can be clearly identified.

Dimensions and shape of notches are of crucial importance for the adjustment of the equipment (see Figures C.1 and C.2).

- a) The length of the notches (E) shall be no greater than 50 mm;
- b) The width (W) shall be no greater than twice the nominal depth (T). However, where this condition cannot be met a maximum width of 1,0 mm is acceptable;
- c) The depth of the notches (T) shall be $5\% \pm 0,75\%$ of the nominal thickness (S) with a minimum of 0,2 mm and a maximum of 1,0 mm, over the full length of the notch. Runouts at each end are permissible;
- d) The notch shall be sharp edged at its intersection with the surface of the tube wall. The cross section of the notch shall be rectangular except where spark erosion machining methods are used; then it is acknowledged that the bottom of the notch will be rounded;
- e) The shape and dimensions of the notch shall be demonstrated by an appropriate method.

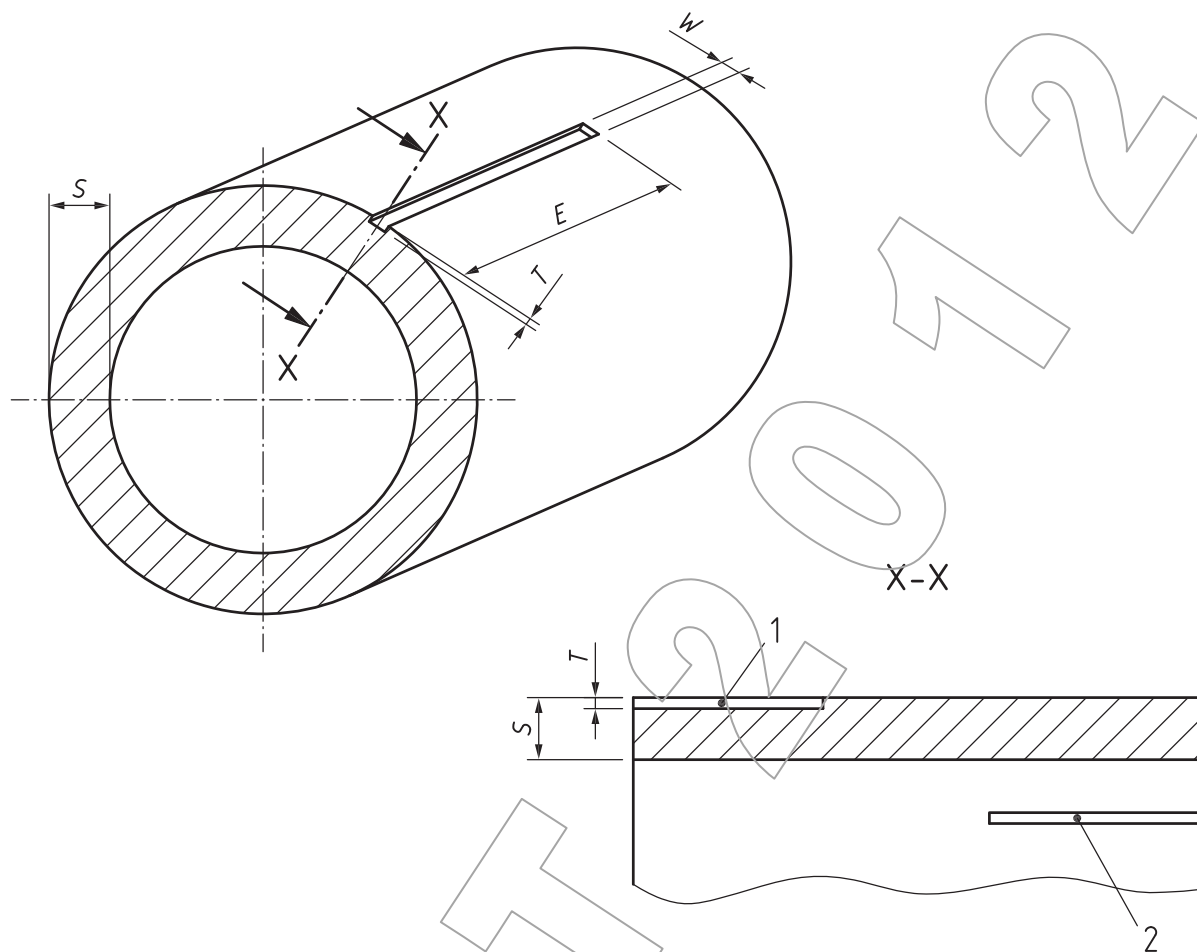

NOTE $T \leq (5 \pm 0,75) \% S$ but ≤ 1 mm and $\geq 0,2$ mm ; $W \leq 2T$, but if not possible then ≤ 1 mm ; $E \leq 50$ mm

Key

- 1 Outside reference notch
- 2 Inside reference notch
- E Notch length
- S Tube nominal wall thickness
- T Notch depth
- W Notch width

Figure C.1 — Design details and dimensions of the reference notches for longitudinal defects

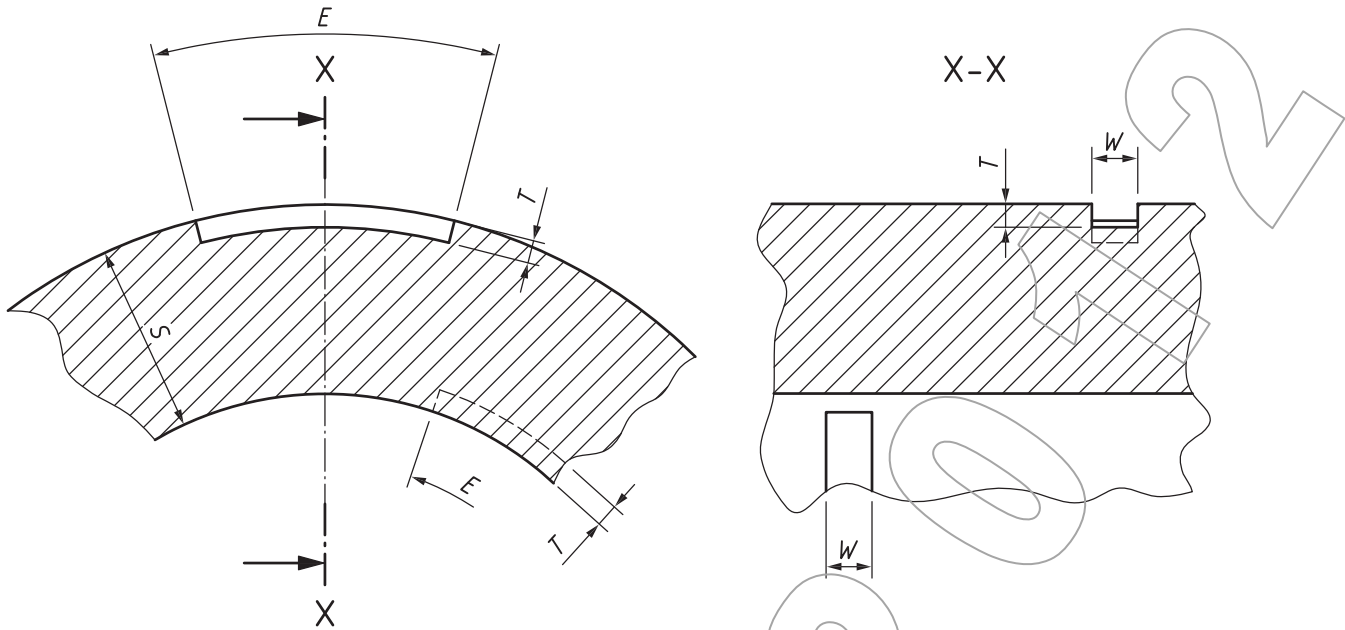

NOTE $T \leq (5 \pm 0,75) \% S$ but ≤ 1 mm and $\geq 0,2$ mm ; $W \leq 2T$, but if not possible then ≤ 1 mm ; $E \leq 50$ mm

Key

- E Notch length
- T Notch depth
- S Tube nominal wall thickness
- W Notch width

Figure C.2 — Schematic representation of the reference notches for circumferential defects

C.3.3 Calibration of equipment

Using the reference standard described in C.3.2, the equipment shall be adjusted to produce clearly identifiable indications from inner and outer reference notches. The amplitude of the indications shall be as near equal as possible. The indication of smallest amplitude shall be used as the rejection level and for setting visual, audible, recording or sorting devices. The equipment shall be calibrated with the reference standard or probe, or both, moving in the same manner, in the same direction and at the same speed as will be used during the inspection of the tube. All visual, audible, recording or sorting device shall operate satisfactorily at the test speed.

C.3.4 Wall thickness measurement

If the measurement of the wall thickness is not carried out at another stage of production, the cylindrical part shall be 100 % examined to ensure that the thickness is not less than the guaranteed minimum value.

C.3.5 Interpretation of results

Tubes with indications which are equal to or greater than the lowest of the indications from the reference notches shall be withdrawn. Surface defects shall be removed; after removal the tubes shall be re-subjected to ultrasonic flaw detection and thickness measurement.

Any tube which is shown to be below the guaranteed minimum wall thickness shall be rejected.

C.3.6 Certification

The ultrasonic testing shall be certified by the tube manufacturer.

Every tube, which has passed the ultrasonic testing in accordance with this specification shall be stamp marked with the symbol "UT".

Bibliography

ISO 11439, *Gas cylinders — High pressure cylinders for the on-board storage of natural gas as a fuel for automotive vehicles*

DRAFT 2012