

NEMA VE 1

METAL CABLE TRAY
SYSTEMS

NEMA Standards Publication VE 1-2009

Canadian Standards Association Publication CSA C22.2 No. 126.1-09

Metal Cable Tray Systems

Published by:

National Electrical Manufacturers Association

1300 North 17th Street
Rosslyn, Virginia 22209

www.nema.org

In Canada, published by:

Canadian Standards Association

5060 Spectrum Way, Suite 100
Mississauga, ON, Canada L4W 5N6

www.csa.ca

© Copyright 2009 by the National Electrical Manufacturers Association. All rights including translation into other languages, reserved under the Universal Copyright Convention, the Berne Convention for the Protection of Literary and Artistic Works, and the International and Pan American Copyright Conventions.

© Copyright 2009 ISBN 1-55324-497-4

Canadian Standards Association

All rights reserved. No part of this publication may be reproduced in any form whatsoever without the prior permission of the publisher.

Commitment for Amendments

This Standard is issued jointly by Canadian Standards Association (CSA) and the National Electrical Manufacturers Association (NEMA). Amendments to this Standard will be made only after processing according to the standards-writing procedures of CSA and NEMA.

NOTICE AND DISCLAIMER

The information in this publication was considered technically sound by the consensus of persons engaged in the development and approval of the document at the time it was developed. Consensus does not necessarily mean that there is unanimous agreement among every person participating in the development of this document.

The National Electrical Manufacturers Association (NEMA) standards and guideline publications, of which the document contained herein is one, are developed through a voluntary consensus standards development process. This process brings together volunteers and/or seeks out the views of persons who have an interest in the topic covered by this publication. While NEMA administers the process and establishes rules to promote fairness in the development of consensus, it does not write the document and it does not independently test, evaluate, or verify the accuracy or completeness of any information or the soundness of any judgments contained in its standards and guideline publications.

NEMA disclaims liability for any personal injury, property, or other damages of any nature whatsoever, whether special, indirect, consequential, or compensatory, directly or indirectly resulting from the publication, use of, application, or reliance on this document. NEMA disclaims and makes no guaranty or warranty, expressed or implied, as to the accuracy or completeness of any information published herein, and disclaims and makes no warranty that the information in this document will fulfill any of your particular purposes or needs. NEMA does not undertake to guarantee the performance of any individual manufacturer or seller's products or services by virtue of this standard or guide.

In publishing and making this document available, NEMA is not undertaking to render professional or other services for or on behalf of any person or entity, nor is NEMA undertaking to perform any duty owed by any person or entity to someone else. Anyone using this document should rely on his or her own independent judgment or, as appropriate, seek the advice of a competent professional in determining the exercise of reasonable care in any given circumstances. Information and other standards on the topic covered by this publication may be available from other sources, which the user may wish to consult for additional views or information not covered by this publication.

NEMA has no power, nor does it undertake to police or enforce compliance with the contents of this document. NEMA does not certify, test, or inspect products, designs, or installations for safety or health purposes. Any certification or other statement of compliance with any health or safety-related information in this document shall not be attributable to NEMA and is solely the responsibility of the certifier or maker of the statement.

CONTENTS

Preface	iii
Foreword (NEMA)	iv
Section 1 SCOPE	1
Section 2 DEFINITIONS AND ABBREVIATIONS	2
2.1 Definitions	2
2.2 Abbreviations	3
Section 3 GENERAL	4
3.1 Reference Publications	4
3.2 Units of Measurement	4
Section 4 CONSTRUCTION	5
4.1 Materials	5
4.2 Finishes	5
4.3 Typical Dimensions	6
4.3.1 General	6
4.3.2 Lengths of Straight Sections	6
4.3.3 Widths	6
4.3.4 Fill Depths	7
4.3.5 Nominal Rung Spacings on Straight Sections	7
4.3.6 Inside Radii	7
4.3.7 Degrees of Arc for Elbows	7
4.4 Quality of Work	8
4.5 Fittings	8
4.6 Fasteners	8
4.7 Bonding	8
4.8 Load Capacity	8
Section 5 TESTS	9
5.1 Electrical Continuity of Connections	9
5.2 Load Testing	9
5.2.1 General	9
5.2.2 Test Specimen	9
5.2.3 Type and Length of Span	9
5.2.4 Orientation of Specimen	9
5.2.5 Supports	9
5.2.6 Loading Material	10
5.2.7 Load Application	10
5.2.8 Loading to Destruction (Method A)	10
5.2.9 Loading to Residual Deflection (Method B)	11
5.3 Interpolation of Test Data—For Use with 5.2.8 (Method A) Only	11
5.4 Rung Load Capacity (Optional)	11
5.4.1 General	11
5.4.2 Test Equipment	12
5.4.3 Test Specimen	12
5.4.4 Span Length and Supports	12
5.4.5 Orientation of Specimens	12
5.4.6 Loading	12

5.4.7	Load Capacity.....	12
5.4.8	Interpolation of Rung Load Test Data.....	12
Section 6 PRODUCT MARKING, INFORMATION, AND INSTALLATION		13
6.1	Marking on Product	13
6.2	Product Information	13
6.3	Cable Tray Installation.....	13

Tables

Table 1	Span/Load Class Designation—USA.....	14
Table 2	Span/Load Class Designation—CANADA	14

Figures

Figure 1	Illustration of Selected Definitions	15
Figure 2	Application of Load—Rung Load Capacity	16

Annex (informative)

Annex A	Markings—French Translations	17
---------	------------------------------------	----

Preface

This is the common CSA and NEMA Standard for Metal Cable Tray Systems. It is the third edition of C22.2 No. 126.1, superseding the previous editions published in 2002 and 1998, and the fifth edition of NEMA VE 1, superseding the previous edition published in 2002.

This common Standard was prepared by the CANENA Technical Harmonization Committee for Metal Cable Tray Systems, comprising members from the Canadian Standards Association, National Electrical Manufacturers Association, and the cable tray manufacturing industry. The efforts of the CANENA Technical Harmonization Committee are gratefully acknowledged.

This standard is considered suitable for use for conformity assessment within the stated scope of the standard.

This Standard was reviewed by the CSA Subcommittee on Cable Tray Systems under the jurisdiction of the Technical Committee on Wiring Products and the Strategic Resource Group, and has been formally approved by the Technical Committee. Where reference is made to a specific number of samples to be tested, the specified number is considered to be a minimum quantity. This Standard was also approved at NEMA by the Codes and Standards Committee.

NOTE—Although the intended primary application of this Standard is stated in its Scope, it is important to note that it remains the responsibility of the users of the Standard to judge its suitability for their particular purpose.

Level of Harmonization

This Standard uses an IEC format, but is not based on, nor is it to be considered equivalent to, an IEC standard. This Standard is published as an equivalent standard.

An equivalent standard is a standard that is substantially the same in technical content, except as follows. Technical deviations are allowed for Codes and Governmental Regulations and those recognized as being in accordance with NAFTA Article 905, for example, because of fundamental, climatic, geographical, technological, or infrastructural factors, scientific justification, or the level of protection that the country considers appropriate. Presentation of the NEMA and CSA versions is to be word for word except for editorial changes.

Reasons for Differences to IEC

The Technical Harmonization Committee (THC) identified one IEC standard that addresses electrical cable tray systems included in the scope of this Standard. The THC determined the safe use of electrical cable tray is dependent on the design, performance, and installation of the cable tray system. The IEC standard does not mention the equipment grounding function of cable tray, and there are no requirements for corrosion protection at this time. Significant investigation is required to assess safety and system issues that may lead to harmonization of traditional North American electrical cable tray standards with those presently addressed in the known IEC standard. The THC agreed such future investigation might be facilitated by completion of harmonization of the North American standards for electrical cable tray.

Interpretations

The interpretation by the Standards Development Organization (SDO) of an identical or equivalent standard is to be based on the literal text to determine compliance with the standard in accordance with the procedural rules of the SDO. If more than one interpretation of the literal text has been identified, a revision is to be proposed as soon as possible to each of the SDOs to more accurately reflect the intent.

CSA Effective Date

The effective date for CSA will be announced through *CSA Informs* or a CSA Certification Notice.

NEMA Effective Date

The effective date for NEMA will be the publication date.

Foreword (NEMA)

This Standards Publication provides technical requirements concerning the construction, testing, and performance of metal cable tray systems. The development of this publication is the result of many years of research, investigation, and experience by the members of the Cable Tray Section of NEMA. Throughout the development of this publication, test methods and performance values have been related as closely as possible to end-use applications. It has been developed through consultation among manufacturers, with users and engineering societies, to result in improved serviceability and safety of metal cable tray systems.

This publication reflects the study of applicable building codes and the *National Electrical Code*[®], and adheres to applicable national material and manufacturing standards, such as those of the American Society for Testing and Materials, the American Iron and Steel Institute, the Aluminum Association, and Underwriters Laboratories, Inc. The NEMA Cable Tray Section periodically reviews this publication for any revisions necessary, to keep it up to date with advancing technology.

Comments or recommended revisions are welcomed and should be submitted to:

Vice President, Technical Services
National Electrical Manufacturers Association
1300 North 17th Street, Suite 1752
Rosslyn, Virginia 22209

The primary purpose of this Standards Publication is to encourage the manufacture and utilization of standardized metal cable tray systems and to eliminate misunderstandings between manufacturers and users.

The cable tray system manufacturer has limited or no control over the following factors, which are vital to a safe installation:

- a. environmental conditions;
- b. system design;
- c. product selection and application;
- d. installation practices; and
- e. system maintenance.

This Standards Publication was developed by the Cable Tray Section, and has been promulgated with a view toward promoting safety of persons and property by the proper selection and use of metal cable tray systems. At the time it was approved, the Cable Tray Section was composed of the following members:

Cablofil, Inc.—Mascoutah, IL
Chalfant Manufacturing Company—Cleveland, OH
Cooper B-Line—Highland, IL
Cope/Allied Electrical Group—Harvey, IL
MP Husky Corporation—Greenville, SC
P-W Industries, Inc.—Atlanta, GA
The Wiremold Company—West Hartford, CT
Thomas & Betts Corporation—Memphis, TN

Section 1

SCOPE

This Standard specifies the requirements for metal cable trays and associated fittings designed for use in accordance with the rules of the *Canadian Electrical Code (CEC), Part I*, and the *National Electrical Code (NEC)*.

Section 2 DEFINITIONS AND ABBREVIATIONS

2.1 DEFINITIONS

The following definitions apply in this Standard (see also Figure 1):

accessory: Components used to supplement the function of a straight section or fitting. Examples include, but are not limited to, dropout, cover, conduit adapter, hold-down device, and divider.

cable tray support span: The distance between the centerlines of supports.

cable tray system: A section or assembly of sections, and associated fittings, forming a mechanical system used to support cables and raceways.

channel cable tray: A fabricated structure consisting of a one-piece ventilated-bottom or solid-bottom channel section.

connector: A component that joins any combination of cable tray straight sections and fittings. The basic types of connectors include rigid, expansion, adjustable, and reducer.

fasteners: Screws, nuts, bolts, washers, rivets, spacers, pins, and other items used to connect and assemble cable tray systems.

fill depth: The vertical interior dimension of a cable tray that is used to calculate the allowable interior cross-sectional area.

fitting: A component that is used to change the size or direction of a cable tray system.

horizontal cross: A fitting that joins cable trays in four directions at 90° intervals in the same plane.

horizontal elbow: A fitting that changes the direction of cable tray in the same plane.

horizontal tee: A fitting that joins cable trays in three directions at 90° intervals in the same plane.

horizontal wye: A fitting that joins cable trays in three directions at other than 90° intervals in the same plane.

ladder cable tray: A fabricated structure consisting of two longitudinal side rails connected by individual transverse members (rungs).

reducer: A fitting that joins cable trays of different widths in the same plane.

left-hand reducer: A reducer having, when viewed from the large end, a straight side on the left.

right-hand reducer: A reducer having, when viewed from the large end, a straight side on the right.

straight reducer: A reducer having two symmetrical offset sides.

single-rail cable tray: A fabricated structure consisting of a longitudinal rail with transversely connected members (rungs) that project from one side (side-supported) or both sides (center-supported), which may be single- or multi-tier.

solid-bottom or nonventilated cable tray: A fabricated structure consisting of a bottom without ventilation openings within integral or separate longitudinal side rails.

straight section: A length of cable tray that has no change in direction or size.

support: A component that provides a means for supporting a cable tray, including, but not limited to, cantilever bracket, trapeze, and individual rod suspension.

trough or ventilated cable tray: A fabricated structure consisting of integral or separate longitudinal rails and a bottom having openings sufficient for the passage of air and utilizing 75% or less of the plan area of the surface to support cables where the maximum open spacings between cable support surfaces of transverse elements do not exceed 100 mm (4 in.) in the direction parallel to the tray side rails.

NOTES—

- (1) On horizontal bends only, the maximum distance between transverse elements is measured at the centerline of the bend.
- (2) A ladder cable tray having rung spacing such that the cable tray meets the definition described above is considered to be a ventilated cable tray.

vertical elbow: A fitting that changes the direction of cable tray to a different plane.

inside vertical elbow: A fitting that changes the direction of cable tray upward from the horizontal plane.

outside vertical elbow: A fitting that changes the direction of cable tray downward from the horizontal plane.

vertical tee: A fitting that joins cable trays in three directions at 90° intervals in different planes.

wire mesh cable tray: A manufactured wire mesh tray consisting of steel wires welded at all intersections. Longitudinal wires located on the exterior of the tray are spaced at a maximum of 50 mm (2 in.) and transverse wires are spaced at a maximum of 100 mm (4 in.).

wire mesh cable tray fitting: A fitting for wire mesh cable tray systems, fabricated from wire mesh cable tray straight sections. The fitting is field-constructed and attached to the adjacent sections using splice connectors in accordance with the manufacturer's instructions.

2.2 ABBREVIATIONS

The following abbreviations apply in this standard:

A — ampere
ac — alternating current
°C — degrees Celsius
dc — direct current
°F — degrees Fahrenheit
ft — foot
in. — inch
kg — kilogram
lb — pound
lin ft — linear foot
lin m — linear meter
m — meter
min — minute
mm — millimeter
Ω — ohm
SI — International System of Units (metric)

Section 3 GENERAL

3.1 REFERENCE PUBLICATIONS

Where reference is made to other publications, such reference shall be considered to refer to the latest edition and all amendments published to that edition up to the time when this Standard was approved.

Canadian Standards Association (CSA)
5060 Spectrum Way, Suite 100
Mississauga, ON, Canada L4W 5N6

C22.1-09 *Canadian Electrical Code, Part I*

National Electrical Manufacturers Association (NEMA)
1300 North 17th Street, Suite 1752
Rosslyn, Virginia 22209

VE 2-2006 *Cable Tray Installation Guidelines*

American National Standards Institute (ANSI)
11 West 42nd Street
New York, NY 10036

ANSI/NFPA 70-2008 *National Electrical Code*

American Society for Testing and Materials (ASTM)
1916 Race Street
Philadelphia, PA 19103

A 123/A 123M-02 *Standard Specification for Zinc (Hot-Dip Galvanized) Coatings on Iron and Steel Products*

A 653/A 653M-06 *Standard Specification for Steel Sheet, Zinc-Coated (Galvanized) or Zinc-Iron Alloy-Coated (Galvannealed) by the Hot-Dip Process*

B 633-07 *Standard Specification for Electrodeposited Coatings of Zinc on Iron and Steel*

3.2 UNITS OF MEASUREMENT

The values given in SI (metric) units are mandatory. Any other values given are for information only.

NOTE—Lengths are shown in millimeters or meters (inches or feet). Widths, deflections, and similar measurements are generally defined in millimeters (fractions of inches), and load-bearing capacity in kilograms/meter (pounds/foot).

Section 4 CONSTRUCTION

4.1 MATERIALS

Cable tray systems shall be made of either corrosion-resistant metal, such as aluminum or stainless steel, or metal with a corrosion-resistant finish.

4.2 FINISHES

4.2.1 Carbon steel used for cable trays shall be protected against corrosion by one of the following processes:

(a) Type 1—Hot-dip galvanizing after fabrication in accordance with ASTM A 123/A 123M;

NOTE—Fabricated products that are hot-dip galvanized are thoroughly cleaned, fluxed, and immersed in a bath of molten zinc, where they react to form a metallurgically bonded zinc coating. Normal oxidation of the galvanized surfaces will, in a short period of time, appear as a dull gray or white coating. Some degree of roughness and variations of thicknesses can be expected as a result of the hot-dipping process. Because the galvanizing process takes place at the low end of the stress-relieving temperature range, some stress relief occurs, and some distortion or warping may result.

(b) Type 2—Hot-dip mill galvanizing in accordance with ASTM A 653/A 653M, coating designation G90;

NOTE—Hot-dip mill galvanized coatings are produced by continuously rolling steel sheets or strips in coils through a bath of molten zinc. The process involves pretreating the steel to make the surface react readily with molten zinc as the strip moves through the bath at high speeds. During fabrication, where slitting, forming, cutting, or welding is performed, the cut edges and heat-affected zone of welding are subject to superficial oxidation. These areas are then protected through electrolytic action of the adjacent zinc surfaces. The coating is smooth, ductile, and adherent.

NOTE—For corrosive or wet locations, other coatings may be more suitable.

(c) Type 3—Electrodeposited zinc in accordance with ASTM B 633 (SC 2 minimum); or

NOTE—Fabricated products that are to receive electrodeposited zinc (zinc plated) coatings are thoroughly cleaned and then a thin layer of zinc is deposited by electrolysis. A conversion coating can then be applied to the zinc surface, resulting in a colored (typically yellow) or colorless (clear-blue) appearance. Electrodeposited zinc is a common indoor finish for wire mesh cable trays. For corrosive or wet locations, other coatings or materials may be more suitable.

(d) Other coatings as appropriate for the application. Where a nationally recognized standard exists, the coating shall be applied in accordance with that standard.

4.2.2 For installations in highly corrosive environments, such as alkaline or acidic conditions, different or additional protective coatings may be provided, as agreed to between the end user and the manufacturer.

4.2.3 Carbon steel nuts and bolts shall be protected against corrosion by one of the following processes:

(a) Zinc electroplating in accordance with ASTM B 633; or

(b) other coatings as appropriate for the application. Where a nationally recognized standard exists, the coating shall be applied in accordance with that standard.

4.3 TYPICAL DIMENSIONS

4.3.1 General

Clauses 4.3.2 to 4.3.7 provide the typical dimensions used in the industry. Other dimensions shall also be acceptable. Dimensions are based on rationalized conversions.

4.3.2 Lengths of Straight Sections

Typical lengths, not including connectors, are:

- (a) 3 m \pm 5 mm (10 ft \pm 3/16 in.);
- (b) 3.66 m \pm 5 mm (12 ft \pm 3/16 in.);
- (c) 6 m \pm 9 mm (20 ft \pm 5/16 in.); and
- (d) 7.32 m \pm 9 mm (24 ft \pm 5/16 in.).

4.3.3 Widths

4.3.3.1 For sections other than channel cable trays or wire mesh cable trays, typical widths are:

- (a) 150 mm (6 in.);
- (b) 225 mm (9 in.);
- (c) 300 mm (12 in.);
- (d) 450 mm (18 in.);
- (e) 600 mm (24 in.);
- (f) 750 mm (30 in.); and
- (g) 900 mm (36 in.).

NOTE—The tolerance of the widths is within \pm 6 mm (1/4 in.) for inside dimensions.

Overall width shall not exceed the inside width by more than 100 mm (4 in.).

4.3.3.2 For channel cable trays, typical widths are:

- (a) 75 mm (3 in.);
- (b) 100 mm (4 in.); and
- (c) 150 mm (6 in.).

NOTE—The tolerance of the widths is within \pm 6 mm (1/4 in.) for inside dimensions.

4.3.3.3 For wire mesh cable trays, typical widths are:

- (a) 50 mm (2 in.);
- (b) 100 mm (4 in.);
- (c) 150 mm (6 in.);
- (d) 200 mm (8 in.);
- (e) 300 mm (12 in.);
- (f) 400 mm (16 in.);
- (g) 450 mm (18 in.);
- (h) 500 mm (20 in.); and
- (i) 600 mm (24 in.).

NOTE—The tolerance of the widths is within \pm 3 mm (1/8 in.) for inside dimensions.

4.3.4 Fill Depths

4.3.4.1 For other than channel cable trays or wire mesh cable trays, typical depths for sections are:

- (a) 75 mm (3 in.);
- (b) 100 mm (4 in.);
- (c) 125 mm (5 in.); and
- (d) 150 mm (6 in.).

NOTE—The tolerance of the depths is within ± 10 mm (3/8 in.).

Outside depths shall not exceed inside depths by more than 30 mm (1-1/4 in.).

4.3.4.2 For channel cable trays, typical depths are 30–50 mm (1-1/4–2 in.) for outside dimensions.

4.3.4.3 For wire mesh cable trays, typical depths are:

- (a) 25 mm (1 in.);
- (b) 50 mm (2 in.);
- (c) 100 mm (4 in.); and
- (d) 150 mm (6 in.).

NOTE—The tolerance of the depths is within ± 10 mm (3/8 in.).

Outside depths shall not exceed inside depths by more than 30 mm (1-1/4 in.).

4.3.4.4 For single-rail cable trays, typical depths are:

- (a) 75 mm (3 in.);
- (b) 100 mm (4 in.);
- (c) 125 mm (5 in.); and
- (d) 150 mm (6 in.).

NOTE—The tolerance of the depths is within ± 10 mm (3/8 in.).

4.3.5 Nominal Rung Spacings on Straight Sections

Typical rung spacings are:

- (a) 150 mm (6 in.);
- (b) 225 mm (9 in.); and
- (c) 300 mm (12 in.).

4.3.6 Inside Radii

Typical inside radii of curved sections are:

- (a) 300 mm (12 in.);
- (b) 600 mm (24 in.); and
- (c) 900 mm (36 in.).

4.3.7 Degrees of Arc for Elbows

Typical degrees of arc for elbow sections are:

- (a) 30°;
- (b) 45°;
- (c) 60°; and
- (d) 90°.

4.4 QUALITY OF WORK

Cable tray systems shall be free from burrs or other sharp projections that could cause damage to the cable jacket during installation.

4.5 FITTINGS

Fittings shall not be required to be subjected to the load test described in Clause 5.2.

NOTE—Since fittings are not load-tested, they will not meet the strength requirements of straight sections unless supported as shown in NEMA VE 2, or in accordance with the manufacturer's instructions.

4.6 FASTENERS

Fasteners used for connection and assembly of a cable tray system shall be supplied according to the manufacturer's instructions and shall comply with the requirements of Clause 4.2.3.

4.7 BONDING

4.7.1 Cable tray systems shall be provided with connection means meeting the requirements of Clause 5.1.

4.7.2 Where paint or additional coatings are applied to components of the cable tray system, means shall be provided to ensure a measured resistance in accordance with Clause 5.1.

4.8 LOAD CAPACITY

4.8.1 Straight sections of cable tray shall meet the requirements of the test specified in Clause 5.2. See also Clause 5.3.

NOTES—

(1) The load ratings in Table 1 and Table 2 are those most commonly used.

(2) See Clause 5.3 for interpolation of test data when determining the load rating of spans shorter than the tested span.

4.8.2 A concentrated static load is not included in Table 1 and Table 2. Some user applications may require that a given concentrated static load be imposed over and above the working load. Depending on concentrated load value and location of load, some cable tray systems may not be suitable for support. When considering a concentrated load applied other than described below, consult the manufacturer.

A concentrated static load represents a static weight applied on the centerline of the tray at midspan. When so specified, the concentrated static load may be converted to an equivalent uniform load (W_e) in kg/lin m (lb/lin ft), using the following formula, and added to the static weight of cables in the tray:

$$W_e = \frac{2 \times (\text{concentrated static load, kg (lb)})}{\text{span length, m (ft)}}$$

4.8.3 Channel cable tray straight sections not exceeding 150 mm (6 in.) in width and 50 mm (2 in.) in depth need not be load-tested in accordance with Clause 5.2.

Section 5 TESTS

5.1 ELECTRICAL CONTINUITY OF CONNECTIONS

5.1.1 Each specimen shall consist of two 600 mm (24 in.) minimum lengths of standard spliced or coupled sections.

5.1.2 A current of 30 A dc shall be passed through the specimen and the resistance measured between two points located 1.6 mm (1/16 in.) from each side of the splice or coupling. The net resistance of the connection shall be not more than 0.00033 Ω as computed from the measured voltage drop and current passing through the specimen, at an ambient temperature of 15–35°C (60–95°F). The current source shall be applied at least 300 mm (12 in.) on either side of the splice or coupling.

5.2 LOAD TESTING

5.2.1 General

Cable tray specimens shall be subjected to either loading to destruction (Method A), as specified in Clause 5.2.8, or loading to residual deflection (Method B), as specified in Clause 5.2.9. For wire mesh trays, only Method A shall be used.

5.2.2 Test Specimen

For each design of cable tray, two specimens shall be tested. An unspliced straight section of the greatest width shall be used in each test.

For trays with rungs, rung spacings shall be the largest in a particular class.

Differences in gauge, wire diameter, height of rail(s), rung design, rung spacing greater than the tested spacings, bottom to rail connection, or in the configuration of any part shall constitute a different design.

Coated trays need not be tested, provided that bare or pregalvanized trays of the same class have been tested.

5.2.3 Type and Length of Span

The test specimen shall be a simple beam span, with free unrestrained ends. Trays shall not have side restraints. Span lengths shall be as specified, with a tolerance of ± 38 mm (1-1/2 in.).

Side-mounted single-rail cable trays shall have restrained ends.

5.2.4 Orientation of Specimen

Specimens shall be tested in the horizontal position. The total length of the test specimen shall be not more than the specified span length + 20%. Any overhang shall be equally distributed beyond both supports.

5.2.5 Supports

Each end of the specimen shall be supported by a steel bar(s) of 30 mm (1-1/8 in.) width and 19 mm (3/4 in.) height, with a 120° V-notch cut in its bottom to a depth of 5 mm (3/16 in.). The V-notch shall rest on a 25 mm (1 in.) solid round steel bar fastened to a rigid base, or the specimen shall be supported directly on a 65 mm (2-1/2 in.) diameter round steel bar or heavy wall steel tube fastened to a rigid base.

At the supports, single-rail trays may have side restraints that do not constrain vertical movement.

Side-mounted single-rail cable tray specimens shall be supported to the wall as recommended by the manufacturer at both ends and at mid-point.

5.2.6 Loading Material

Loading material shall be steel strips, lead ingots, or other loading materials meeting the following requirements:

- (a) Individual steel strips shall have rounded or deburred edges, a maximum thickness of 3 mm (1/8 in.), a maximum width of 100 mm (4 in.), and a maximum length of 7.32 m (24 ft).

When load testing wire mesh cable tray with strips having a thickness of 3 mm (1/8 in.) and a maximum width of 100 mm (4 in.), the length of the strips shall not exceed 50% of the length of the test span. When full span strips are used, the maximum thickness shall be 1.6 mm (1/16 in.), and the maximum width shall be 100 mm (4 in.).

- (b) Five lead ingots, each weighing approximately 2.3 kg (5 lb), shall be interconnected across corners into a string of five ingots approximately 550 mm (22 in.) long. Individual ingots shall be hexagonal, approximately 75 mm (3 in.) in diameter, and 38 mm (1-1/2 in.) deep.
- (c) Other loading materials shall have a maximum weight of 4.5 kg (10 lb), a maximum width of 125 mm (5 in.), and a maximum length of 300 mm (12 in.).

5.2.7 Load Application

5.2.7.1 The load shall be applied in at least 10 increments that are approximately equal in weight.

5.2.7.2 Loading shall be uniformly distributed for the length and breadth of the specimen, except that the loading material shall not be closer than 13 mm (1/2 in.) nor further than 25 mm (1 in.) from the innermost elements of the sides. It shall be arranged across the tray with a minimum of 10 mm (3/8 in.) between stacks so that the loading material does not bridge transversely. All loading materials shall be placed between supports without overhanging. In multi-tier cable trays, the loading shall be uniformly distributed among the tiers.

5.2.7.3 For loading weight in trays with rungs, the bottom of the tray between supports may be covered with a flat sheet of No. 9 gauge, flattened expanded material not more than 900 mm (3 ft) long and with a wire hole size of 19 mm (3/4 in.), or a flat sheet of No. 16 gauge sheet steel not more than 900 mm (3 ft) long. The expanded metal or sheet steel (dunnage) shall not be fastened to the tray and shall be no closer than 13 mm (1/2 in.) to the side rails. The lengths shall not overlap by more than 50 mm (2 in.). The weight of expanded metal or sheet steel shall be added to the total weight of the loading material.

5.2.8 Loading to Destruction (Method A)

The total weight of the loading material on the cable tray, plus dunnage if used, prior to addition of the incremental weight that causes the destruction, shall be considered to be the destruction load. The rated load capacity of the cable tray shall be the destruction load divided by a safety factor of 1.5. For multi-tier trays, failure of any of the tiers shall be considered as failure of the whole cable tray.

The deflection shall be recorded for each additional incremental load. The maximum deflection reading shall be recorded for the rated load.

5.2.9 Loading to Residual Deflection (Method B)

5.2.9.1 Minimum Test Load

The minimum test load to be applied shall be determined in accordance with the following formula:

$$\text{Total minimum test load} = 1.5 \times L \times w$$

Where:

- 1.5 = safety factor
- L = span length, m (ft)
- w = rated load, kg/m (lb/ft)

5.2.9.2 Load Application

Each specimen shall first be loaded to 10% of the minimum test load. The vertical deflection of the tray shall be measured at three points along the line midway between the supports and at right angles to the longitudinal axis of the tray. The three points of measurement shall be under each side rail and at the center of the tray. In trays where there are no side rails, the three points of measurement shall be under the outer edges and under the center. This measurement shall be known as the initial deflection. The loading shall then be continued until all of the rated load is applied. The deflection shall be measured in the same manner as the initial deflection. The loading shall then be continued until the total minimum test load has been applied. The total load shall then be removed from the tray. After 15 min, the vertical deflection shall be measured in the same manner as previously used. This measurement shall be known as the residual deflection. The specimen may then be reloaded until it collapses, and the values of the load at collapse shall be recorded. This information concerning the load at collapse point is optional, but some users may require it to obtain product acceptance.

5.2.9.3 Measurement of Residual Deflection

The residual deflection at each point of measurement of the two specimens shall be averaged. Where a residual deflection for either specimen is equal to or exceeds 80% of the initial deflection and, in addition, deviates from the average by more than 10%, two more specimens shall be tested. The average of the three highest values at the point of measurement of the four specimens shall be regarded as the final result.

In multi-tier trays, the maximum deflection in any of the tiers shall be considered the maximum deflection of the whole tray.

5.3 INTERPOLATION OF TEST DATA—FOR USE WITH 5.2.8 (METHOD A) ONLY

When allowable load and deflection data are determined by the load test, destruction load capacity for span lengths less than the tested span shall be interpolated with the formula shown below. When interpolating in this manner, ensure that the rung strength is also sufficient to support the load.

$$w_2 = w_1 \times L_1^2 / L_2^2$$

Where:

- w_2 = calculated load, kg/m (lb/ft)
- w_1 = tested load, kg/m (lb/ft)
- L_1 = tested span length, m (ft)
- L_2 = new span length, m (ft)

5.4 RUNG LOAD CAPACITY (OPTIONAL)

5.4.1 General

If rung load capacity is to be specified by the manufacturer, the capacity shall be determined in accordance with Clauses 5.4.2 to 5.4.8.

5.4.2 Test Equipment

All load-bearing surfaces shall be flat, with edges rounded to a maximum radius of 3.2 mm (1/8 in.). An example of the application of the load is shown in Figure 2.

5.4.3 Test Specimen

For each rung design, two separate tests of the greatest rung length shall be made.

5.4.4 Span Length and Supports

Test spans shall be simple beam spans with free, unrestrained ends. Rungs shall not have side restraints. Each end of the specimen shall be supported by a flat steel bar at a span length as specified ± 38 mm (1-1/2 in.).

5.4.5 Orientation of Specimens

Specimens shall be tested in the horizontal position. The total length of the test specimen shall be the specified span length + 150 mm (6 in.) maximum. Any overhang shall be equally distributed beyond both supports.

5.4.6 Loading

All specimens shall be loaded to destruction. The loading shall be a concentrated load, applied to the 25 mm (1 in.) central length of the span.

5.4.7 Load Capacity

The maximum load applied to the rung shall be considered the destruction load capacity of the rung. The rated load capacity shall be the destruction load divided by a safety factor of 1.5.

NOTE—The rated load may be expressed as a uniform load by multiplying the concentrated load by a factor of two.

5.4.8 Interpolation of Rung Load Test Data

When the rated load data are determined by Clause 5.4.7, the rated load capacity for span lengths less than the tested span shall be interpolated with the following formula:

$$w_2 = w_1 \times L_1^2 / L_2^2$$

Where:

- w_2 = calculated load, kg/m (lb/ft)
- w_1 = tested load, kg/m (lb/ft)
- L_1 = tested span length, m (ft)
- L_2 = new span length, m (ft)

Section 6 PRODUCT MARKING, INFORMATION, AND INSTALLATION

NOTE—In Canada, there are two official languages, English and French. Annex A lists French translations of the markings specified in this Standard.

6.1 MARKING ON PRODUCT

6.1.1 Dimensions and measurements marked on the product shall include SI units. Markings expressed in inch-pound units shall be optional.

6.1.2 Each straight section of cable tray and each fitting shall be marked in a permanent and readily visible manner with the following:

- (a) the manufacturer's name, trademark, or other recognized symbol of identification;
- (b) the word "Ventilated" or "Nonventilated," as applicable;
- (c) the rated load/span as tested in accordance with Clause 5.2. Load classes as referenced in Table 1 and Table 2 may be marked in addition to, but not in place of, the rated load/span;
- (d) type of material, such as stainless steel (including the type), aluminum, etc; and, if carbon steel, Type 1 (hot-dip galvanized), Type 2 (mill galvanized), or Type 3 (electrodeposited zinc), as applicable. If the manufacturer's catalogue number marked on the product would readily lead the user to the required information published by the manufacturer, this marking is not mandatory;
- (e) when steel or aluminum cable tray systems are used as equipment grounding (or bonding) conductors, cable tray sections and fittings shall be marked to show the minimum cross-sectional area in accordance with the *CEC, Part I*, and the *NEC*; and
- (f) warning label that reads, "WARNING! DO NOT USE AS A WALKWAY, LADDER, OR SUPPORT FOR PERSONNEL. USE ONLY AS A MECHANICAL SUPPORT FOR CABLES, TUBING, AND RACEWAYS."

6.2 PRODUCT INFORMATION

The manufacturer shall provide, in a readily available form or with each shipment of cable tray, product information that shall include the following:

- (a) table or chart clearly indicating the maximum rated simple beam loading in kilograms/linear meter and/or pounds/linear foot, and the maximum recommended distance in meters and/or feet between supports for each loading; and
- (b) information on the alloys of aluminum or stainless steel, if such alloys are used.

6.3 CABLE TRAY INSTALLATION

Cable tray shall be installed in accordance with NEMA VE 2 or as recommended by the manufacturer.

Table 1
SPAN/LOAD CLASS DESIGNATION—USA
(See Clauses 4.8.1, 4.8.2 and 6.1.2 (c).)

Load, kg/m (lb/ft)	Span, m (ft)				
	1.5 (5)	2.4 (8)	3.0 (10)	3.7 (12)	6.0 (20)
37 (25)	5AA	8AA	10AA	12AA	20AA
74 (50)	5A	8A	10A	12A	20A
112 (75)	-	8B	-	12B	20B
149 (100)	-	8C	-	12C	20C

Note: These ratings are also used in Mexico

Table 2
SPAN/LOAD CLASS DESIGNATION—CANADA
See Clauses 4.8.1, 4.8.2 and 6.1.2(c)

Load kg/m (lb/ft)	Span, m (ft)						
	1.5 (5)	2.0	2.5	3.0 (10)	4.0	5.0	6.0 (20)
37 (25)				A			
45 (30)			A				
62 (42)		A					
67 (45)							D
82 (55)						D	
97 (65)				C			
99 (67)	A						
112 (75)							E
113 (76)					D		
119 (80)			C				
137 (92)						E	
164 (110)		C					
179 (120)				D			
189 (127)					E		
259 (174)	C						
299 (200)				E			

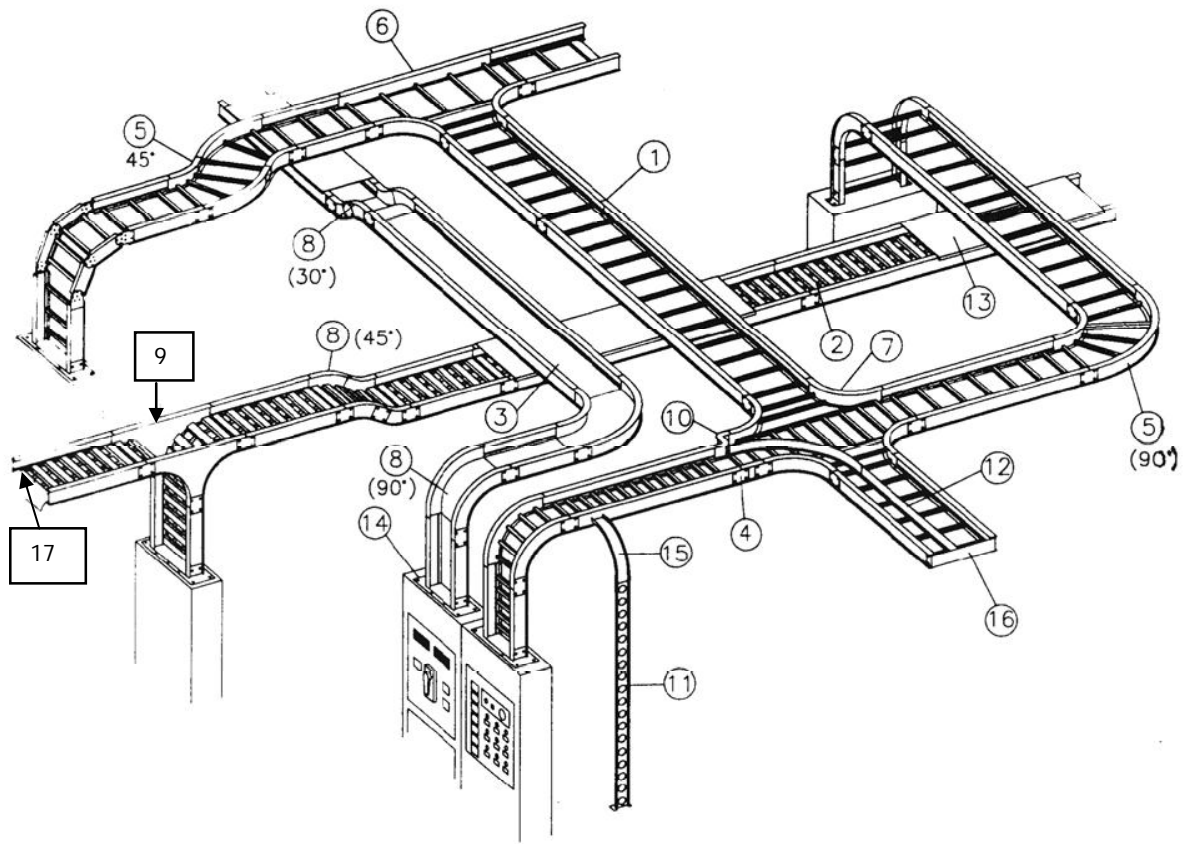

Legend:

- | | |
|-----------------------------|-----------------------------|
| 1 = Ladder cable tray | 10 = Reducer |
| 2 = Ventilated cable tray | 11 = Channel cable tray |
| 3 = Solid-bottom cable tray | 12 = Divider |
| 4 = Rigid connector | 13 = Cover |
| 5 = Horizontal elbow | 14 = Tray-to-box connector |
| 6 = Horizontal tee | 15 = Channel vertical elbow |
| 7 = Horizontal cross | 16 = Blind end |
| 8 = Vertical elbow | 17 = Dropout |
| 9 = Vertical tee | |

Figure 1
ILLUSTRATION OF SELECTED DEFINITIONS
(See Clause 2.1)

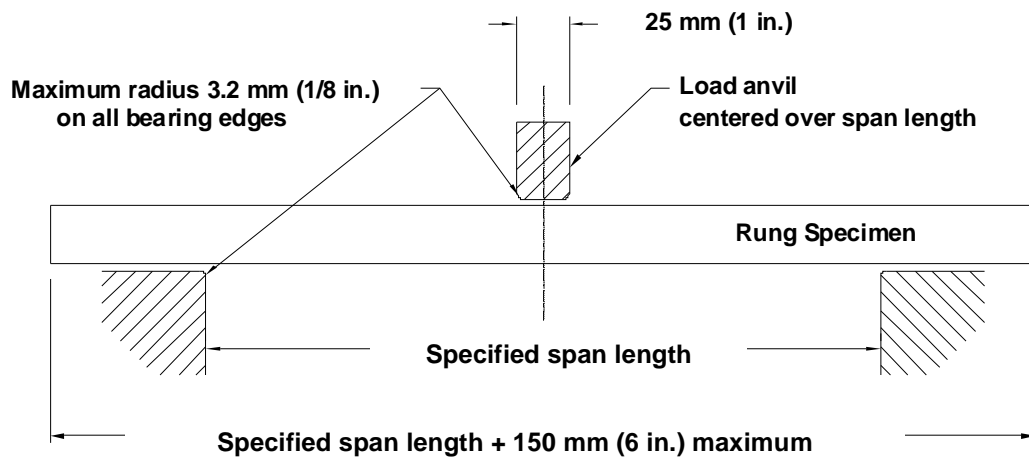

Figure 2
APPLICATION OF LOAD—RUNG LOAD CAPACITY
(See Clause 5.4.2.)

Annex A
MARKINGS—FRENCH TRANSLATIONS
(informative)

NOTE—This Annex is not a mandatory part of this Standard.

The following are acceptable French translations of required markings (see Clause 6):

Clause	English	French
6.1.2 (b)	Ventilated	Ajourés
6.1.2 (b)	Nonventilated	Non ajourés
6.1.2 (f)	WARNING! DO NOT USE AS A WALKWAY, LADDER, OR SUPPORT FOR PERSONNEL. USE ONLY AS A MECHANICAL SUPPORT FOR CABLES, TUBING, AND RACEWAYS.	AVERTISSEMENT! CECI N'EST PAS UNE PASSERELLE, NI UNE ÉCHELLE, NI UNE APPUI POUR LE PERSONNEL. UTILISER UNIQUEMENT POUR SUPPORTER DES CÂBLES, DES TUBES ET DES CANALISATIONS.

§